



Scan to know more



Corporate Office

SG Centre, 37C, Block A, Sector 132, Noida, Uttar Pradesh 201304, India
T : +91-120 6918000 F : +91-120 4041444

Stay connected. Stay updated.

[f](#) [in](#) [x](#) [yt](#) / APL APOLLO | [ig](#) / APL APOLLO OFFICIAL | TOLL FREE: 1800-102-3737

info@aplapollo.com | www.aplapollo.com

INDIA'S
No. 1
STRUCTURAL STEEL TUBE COMPANY



THE BIGGEST REVOLUTION FOR SUPER-FAST SHEDS

WITH APL APOLLO'S **1000 X 1000 MM** BOX SECTIONS, SHEDS CAN NOW BE CONSTRUCTED EASIER & FASTER THAN EVER BEFORE

INDUSTRIAL | WAREHOUSE | COLD STORAGE | HANGERS



*India's No. 1 by Market Share



THE BIG JUST GOT
**BIGGER &
STRONGER**



INTRODUCING INDIA'S FIRST 1000MM X 1000MM BOX SECTION



FASTER
CONSTRUCTION



REDUCED COST



IMPROVED
QUALITY



ECO-FRIENDLY



RESISTANCE TO
SEISMIC LOADING

APPLICATIONS:



HIGH-RISE BUILDINGS



HOSPITALS



AIRPORTS



RAILWAY STATION

THICKNESS: UPTO 40MM

THE GAME CHANGER

TO CHANGE THE NATION'S SKYLINE IS HERE

500mm X 500mm Box Section



SPEED
8 DAYS SLAB



COST
LOW PROJECT COST



QUALITY
PRE MANUFACTURED
STRUCTURE



ENVIRONMENT
NO DUST, NO POLLUTION,
& LOW GROUND WATER
CONSUMPTION

Suitable For:

High Rise Buildings, Hospitals, Housing, Schools, Hotels/Malls/Offices, Warehouses/Cold Storage, Factory Buildings, and Data Centres.





INDEX

ABOUT SG	02	
ABOUT APL APOLLO	02	
DESIGN - 1 5 meter span Bay spacing - 6.0 meter	03	Design - 1 (a) wind speed 39m/s Design - 1 (b) wind speed 47m/s Design - 1 (c) wind speed 55m/s
DESIGN - 2 10 meter span Bay spacing - 6.0 meter	05	Design - 2 (a) wind speed 39m/s Design - 2 (b) wind speed 47m/s Design - 2 (c) wind speed 55m/s
DESIGN - 3 10 meter span Bay spacing - 6.0 meter	07	Design - 3 (a) wind speed 39m/s Design - 3 (b) wind speed 47m/s Design - 3 (c) wind speed 55m/s
DESIGN - 4 15 meter span Bay spacing - 6.0 meter	09	Design - 4 (a) wind speed 39m/s Design - 4 (b) wind speed 47m/s Design - 4 (c) wind speed 55m/s
DESIGN - 5 20 meter span Bay spacing - 6.0 meter	11	Design - 5 (a) wind speed 39m/s Design - 5 (b) wind speed 47m/s Design - 5 (c) wind speed 55m/s
DESIGN - 6 25 meter span Bay spacing - 6.0 meter	13	Design - 6 (a) wind speed 39m/s Design - 6 (b) wind speed 47m/s Design - 6 (c) wind speed 55m/s
DESIGN - 7 30 meter span Bay spacing - 6.0 meter	17	Design - 7 (a) wind speed 39m/s Design - 7 (b) wind speed 47m/s Design - 7 (c) wind speed 55m/s
DESIGN - 8 30 meter span Bay spacing - 6.0 meter	21	Design - 8 (a) wind speed 39m/s Design - 8 (b) wind speed 47m/s Design - 8 (c) wind speed 55m/s
DESIGN - 9 25 meter span Bay spacing - 6.0 meter	25	Design - 9 (a) wind speed 39m/s Design - 9 (b) wind speed 47m/s Design - 9 (c) wind speed 55m/s
DESIGN - 10 30 meter span Bay spacing - 6.0 meter	27	Design - 10 (a) wind speed 39m/s Design - 10 (b) wind speed 47m/s Design - 10 (c) wind speed 55m/s
TYPICAL CONNECTION DETAIL	29	
PURLINS, GIRTS, TIE & BRACING MEMBERS DETAILS	33	
COMPLETED TUBULAR SHEDS RAIPUR DUJANA KASHMIR SATNA MEGHALAYA RAIPUR	35	



Sudesh Group

Sudesh Group is India's leading Steel Tubes and PVC Pipes manufacturer with 14 plants across different locations in the country. It's a pioneer in steel tubes of different types and shapes. For over 3 decades, SG Group has been revolutionizing the Steel Tubes manufacturing industry.



APL Apollo, a part of SG Group, is the country's largest manufacturer of steel pipes and tubes. Using High Frequency Induction Welding Technique (HFIW), APL Apollo has a capacity to produce 3.6 million tonnes of pipes per annum. The company is the unrivalled pioneer of Direct Forming Technology (DFT) as well as many other innovative products in the country.

DESIGN - 01

5 METER . SPAN | BAY SPACING - 6.0 METER
SLOPE - 1:10

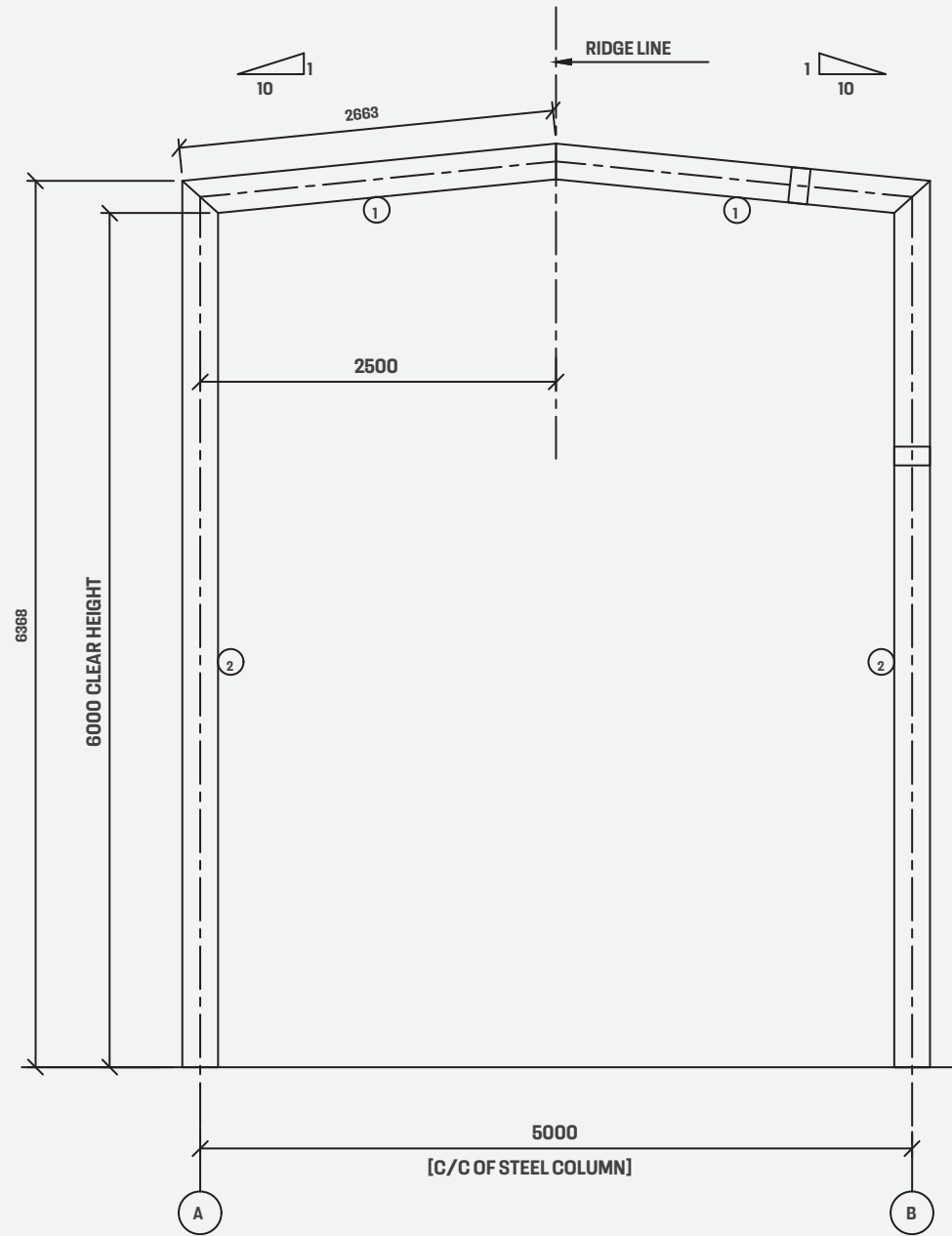

MEMBER SIZE SCHEDULE

Wind speed 39m/s, Earthquake Zone-IV				
Part Mark	Description	Length(MM)	Grade	Weight/Frame (Kg)
Designed with YST 210 & 310MPa				
1	250X100X2.9 (RHS)	5326	210MPa	82
2	250X100X4.0 (RHS)	12736	310MPa	268
Total Weight				350
Designed with YST 210MPa only				
1	250X100X2.9 (RHS)	5326	210MPa	82
2	280X100X5.0 (RHS)	12736	210MPa	362
Total Weight				444

Design - 1 (A)

Wind speed 47m/s, Earthquake Zone-IV				
Part Mark	Description	Length(MM)	Grade	Weight/Frame (Kg)
Designed with YST 210 & 310MPa				
1	280X100X3.2 (RHS)	5326	210MPa	99
2	280X100X5.0 (RHS)	12736	310MPa	369
Total Weight				463
Designed with YST 210MPa only				
1	280X100X3.2 (RHS)	5326	210MPa	99
2	300X150X5.4 (RHS)	12736	210MPa	467
Total Weight				566

Design - 1 (B)

Wind speed 55m/s, Earthquake Zone-IV				
Part Mark	Description	Length(MM)	Grade	Weight/Frame (Kg)
Designed with YST 310MPa only				
1	250X100X4.0 (RHS)	5326	310MPa	113
2	300X150X5.0 (RHS)	12736	310MPa	431
Total Weight				544
Designed with YST 210MPa only				
1	280X100X5.0 (RHS)	5326	210MPa	152
2	300X150X8.0 (RHS)	12736	210MPa	678
Total Weight				830

Design - 1 (C)

Note :
• Length tolerance ± 50mm | • Weight tolerance ± 5%

PORTAL FRAME

DESIGN - 02

10 METER . SPAN | BAY SPACING - 6.0 METER
SLOPE - 1:10

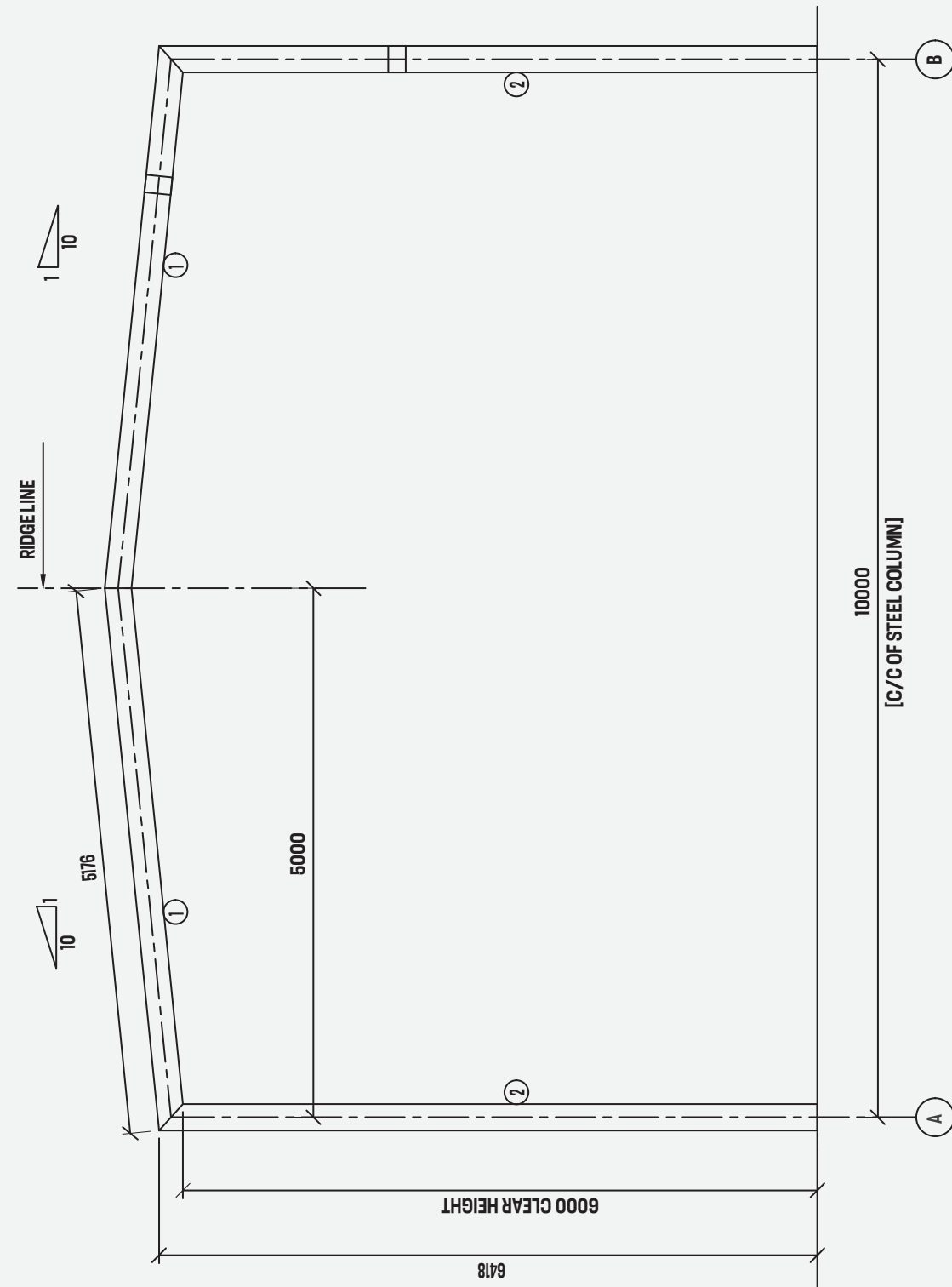

MEMBER SIZE SCHEDULE

Wind Speed 39m/S, Earthquake Zone-Iv				
Part Mark	Description	Length(Mm)	Grade	Weight/Frame (Kg)
Designed With YST 310MPa Only				
1	280x100x4.0 (Rhs)	10352	310mpa	238
2	280x100x4.0 (Rhs)	12836	310mpa	245
Total Weight				533
Designed With YST 210MPa				
1	280x100x5.4 (Rhs)	10352	210mpa	317
2	280x100x5.4 (Rhs)	12836	210mpa	393
Total Weight				710

Design - 2 (A)

Wind Speed 47m/S, Earthquake Zone-Iv				
Part Mark	Description	Length(Mm)	Grade	Weight/Frame (Kg)
Designed With YST 310MPa Only				
1	280x100x5.0 (Rhs)	10352	310mpa	295
2	280x100x5.0 (Rhs)	12836	310mpa	365
Total Weight				660
Designed With YST 210MPa				
1	300x150x5.0 (Rhs)	10352	210mpa	352
2	300x150x5.4 (Rhs)	12836	210mpa	470
Total Weight				822

Design - 2 (B)

Wind Speed 55m/S, Earthquake Zone-Iv				
Part Mark	Description	Length(Mm)	Grade	Weight/Frame (Kg)
Designed With YST 310MPa Only				
1	300x150x5.0 (Rhs)	10352	310mpa	352
2	300x150x5.0 (Rhs)	12836	310mpa	437
Total Weight				789
Designed With YST 210MPa				
1	300x200x6.0 (Rhs)	10352	210mpa	468
2	300x150x8.0 (Rhs)	12836	210mpa	683
Total Weight				1151

Design - 2 (C)

Note :
• Length tolerance ± 50mm | • Weight tolerance ± 5%

PORTAL FRAME

DESIGN - 03

15 METER . SPAN | BAY SPACING - 6.0 METER
SLOPE - 1:10

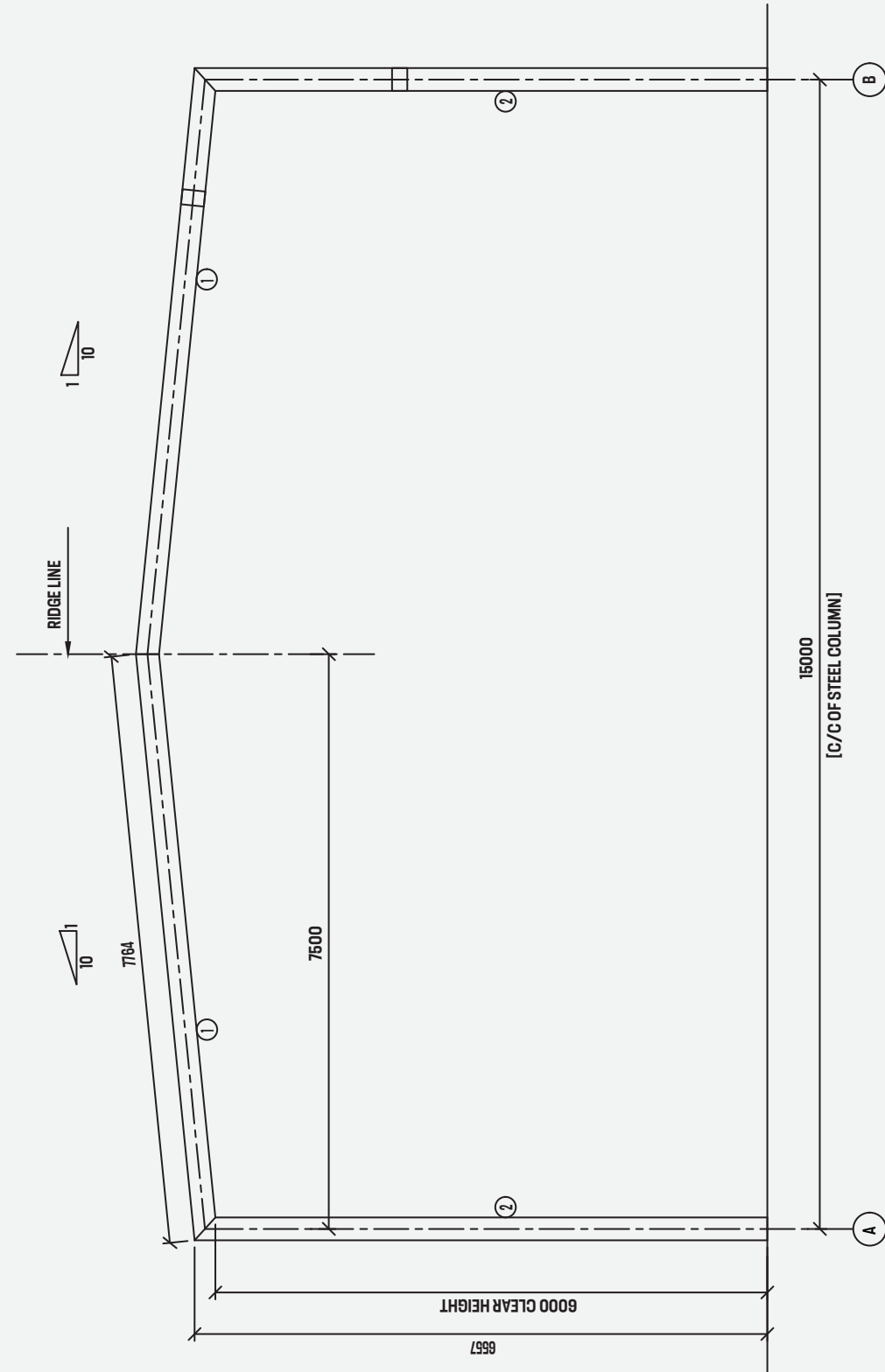

MEMBER SIZE SCHEDULE

Wind speed 39m/s, Earthquake Zone-IV				
Part mark	Description	Length(mm)	Grade	Weight/frame (Kg)
Designed with YST 310MPa only				
1	350X150X5.0 (RHS)	15528	310MPa	586.00
2	350X150X5.0 (RHS)	13114	310MPa	491.00
Total Weight				1077.00
Designed with YST 210MPa only				
1	400X200X5.4 (RHS)	15528	210MPa	764
2	400X200X5.4 (RHS)	13114	210MPa	643
Total Weight				1407

Design - 3 (A)

Wind speed 47m/s, Earthquake Zone-IV				
Part mark	Description	Length(mm)	Grade	Weight/frame (Kg)
Designed with YST 310MPa only				
1	350X150X5.0 (RHS)	15528	310MPa	586
2	350X150X5.0 (RHS)	13114	310MPa	491
Total Weight				1076
Designed with YST 210MPa only				
1	400X200X5.4 (RHS)	15528	210MPa	764
2	400X200X5.4 (RHS)	13114	210MPa	643
Total Weight				1407

Design - 3 (B)

Wind speed 55m/s, Earthquake Zone-IV				
Part mark	Description	Length(mm)	Grade	Weight/frame (Kg)
Designed with YST 310MPa only				
1	400X150X5.4 (RHS)	15528	310MPa	700
2	400X150X5.0 (RHS)	13114	310MPa	550
Total Weight				1250
Designed with YST 210MPa only				
1	450X200X5.4 (RHS)	15528	210MPa	832
2	450X200X5.4 (RHS)	13114	210MPa	703
Total Weight				1535

Design - 3 (C)

Note :
• Length tolerance ± 50mm | • Weight tolerance ± 5%

DESIGN - 04

15 METER . SPAN | BAY SPACING - 6.0 METER

SLOPE - 1:10

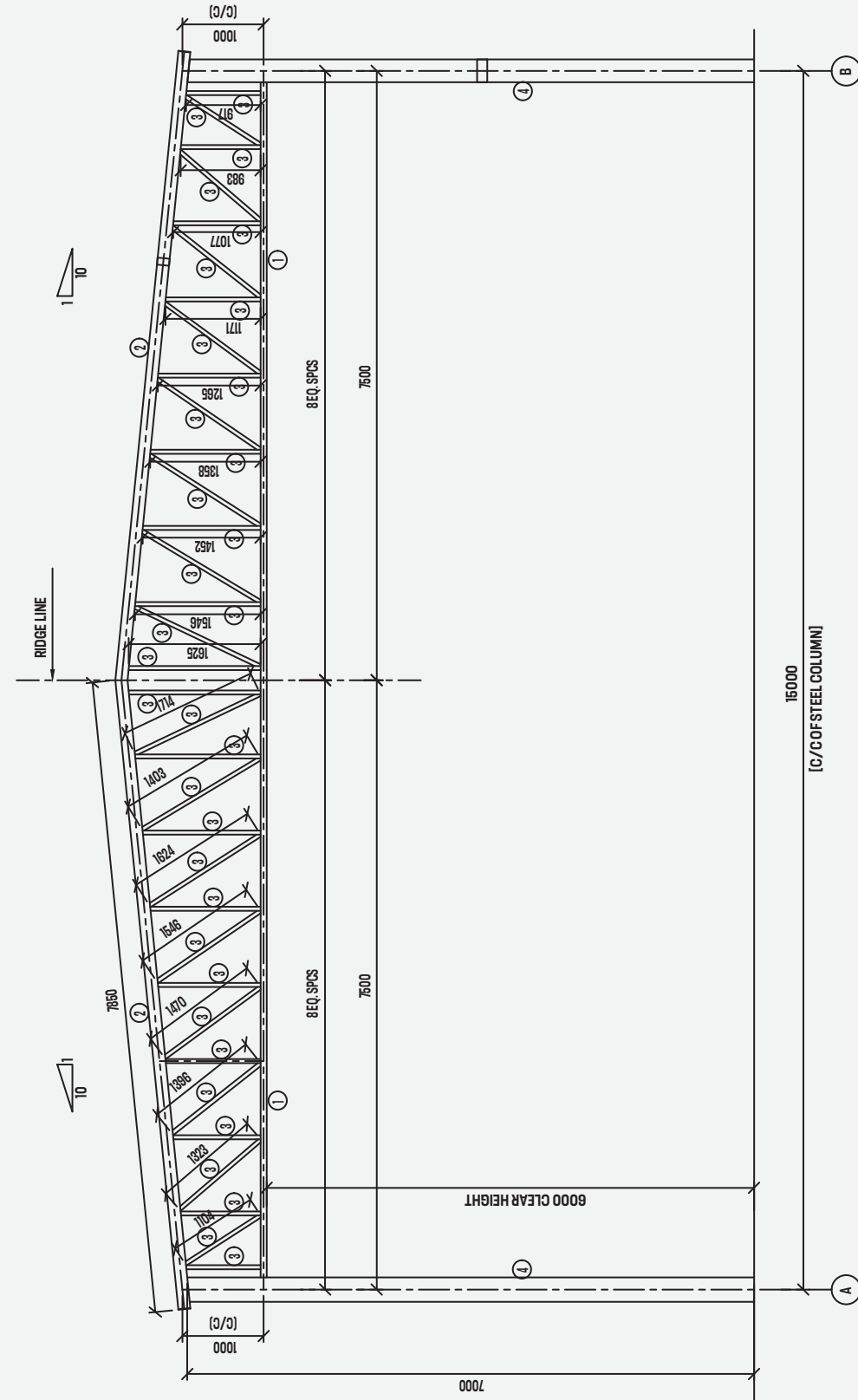

MEMBER SIZE SCHEDULE

Wind speed 39m/s, Earthquake Zone-IV

Part mark	Description	Length(mm)	Grade	Weight/frame (Kg)
Designed with YST 210 & 310MPa				
1	110X110X3.2 (SHS)	14750	210MPa	156
2	150X75X2.9 (RHS)	15700	210MPa	154
3	50X50X2.9 (SHS)	46550	210MPa	192
4	250X100X4.0 (RHS)	14000	310MPa	296
Total Weight				798
Designed with YST 210MPa only				
1	110X110X3.2 (RHS)	14700	210MPa	155
2	150X75X2.9 (RHS)	15700	210MPa	154
3	50X50X2.9 (SHS)	46550	210MPa	192
4	300X150X4.0 (RHS)	14000	210MPa	384
Total Weight				885

Design - 4 (A)

Wind speed 47m/s, Earthquake Zone-IV

Part mark	Description	Length(mm)	Grade	Weight/frame (Kg)
Designed with YST 210 & 310MPa				
1	150X75X3.2 (RHS)	14750	210MPa	159
2	150X75X2.9 (RHS)	15700	210MPa	154
3	50X50X3.2 (SHS)	46550	210MPa	209
4	280X100X5.0 (RHS)	14000	310MPa	400
Total Weight				923
Designed with YST 210MPa only				
1	150X75X3.2 (RHS)	14700	210MPa	159
2	150X75X2.9 (RHS)	15700	210MPa	154
3	50X50X3.2 (SHS)	46550	210MPa	210
4	300X150X5.4 (RHS)	14000	210MPa	513
Total Weight				1036

Design - 4 (B)

Wind speed 55m/s, Earthquake Zone-IV

Part mark	Description	Length(mm)	Grade	Weight/frame (Kg)
Designed with YST 210 & 310MPa				
1	200X100X3.2 (RHS)	14750	210MPa	215
2	150X75X3.2 (RHS)	15700	210MPa	169
3	72X72X2.9 (SHS)	46550	210MPa	285
4	300X150X5.0 (RHS)	14000	310MPa	477
Total Weight				1146
Designed with YST 210MPa only				
1	200X100X2.9 (RHS)	14700	210MPa	195
2	150X75X3.2 (RHS)	15700	210MPa	169
3	72X72X2.9 (SHS)	46550	210MPa	285
4	400X150X5.0 (RHS)	14000	210MPa	587
Total Weight				1236

Design - 4 (C)

Note :
 • Length tolerance ± 50mm | • Weight tolerance ± 5%

DESIGN - 05

20 METER . SPAN | BAY SPACING - 6.0 METER
SLOPE - 1:10

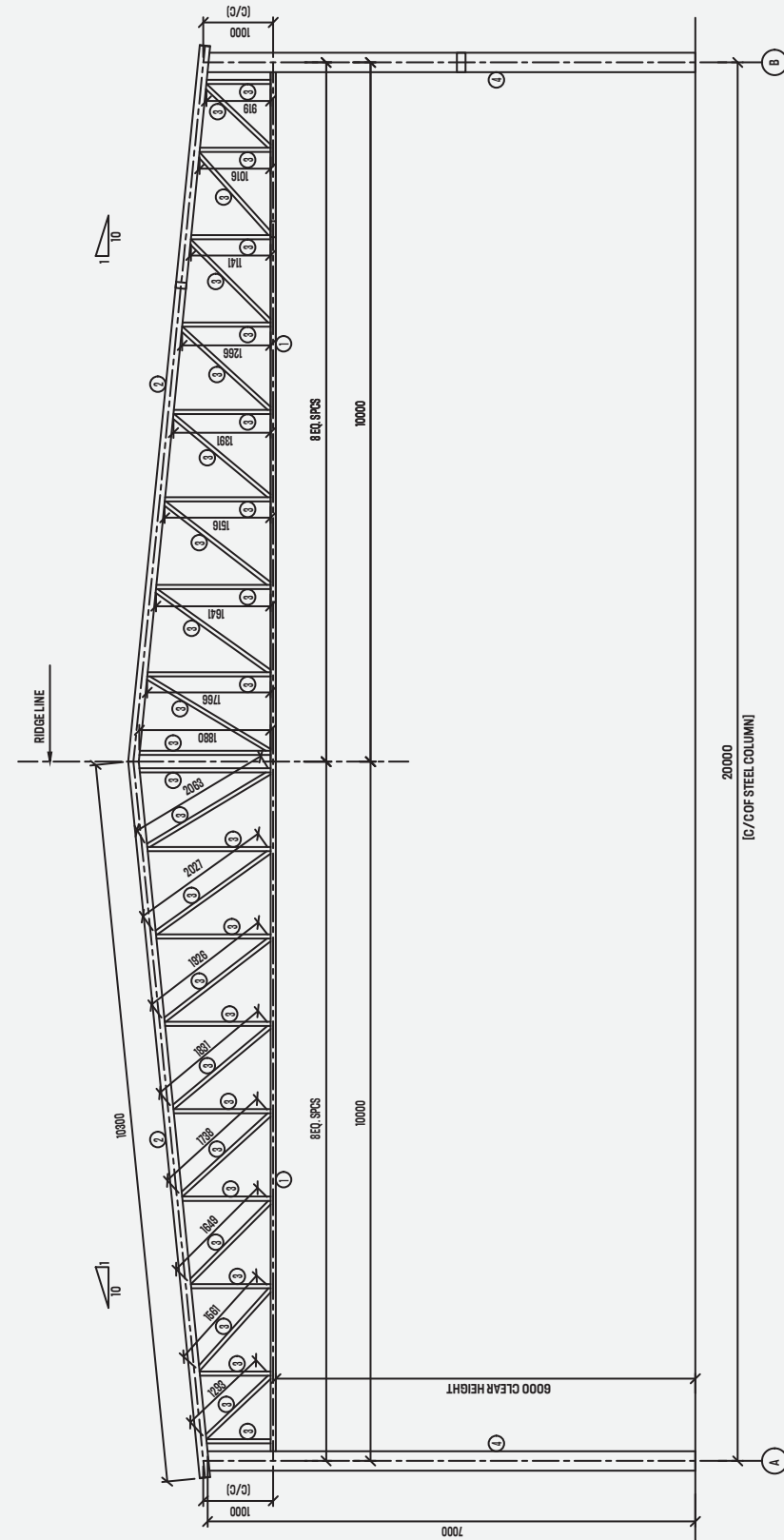

MEMBER SIZE SCHEDULE

Wind speed 39m/s, Earthquake Zone-IV

Part Mark	Description	Length(Mm)	Grade	Weight/Frame (Kg)
Designed with YST 210 & 310MPa				
1	150X75X3.6 (RHS)	19750	210MPa	238
2	150X100X3.6 (RHS)	20600	210MPa	277
3	60X60X3.6 (SHS)	53250	210MPa	326
4	250X100X4.0 (RHS)	14000	310MPa	296
Total Weight				1137
Designed with YST 210MPa only				
1	150X75X3.6 (RHS)	19750	210MPa	238
2	150X75X3.6 (RHS)	20600	210MPa	277
3	60X60X3.6 (SHS)	53250	210MPa	326
4	280X100X5.0 (RHS)	14000	210MPa	400
Total Weight				1241

Design - 5 (A)

Wind speed 47m/s, Earthquake Zone-IV

Part Mark	Description	Length(Mm)	Grade	Weight/Frame (Kg)
Designed with YST 210 & 310MPa				
1	200X100X3.2 (RHS)	19750	210MPa	287
2	150X100X3.2 (RHS)	20600	210MPa	248
3	60X60X3.6 (SHS)	53250	210MPa	326
4	280X100X5.0 (RHS)	14000	310MPa	400
Total Weight				1261
Designed with YST 210MPa only				
1	150X100X3.6 (RHS)	19750	210MPa	266
2	150X100X3.2 (RHS)	20600	210MPa	248
3	60X60X3.6 (SHS)	53250	210MPa	326
4	300X150X5.0 (RHS)	14000	210MPa	477
Total Weight				1317

Design - 5 (B)

Wind speed 55m/s, Earthquake Zone-IV

Part Mark	Description	Length(Mm)	Grade	Weight/Frame (Kg)
Designed with YST 210 & 310MPa				
1	200X100X3.6 (RHS)	19750	210MPa	322
2	150X50X4.0 (RHS)	20600	310MPa	242
3	100X100X3.2 (SHS)	53250	210MPa	507
4	300X150X5.0 (RHS)	14000	310MPa	477
Total Weight				1548
Designed with YST 210MPa only				
1	200X100X3.6 (RHS)	19750	210MPa	322
2	200X100X4.0 (RHS)	20600	210MPa	371
3	100X100X3.2 (SHS)	53250	210MPa	507
4	300X200X6.0 (RHS)	14000	210MPa	633
Total Weight				1833

Design - 5 (C)

Note :
• Length tolerance ± 50mm | • Weight tolerance ± 5%

DESIGN - 06

25 METER . SPAN | BAY SPACING - 6.0 METER
SLOPE - 1:10

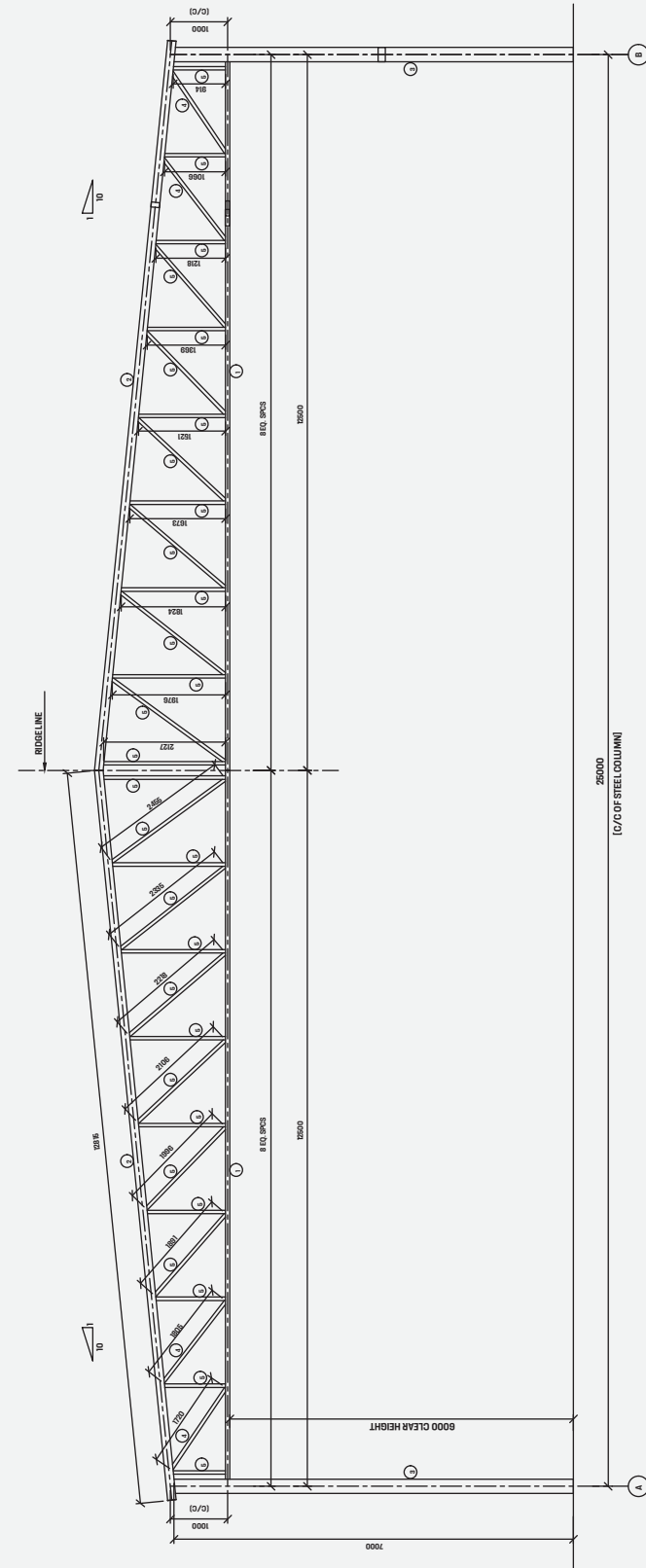

MEMBER SIZE SCHEDULE

Wind speed 39m/s, Earthquake Zone-IV				
Part Mark	Description	Length(Mm)	Grade	Weight/Frame (Kg)
Designed with YST 210 & 310MPa				
1	150X75X4.0 (RHS)	24750	310MPa	329
2	150X75X4.0 (RHS)	25630	310MPa	341
3	250X100X4.0 (RHS)	14000	310MPa	296
4	100X100X2.9 (SHS)	7050	210MPa	61
5	60X60X2.9 (SHS)	53360	210MPa	263
Total Weight				1291
Designed with YST 210MPa only				
1	200X100X4.5 (RHS)	24750	210MPa	499
2	200X100X4.5 (RHS)	25630	210MPa	516
3	300X150X4.0 (RHS)	14000	210MPa	384
4	100X100X2.9 (SHS)	7050	210MPa	61
5	60X60X2.9 (SHS)	53360	210MPa	263
Total Weight				1723

Design - 6 (A)

Wind speed 47m/s, Earthquake Zone-IV				
Part Mark	Description	Length(Mm)	Grade	Weight/Frame (Kg)
Designed with YST 210 & 310MPa				
1	200X100X3.6 (RHS)	24750	310MPa	403
2	150X100X4.0 (RHS)	25630	310MPa	381
3	280X100X5.0 (RHS)	14000	310MPa	400
4	110X110X2.6 (SHS)	7050	210MPa	61
5	60X60X2.9 (SHS)	53360	210MPa	263
Total Weight				1508
Designed with YST 210MPa only				
1	200X100X4.5 (RHS)	24750	210MPa	499
2	200X100X4.5 (RHS)	25630	210MPa	517
3	300X150X5.0 (RHS)	14000	210MPa	477
4	110X110X2.6 (SHS)	7050	210MPa	61
5	60X60X2.6 (SHS)	53360	210MPa	263
Total Weight				1817

Design - 6 (B)

Note :
• Length tolerance ± 50mm | • Weight tolerance ± 5%

TRUSS FRAME

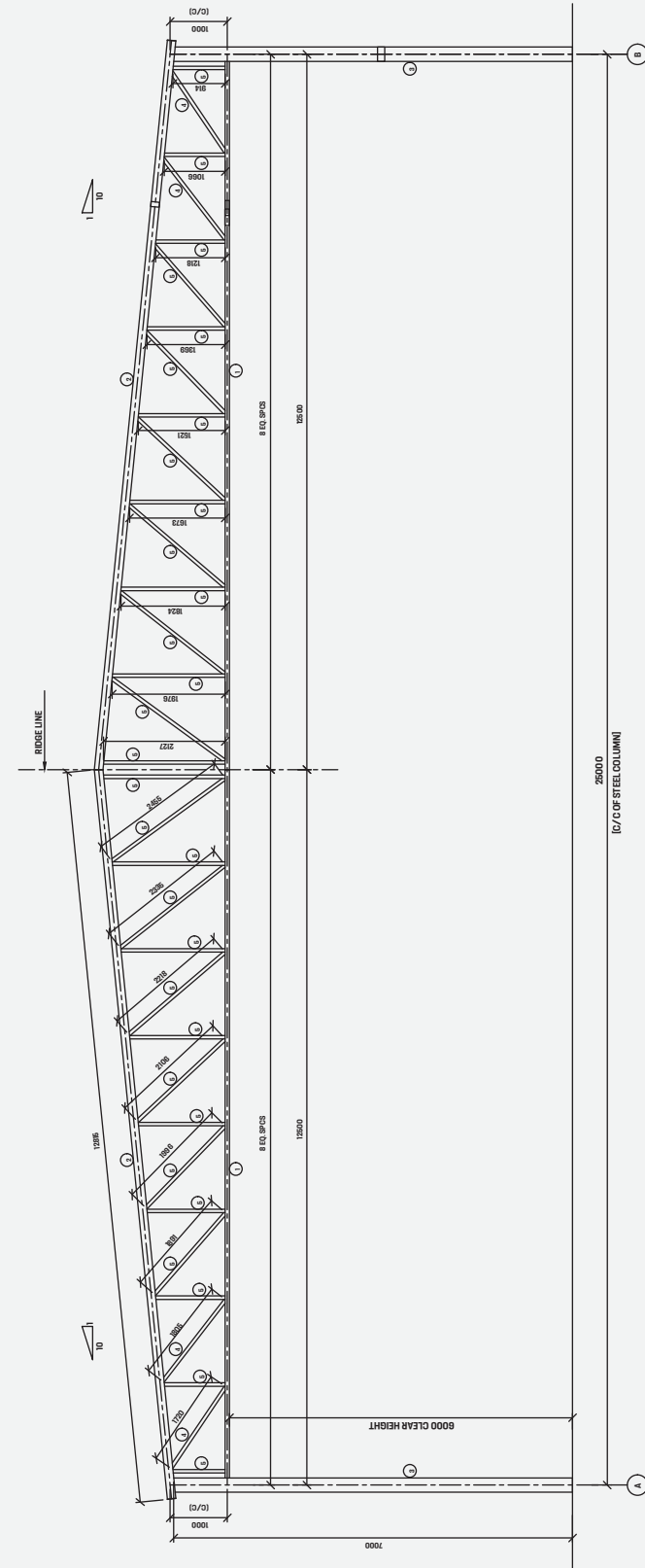

Wind Speed 55m/S, Earthquake Zone-Iv

Part Mark	Description	Length(Mm)	Grade	Weight/Frame (Kg)
Designed With YST 210 & 310MPa				
1	200x100x4.0 (Rhs)	24750	310MPa	446
2	150x100x4.0 (Rhs)	25630	310MPa	381
3	300x150x5.0 (Rhs)	14000	310MPa	477
4	125x125x2.9 (Shs)	7050	210MPa	77
5	75x75x2.9 (Shs)	53064	210MPa	339
	Total Weight			1720
Designed With YST 210MPa Only				
1	200x100x5.0 (Rhs)	24750	210MPa	551
2	200x100x4.5 (Rhs)	25630	210MPa	517
3	300x200x6.0 (Rhs)	14000	210MPa	633
4	125x125x2.9 (Shs)	7050	210MPa	77
5	75x75x2.9 (Shs)	53075	210MPa	340
	Total Weight			2118

Design - 6 (C)

Note :

• Length tolerance ± 50 mm | • Weight tolerance $\pm 5\%$

TRUSS FRAME

DESIGN - 07

30 METER . SPAN | BAY SPACING - 6.0 METER
SLOPE - 1:10

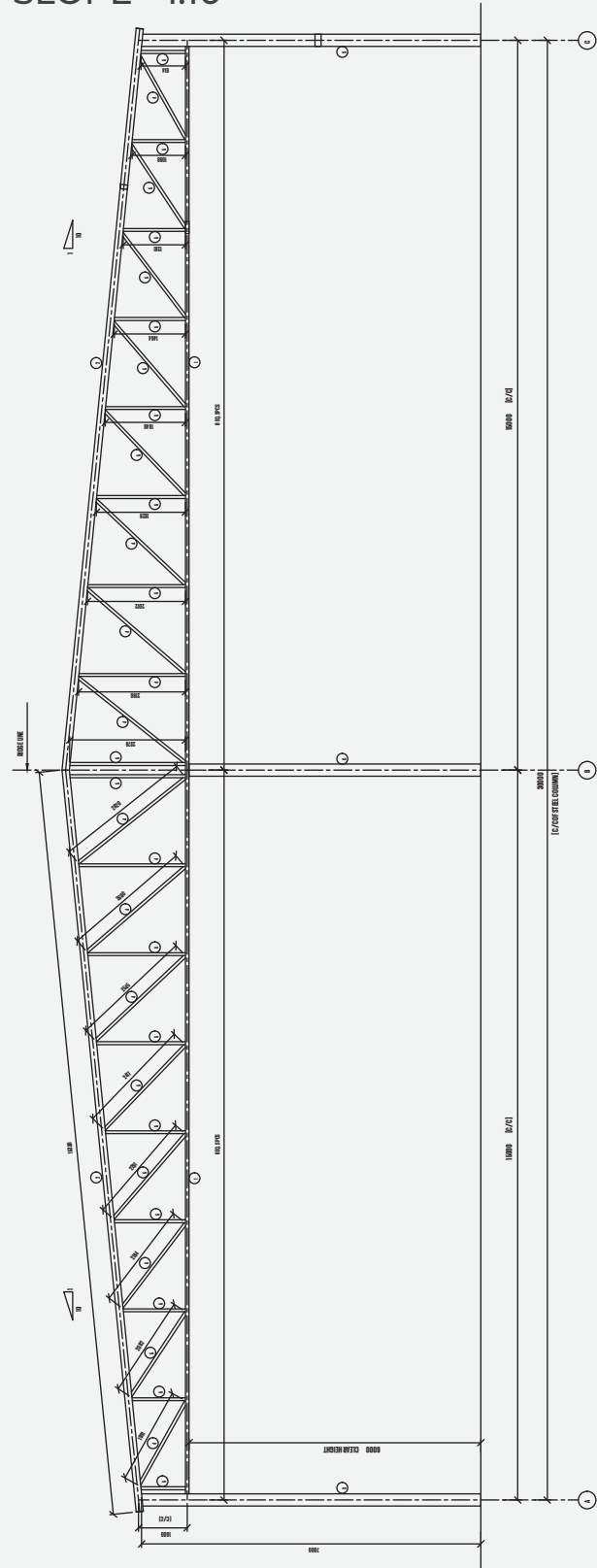

MEMBER SIZE SCHEDULE

Wind speed 39m/s, Earthquake Zone-IV

Part Mark	Description	Length(Mm)	Grade	Weight/Frame (Kg)
Designed with YST 210 & 310MPa				
1	150x50x2.8 (RHS)	29750	210MPa	249
2	150x50x2.8 (RHS)	30660	210MPa	257
3	250x100x4.0 (RHS)	14000	310MPa	296
4	80x80x2.6 (SHS)	24460	210MPa	151
5	60x60x2.6 (SHS)	43185	210MPa	197
6	140x140x3.2 (SHS)	6000	210MPa	81
Total Weight				1231
Designed with YST 210MPa only				
1	150x50x2.8 (RHS)	29750	210MPa	249
2	150x50x2.8 (RHS)	30660	210MPa	257
3	280x100x5.0 (RHS)	14000	210MPa	400
4	80x80x2.6 (SHS)	24460	210MPa	151
5	60x60x2.6 (SHS)	43185	210MPa	196
6	140x140x3.2 (SHS)	6000	210MPa	81
Total Weight				1334

Design - 7 (A)

Wind speed 47m/s, Earthquake Zone-IV

Part Mark	Description	Length(Mm)	Grade	Weight/Frame (Kg)
Designed with YST 210 & 310MPa				
1	150x75x2.9 (RHS)	29750	210MPa	292
2	150x50x2.8 (RHS)	30660	210MPa	257
3	280x100x5.0 (RHS)	14000	310MPa	400
4	80x80x2.6 (SHS)	24460	210MPa	151
5	60x60x2.6 (SHS)	43185	210MPa	197
6	140x140x3.2 (SHS)	6000	210MPa	81
Total Weight				1378
Designed with YST 210MPa only				
1	150x75x2.9 (RHS)	29750	210MPa	292
2	150x50x2.8 (RHS)	30660	210MPa	257
3	300x150x5.0 (RHS)	14000	210MPa	477
4	80x80x2.6 (SHS)	24460	210MPa	151
5	60x60x2.6 (SHS)	43185	210MPa	197
6	140x140x3.2 (SHS)	6000	210MPa	81
Total Weight				1455

Design - 7 (B)

Note :

• Length tolerance ± 50 mm | • Weight tolerance $\pm 5\%$

TRUSS FRAME

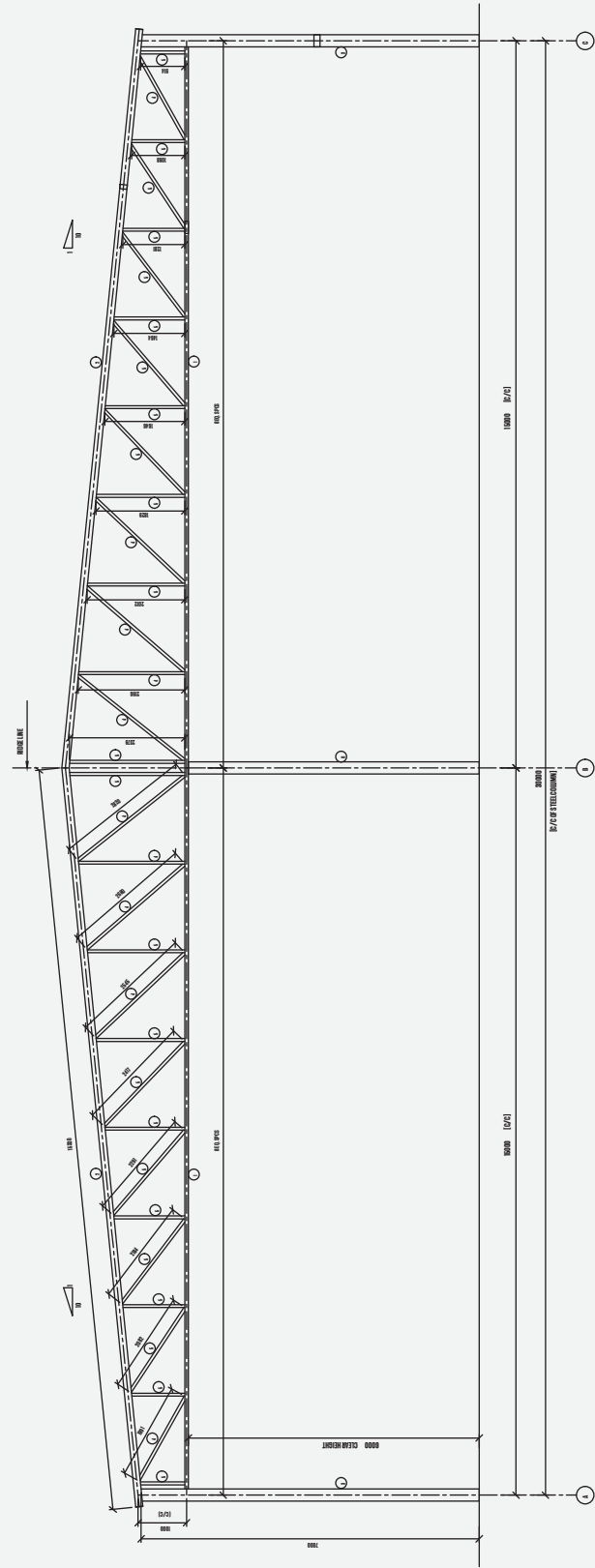

Design - 7 (C)

Wind speed 55m/s, Earthquake Zone-IV				
Part Mark	Description	Length(Mm)	Grade	Weight/Frame (Kg)
Designed with YST 210 & 310MPa				
1	200X100X3.2 (RHS)	29750	210MPa	433
2	150X75X3.2 (RHS)	30660	210MPa	331
3	300X150X5.0 (RHS)	14000	310MPa	477
4	91.5X91.5X2.6 (SHS)	24460	210MPa	174
5	60X60X2.6 (SHS)	43185	210MPa	197
6	140X140X3.2 (SHS)	6000	210MPa	81
Total Weight				1693
Designed with YST 210MPa only				
1	150X100X3.6 (RHS)	29750	210MPa	401
2	150X75X3.2 (RHS)	30660	210MPa	331
3	300X200X6.0 (RHS)	14000	210MPa	633
4	91.5X91.5X2.6 (SHS)	24460	210MPa	174
5	60X60X2.6 (SHS)	43185	210MPa	197
6	140X140X3.2 (SHS)	6000	210MPa	81
Total Weight				1817

Note :
 • Length tolerance $\pm 50\text{mm}$ | • Weight tolerance $\pm 5\%$

TRUSS FRAME

DESIGN - 08

30 METER . SPAN | BAY SPACING - 6.0 METER
SLOPE - 1:10

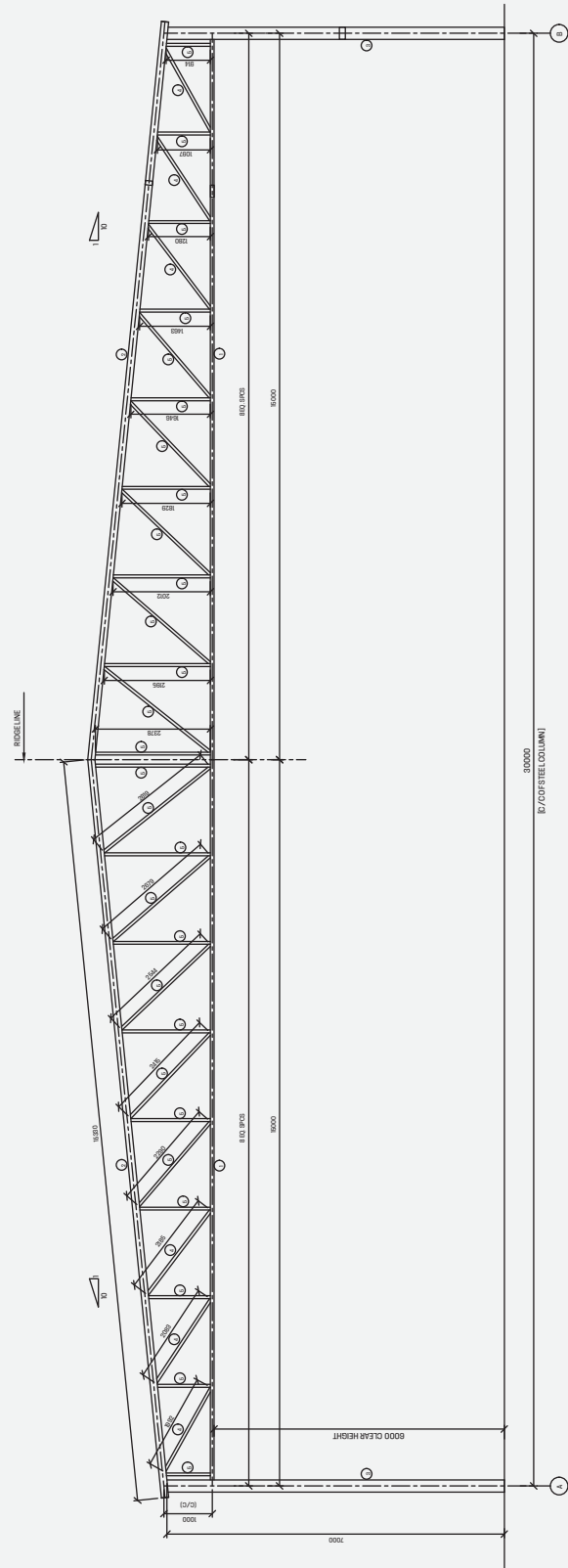

MEMBER SIZE SCHEDULE

Wind speed 39m/s, Earthquake Zone-IV

Part mark	Description	Length(mm)	Grade	Weight/frame (Kg)
Designed with YST 210 & 310MPa				
1	150x75x5.0 (RHS)	29750	310MPa	487
2	150x100x4.5 (RHS)	30660	310MPa	510
3	250x100x4.5 (RHS)	14000	310MPa	332
4	125x125x2.9 (SHS)	12520	210MPa	137
5	72x72x2.6 (SHS)	55115	210MPa	305
	Total weight			1771
Designed with YST 210MPa only				
1	200x100x5.0 (RHS)	29750	210MPa	662
2	250x100x5.0 (RHS)	30660	210MPa	803
3	280x100x5.4 (RHS)	14000	210MPa	430
4	125x125x2.9 (SHS)	12520	210MPa	137
5	72x72x2.6 (SHS)	55115	210MPa	305
	Total weight			2337

Design - 8 (A)

Wind speed 47m/s, Earthquake Zone-IV

Part mark	Description	Length(mm)	Grade	Weight/frame (Kg)
Designed with YST 210 & 310MPa				
1	200x100x5.0 (RHS)	29750	310MPa	662
2	200x100x4.5 (RHS)	30660	310MPa	618
3	280x100x4.5 (RHS)	14000	310MPa	361
4	125x125x2.9 (SHS)	12520	210MPa	137
5	72x72x2.6 (SHS)	53064	210MPa	294
	Total weight			2072
Designed with YST 210MPa only				
1	250x100x5.0 (RHS)	29750	210MPa	779
2	250x100x5.0 (RHS)	30660	210MPa	803
3	300x150x5.0 (RHS)	14000	210MPa	477
4	125x125x2.9 (SHS)	12520	210MPa	137
5	72x72x2.6 (SHS)	53075	210MPa	294
	Total weight			2490

Design - 8 (B)

Note :

• Length tolerance $\pm 50\text{mm}$ | • Weight tolerance $\pm 5\%$

TRUSS FRAME

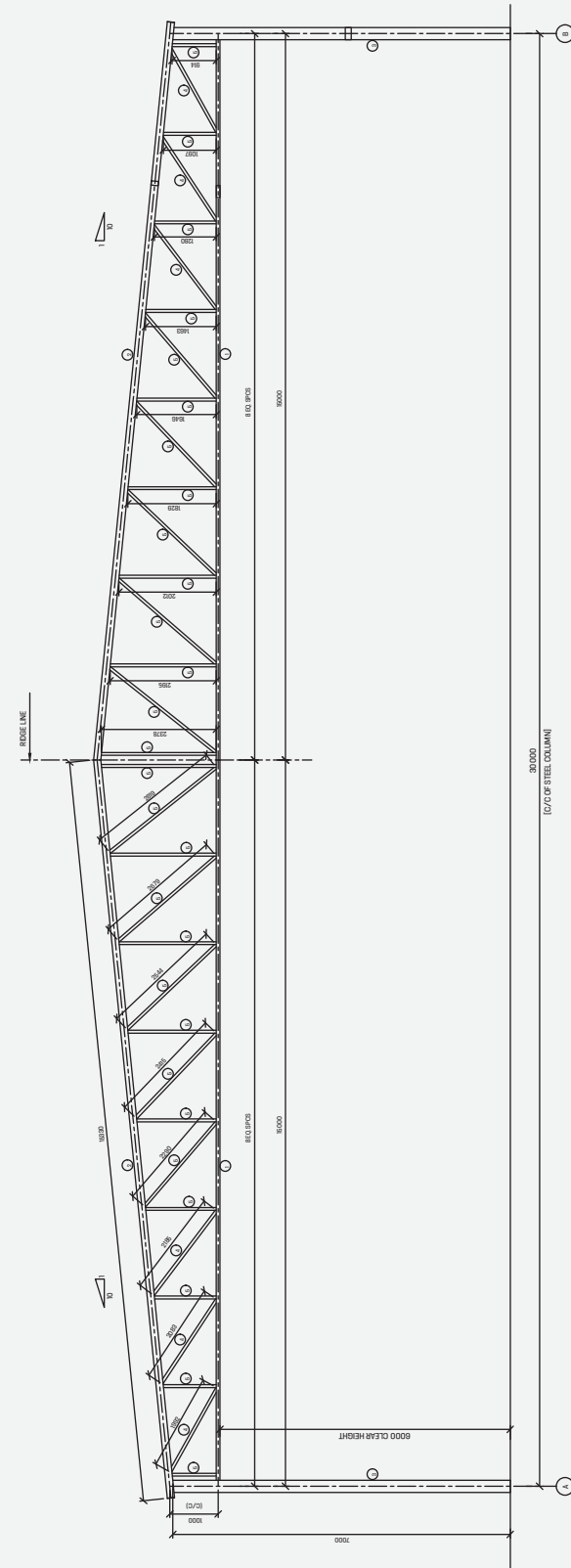

DESIGN - 8 (C)

Wind speed 55m/s, Earthquake Zone-IV				
Part Mark	Description	Length(Mm)	Grade	Weight/Frame (Kg)
Designed with YST 210 & 310MPa				
1	250x100x4.5 (RHS)	29750	310MPa	705
2	250x100x4.0 (RHS)	30660	310MPa	649
3	400x200x6.0 (RHS)	14000	310MPa	768
4	150x150x3.2 (SHS)	12520	210MPa	182
5	75x75x2.9 (SHS)	53064	210MPa	340
Total Weight				2644
Designed with YST 210MPa only				
1	250x100x5.0 (RHS)	29750	210MPa	786
2	250x100x4.5 (RHS)	30660	210MPa	727
3	500x200x6 (RHS)	14000	210MPa	897
4	150x150x3.2 (SHS)	12520	210MPa	182
5	75x75x2.9 (SHS)	53075	210MPa	340
Total Weight				2932

Note :
 • Length tolerance $\pm 50\text{mm}$ | • Weight tolerance $\pm 5\%$

PORTAL FRAME

DESIGN - 09

25 METER . SPAN | BAY SPACING - 6.0 METER
SLOPE - 1:10

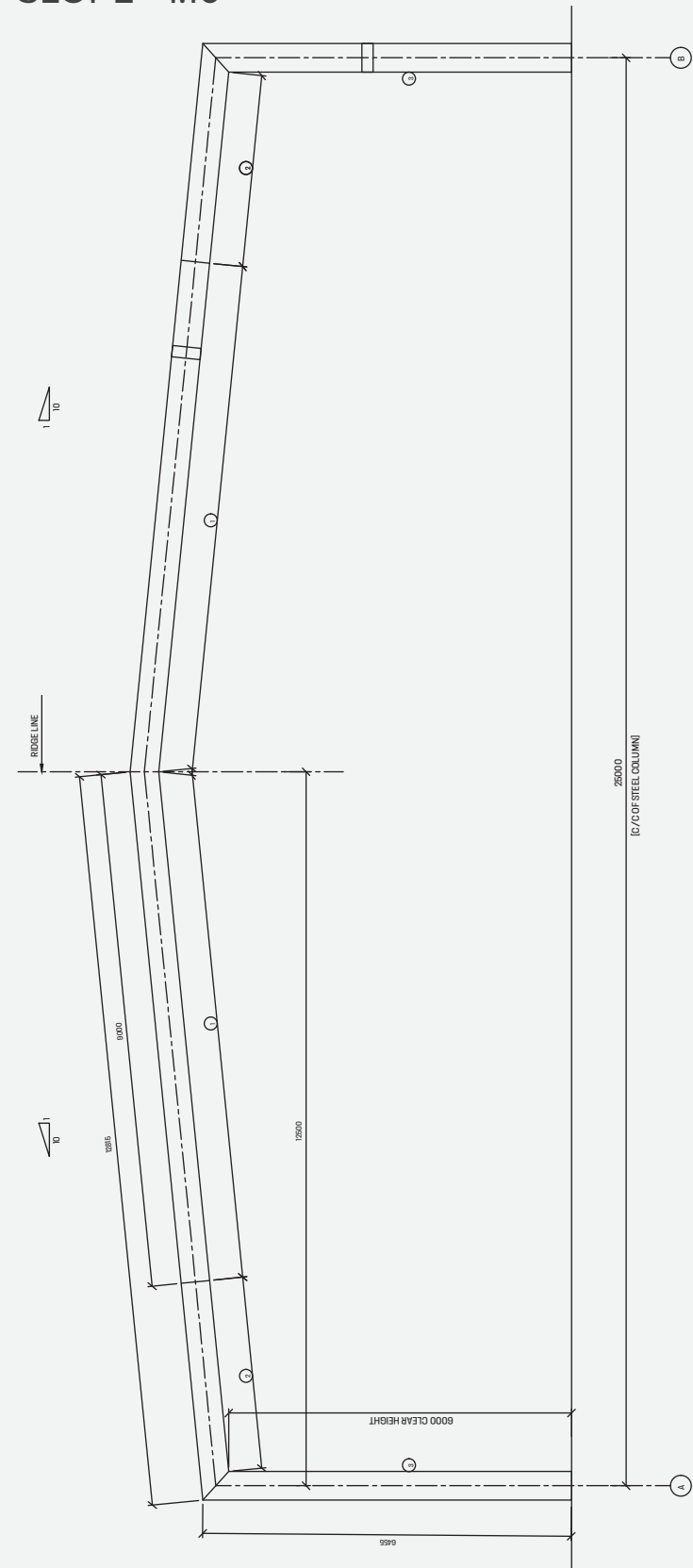

MEMBER SIZE SCHEDULE

Wind speed 39m/s, Earthquake Zone-IV

Part Mark	Description	Length(Mm)	Grade	Weight/Frame (Kg)
Designed with YST 310MPa only				
1	500x200x6.0 (RHS)	18000	310MPa	1154
2	500x200x8.0 (RHS)	7630	310MPa	646
3	500x200x8.0 (RHS)	12910	310MPa	1093
Total Weight				2893
Designed with YST 210MPa only				
1	500x200x6.0 (RHS)	18000	210MPa	1154
2	500x200x14.0 (RHS)	7630	210MPa	1097
3	500x200x14.0 (RHS)	12910	210MPa	1856
Total Weight				4107

Design - 9 (A)

Wind speed 47m/s, Earthquake Zone-IV

Part Mark	Description	Length(Mm)	Grade	Weight/Frame (Kg)
Designed with YST 310MPa only				
1	500x200x6.0 (RHS)	18000	310MPa	1154
2	500x200x8.0 (RHS)	7630	310MPa	646
3	500x200x8.0 (RHS)	12910	310MPa	1093
Total Weight				2893
Designed with YST 210MPa only				
1	500x200x6.0 (RHS)	18000	210MPa	1154
2	500x200x14.0 (RHS)	7630	210MPa	1097
3	500x200x14.0 (RHS)	12910	210MPa	1856
Total Weight				4107

Design - 9 (B)

Wind speed 55m/s, Earthquake Zone-IV

Part Mark	Description	Length(Mm)	Grade	Weight/Frame (Kg)
Designed with YST 310MPa only				
1	500x200x6.0 (RHS)	18000	310MPa	1154
2	500x200x10.0 (RHS)	7630	310MPa	800
3	500x200x10.0 (RHS)	12910	310MPa	1353
Total Weight				3307
Designed with YST 210MPa only				
1	500x200x6.0 (RHS)	18000	210MPa	1154
2	500x300x12.0 (RHS)	7630	210MPa	800
3	500x300x12.0 (RHS)	12910	210MPa	1850
Total Weight				4098

Design - 9 (C)

Note :
• Length tolerance ± 50mm | • Weight tolerance ± 5%

DESIGN - 10

30 METER . SPAN | BAY SPACING - 6.0 METER
SLOPE - 1:10

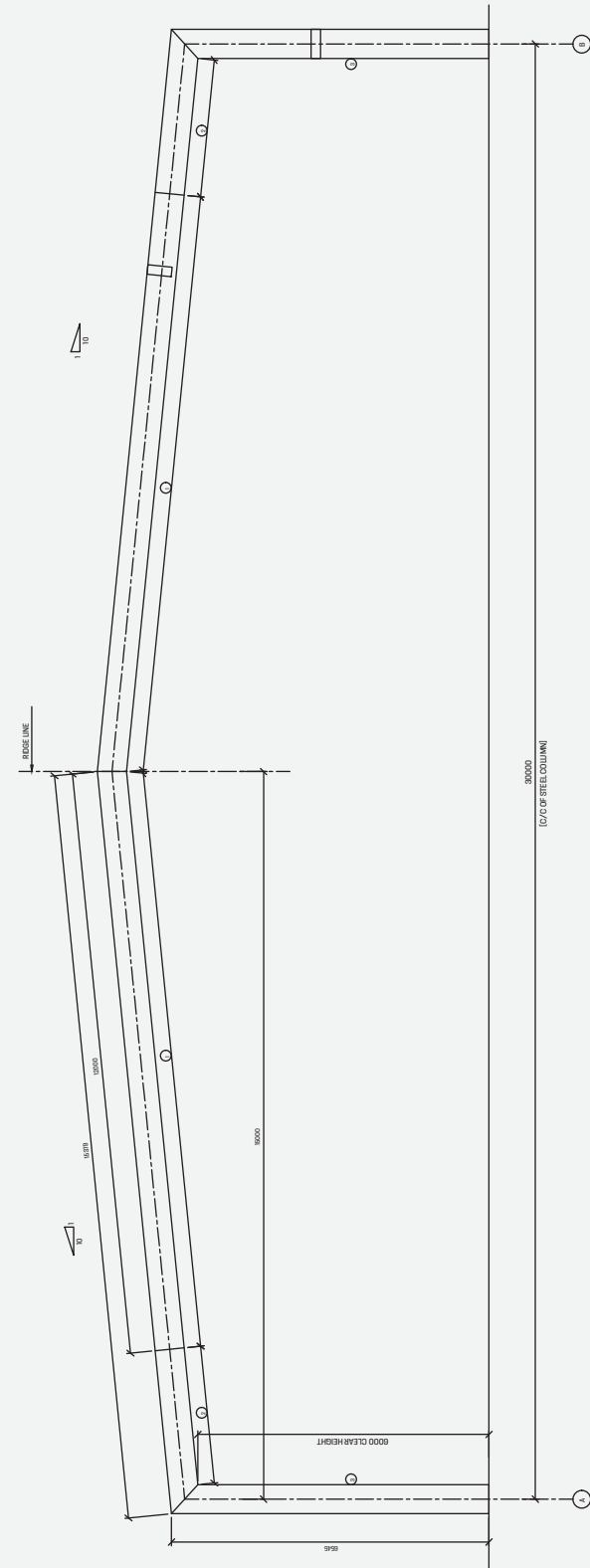

MEMBER SIZE SCHEDULE

Wind speed 39m/s, Earthquake Zone-IV

Part Mark	Description	Length(Mm)	Grade	Weight/Frame (Kg)
Designed with YST 310MPa only				
1	600x200x6.0 (RHS)	24000	310MPa	1764
2	600x200x10.0 (RHS)	6755	310MPa	814
3	600x200x10.0 (RHS)	13090	310MPa	1577
Total Weight				4155
Designed with YST 210MPa only				
1	600x200x8.0 (RHS)	24000	210MPa	2333
2	600x200x14.0 (RHS)	6755	210MPa	1120
3	600x200x14.0 (RHS)	13090	210MPa	2170
Total Weight				5623

Design - 10 (A)

Wind speed 47m/s, Earthquake Zone-IV

Part Mark	Description	Length(Mm)	Grade	Weight/Frame (Kg)
Designed with YST 310MPa only				
1	600x200x6.0 (RHS)	24000	310MPa	1764
2	600x200x10.0 (RHS)	6755	310MPa	646
3	600x200x10.0 (RHS)	13090	310MPa	1577
Total Weight				4155
Designed with YST 210MPa only				
1	600x200x8.0 (RHS)	24000	210MPa	2333
2	600x200x14.0 (RHS)	6755	210MPa	1120
3	600x200x14.0 (RHS)	13090	210MPa	2170
Total Weight				5623

Design - 10 (B)

Wind speed 55m/s, Earthquake Zone-IV

Part Mark	Description	Length(Mm)	Grade	Weight/Frame (Kg)
Designed with YST 310MPa only				
1	600x200x6.0 (RHS)	24000	310MPa	1764
2	600x200x10.0 (RHS)	6755	310MPa	814
3	600x200x10.0 (RHS)	13090	310MPa	1577
TOTAL WEIGHT				4155
Designed with YST 210MPa only				
1	600x200x8.0 (RHS)	24000	210MPa	2333
2	600x300x12.0 (RHS)	6755	210MPa	1096
3	600x300x12.0 (RHS)	13090	210MPa	2123
TOTAL WEIGHT				5552

Design - 10 (C)

Note :
• Length tolerance ± 50mm | • Weight tolerance ± 5%

TYPICAL CONNECTION DETAIL

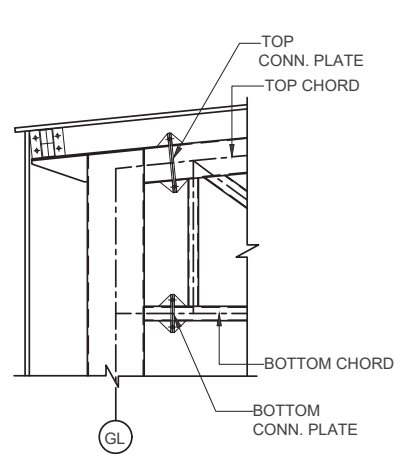

AT HAUNCH LOCATION

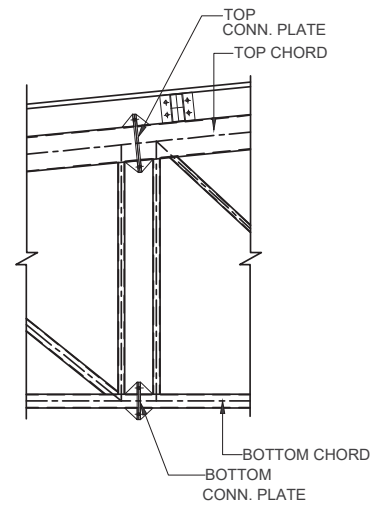

AT INTERMEDIATE LOCATION

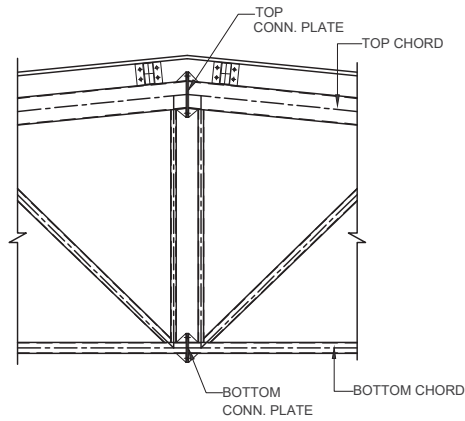

CONNECTION DETAIL AT RIDGE LOCATION

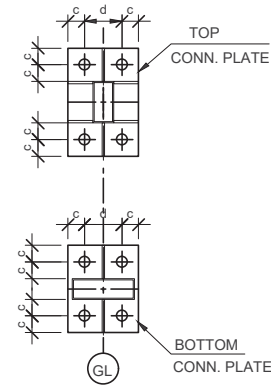

CONNECTION PLATE DETAIL FOR TOP & BOTTOM

CONNECTION BOLT PITCH & GAUGE SCHEDULE	
c	1.5D (D= DIA OF HOLE)
d	2.5D (D= DIA OF HOLE)

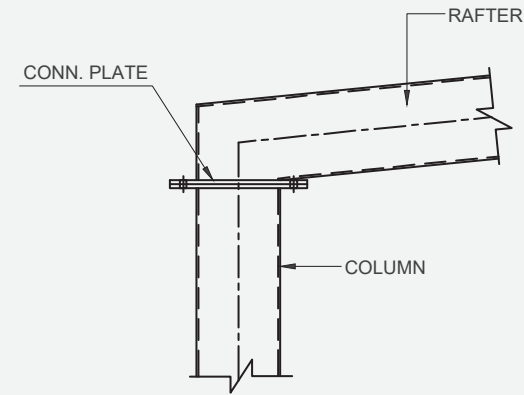

CONNECTION DETAIL AT HAUNCH LOCATION (OPTION-1)

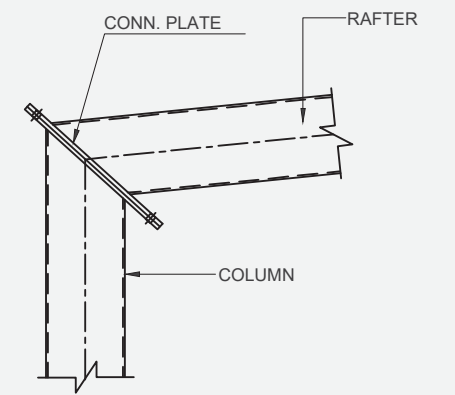

CONNECTION DETAIL AT HAUNCH LOCATION (OPTION-2)

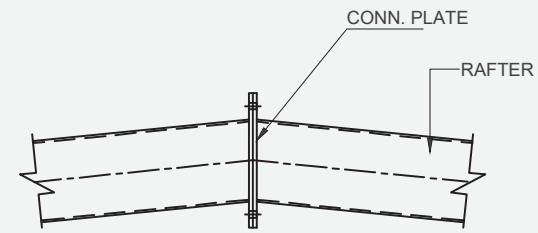

CONNECTION DETAIL AT RIDGE LOCATION

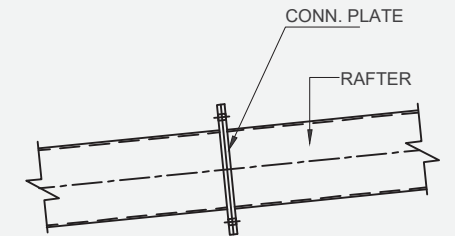

CONNECTION DETAIL AT INTERMEDIATE LOCATION

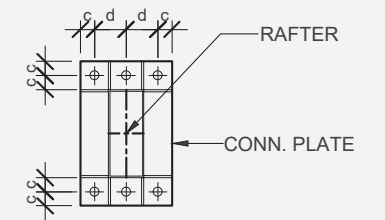

CONNECTION PLATE DETAIL

CONNECTION BOLT PITCH & GAUGE SCHEDULE	
c	1.5D (D= DIA OF HOLE)
d	2.5D (D= DIA OF HOLE)

TYPICAL CONNECTION DETAIL

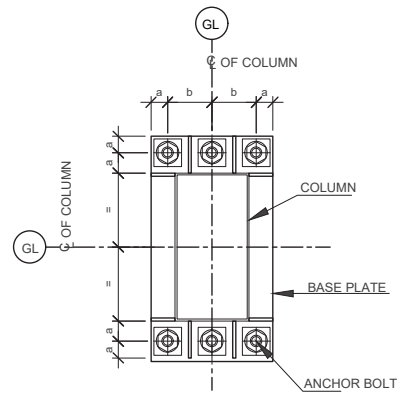

**6 Nos. BOLT DETAIL
(SIDE WALL & INTERMEDIATE COLUMN)**

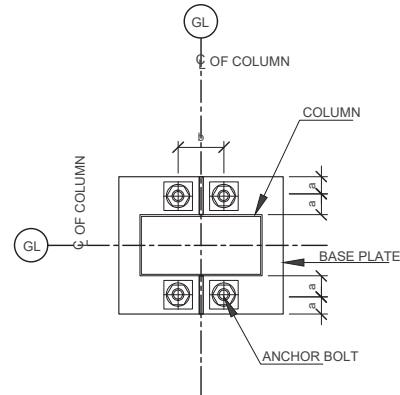

**4 Nos. BOLT DETAIL
(END WALL COLUMN)**

ANCHOR BOLT PITCH & GAUGE SCHEDULE	
a	2D (D= DIA OF HOLE)
b	4D (D= DIA OF HOLE)

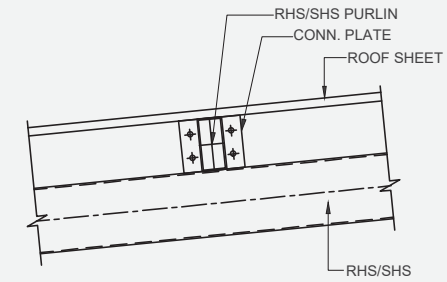

ROOF PURLIN CONNECTION DETAIL

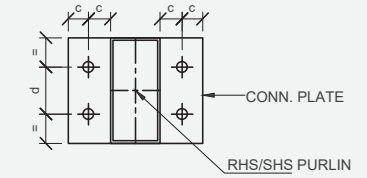

CONNECTION PLATE DETAIL OF PURLIN

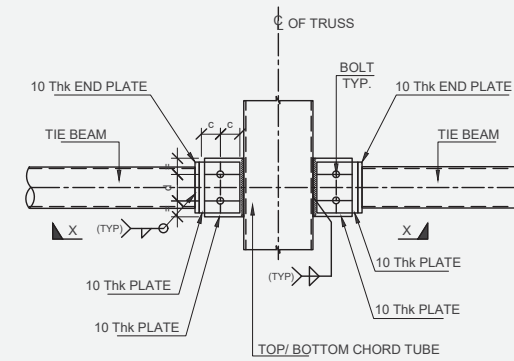

TIE BEAM CONNECTION DETAIL

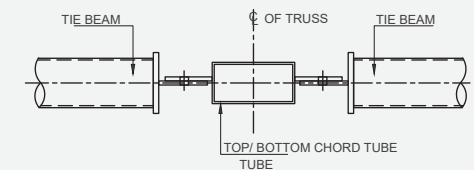

VIEW X-X

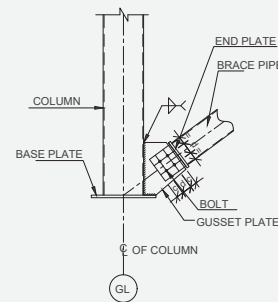

**PIPE BRACING DETAIL
COLUMN BASE**

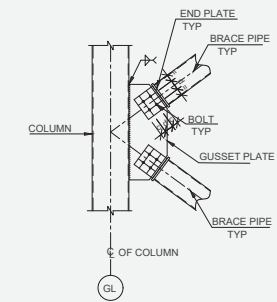

**PIPE BRACING INTERMEDIATE
LOCATION DETAIL**

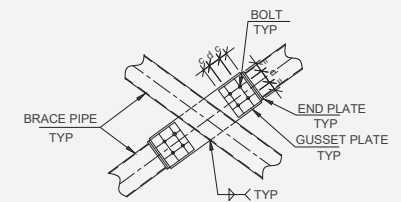

**PIPE BRACING DETAIL
INTERSECTION LOCATION**

CONNECTION BOLT PITCH & GAUGE SCHEDULE	
c	1.5D (D= DIA OF HOLE)
d	2.5D (D= DIA OF HOLE)

PURLINS, GIRTS, TIE & BRACING MEMBERS DETAILS

ROOF PURLINS							
S. No.	Wind Speed	Span - 6M		Span - 8M		Span - 10M	
		Size	Weight (Kg/M)	Size	Weight (Kg/M)	Size	Weight (Kg/M)
1	39	120x60x3.2	8.52	150x100x3.2	8.52	120x60x3.2	8.52
2	47	120x60x3.2	8.52	150x100x3.2	8.52	120x60x3.2	8.52
3	55	150x75x2.9	9.81	200x100x2.9	9.81	150x75x2.9	9.81

Purlin Span 1.5meter

WALL GIRTS							
S. No.	Wind Speed	Span - 6M		Span - 8M		Span - 10M	
		Size	Weight (Kg/M)	Size	Weight (Kg/M)	Size	Weight (Kg/M)
1	39	120x60x3.2	8.52	150x100x3.2	8.52	120x60x3.2	8.52
2	47	120x60x3.2	8.52	150x100x3.2	8.52	120x60x3.2	8.52
3	55	150x75x2.9	9.81	200x100x2.9	9.81	150x75x2.9	9.81

Girts Span 1.5meter

TIE MEMBERS							
S. No.	-	Span - 6M		Span - 8M		Span - 10M	
		Size	Weight (Kg/M)	Size	Weight (Kg/M)	Size	Weight (Kg/M)
1	-	CHS-76.0x2.6	4.72	CHS-101.6x2.6	3.5	CHS-127.0x2.9	8.88

BRACING MEMBERS							
S. No.	-	Span - 6M		Span - 8M		Span - 10M	
		Size	Weight (Kg/M)	Size	Weight (Kg/M)	Size	Weight (Kg/M)
1	-	CHS-76.0x2.6	4.72	CHS-101.6x2.6	3.5	CHS-127.0x2.9	8.88

ALLOWABLE STRESS VALUES (IN MPA) AND DIMENSIONAL TOLERANCE IS 4923:2017, TABLE 4, (Clauses 19.2)										
S. No.	Grade	Tensile Strength	Yield Strength	Elongation	DIMENSIONAL TOLERANCE					
		Min	Min	Min	Outside Dimensional	Thickness	Square-ness	Corner radius	Weight	
MPa	MPa	Percent	Individual Lengths	On lot of 10 MT						
1	YSt 210	330	210	20	+/-1% with a minimum of +/-0.50 min	±7.5%	90 deg. +/-2 deg.	3t max	10% -8%	±7%
2	YSt 240	410	240	15						
3	YSt 310	450	310	10						
4	YSt 355	490	355	10						

TENSILE PROPERTIES OF STEEL TUBES FOR STRUCTURAL PURPOSE IS 116:2014, TABLE, (Clauses 3.1 and 1.2)										
S. No.	Grade	Tensile Strength	Yield Strength	Elongation on Gauge Length	DIMENSIONAL TOLERANCE (Clause 6.2)					
		Min	Min	5.65√S ₀ Min	Outside Dimensional	Up to and including : ±0.4 mm		Weight	10 tonne lots	
MPa	MPa	Percent	48.3	Over 48.3 mm		Welded tube	Single tube			
1	YSt 210	330	210	20						
2	YSt 240	410	240	17						
3	YSt 310	450	310	14						
4	YSt 355	490	355	10						

Regardless of the above-mentioned sizes, any size up to 1000x1000 and thickness up to 40 mm can be manufactured

General Notes :-

Roof Trusses, Purlins, Side Girts etc. for industrial sheds are designed with cold finished RHS/SHS Manufactured by APL Apollo Tubes Ltd. Pitched roof trusses for rectangular clad buildings of 5 different spans and portal frames of 5 different spans for 39 Mps, 47Mps & 55mps wind speeds and each span having slopes of 1:10 have been considered to cover various practical combinations of roof systems and existing manufacturing practices in the India.

Truss configurations for different spans have been arrived at after trial and error, considering overall Economy & easily availability of Structural tubes. However, other configurations may also be tried.

Trusses have been analysed assuming rigid member to member connections except at ridge and hanger joints. The designs have been prepared for fixed supported conditions for column.

Trusses have been analysed for Dead Load, Superimposed Load, Wind Load and combinations Thereof according to IS: 875-2015. Only nodal loads have been considered for the purlins to be located strictly at node points, based on the maximum allowable span of Roofing sheet.

Wind Load & combinations has been taken from IS 875:2015 part III & IS800:2007 respectively and effective length of each member has been assumed to be 0.85 times the node to node distance. In case of compression loading, member has been designed against buckling in plane of truss. Maximum slenderness ratio for compression member has been restricted to 180. Maximum deflection of truss has been restricted to "span/180".

Typical fabrication detailing for different spans have been incorporated, so that practising structural engineers may find it helpful as a ready reference.

Design Code :

IS:806 & IS:800, use of hollow section for general construction in Steel Material : IS: 4923 Grade : YST 310 & 210

1. Dead Load

- i) Roofing sheeting & fastener = 0.05KN/m²
- ii) Purlins = As per Purlin Table
- iii) Truss, tie member etc = Actual RHS/SHS wt+ 5% of truss weight due to connection plate etc.

2. Imposed Load per m² plan area (for truss design):

Ref. IS : 875_1987_Part-2

Roof slope live Load = 0.75KN/m²

3. Wind Load :

IS : 875-2015, Part 3

Design Loading :

Wind Speed	39 MPS	47 MPS	55 MPS
Design Wind Pressure (KN/m ²)	0.735	1.066	1.459

COMPLETED TUBULAR SHEDS

INDUSTRIAL SHED, RAIPUR

Area : 350,000 Sqft

EOT : 30/40 Ton capacity (multiple cranes)

Clear Height : 12mtr | Span : 20mtr Multiple modules



INDUSTRIAL SHED, DUJANA

Area : 80,000 Sqft

EOT : 15 Ton capacity

Clear Height : 11mtr | Span : 27mtr & 22mtr



COLD STORAGE, KASHMIR

Area : 60,000Sqft

Clear Height : 12mtr | Span : 25mtr Multiple modules



INDUSTRIAL SHED, SATNA

Area : 24,210 Sqft

Clear Height : 12mtr | Span : 24mtr Multiple modules



INDUSTRIAL SHED, RAIPUR

Area : 150,000 Sqft

EOT : 30/40 Ton capacity (multiple cranes)

Clear Height : 12mtr | Span : 20mtr Multiple modules



TURBINE BUILDING, MEGHALAYA

Area : 25,000 Sqft

EOT : 20 Ton capacity

Clear Height : 14mtr | Span : 14mtr clear

