

REV	DATE	DESCRIPTION
00	06APR2021	INITIAL REVISION

NOTES:

- (⊥) ALL VERTICAL SUPPORTS ARE PERPENDICULAR.
- FLATNESS OF .5MM IS APPLIED BY DEFAULT.
- ⊥ WELD BEAD OF 2MM RADIUS IS FOLLOWED.
- ▽ SURFACE FINISH MEDIUM TO SMOOTH IS USED.
- ALL TUBES ARE AS PER APL APOLLO STANDARD. CHANGES MAY EFFECT THE LOAD CAPACITY.
- ALL HORIZONTAL AND VERTICAL TUBES ARE PERPENDICULAR TO EACH OTHER WITH ±1 DEG.
- FINE WELDING IS REQUIRED AS PER MENTIONED DETAILS AND FINISHING.
- HIGHER CURRENT WELDING MAY AFFECT THE BRITTLENESS OF MATERIAL WHICH LATER MAY RAISE TO WEAKENING OF STRUCTURE.
- FABRICATORS ARE ALLOWED TO USE FITTINGS/FRAMES/SUPPORTS AS NEEDED AND THE SAME MUST BE COMMUNICATED BACK TO ENGINEERING TEAM.
- BOP COMPONENT WEIGHTS ARE FOR REFERENCE ONLY AND SUBJECTED TO CHANGE PER PURCHASED COMPONENTS.

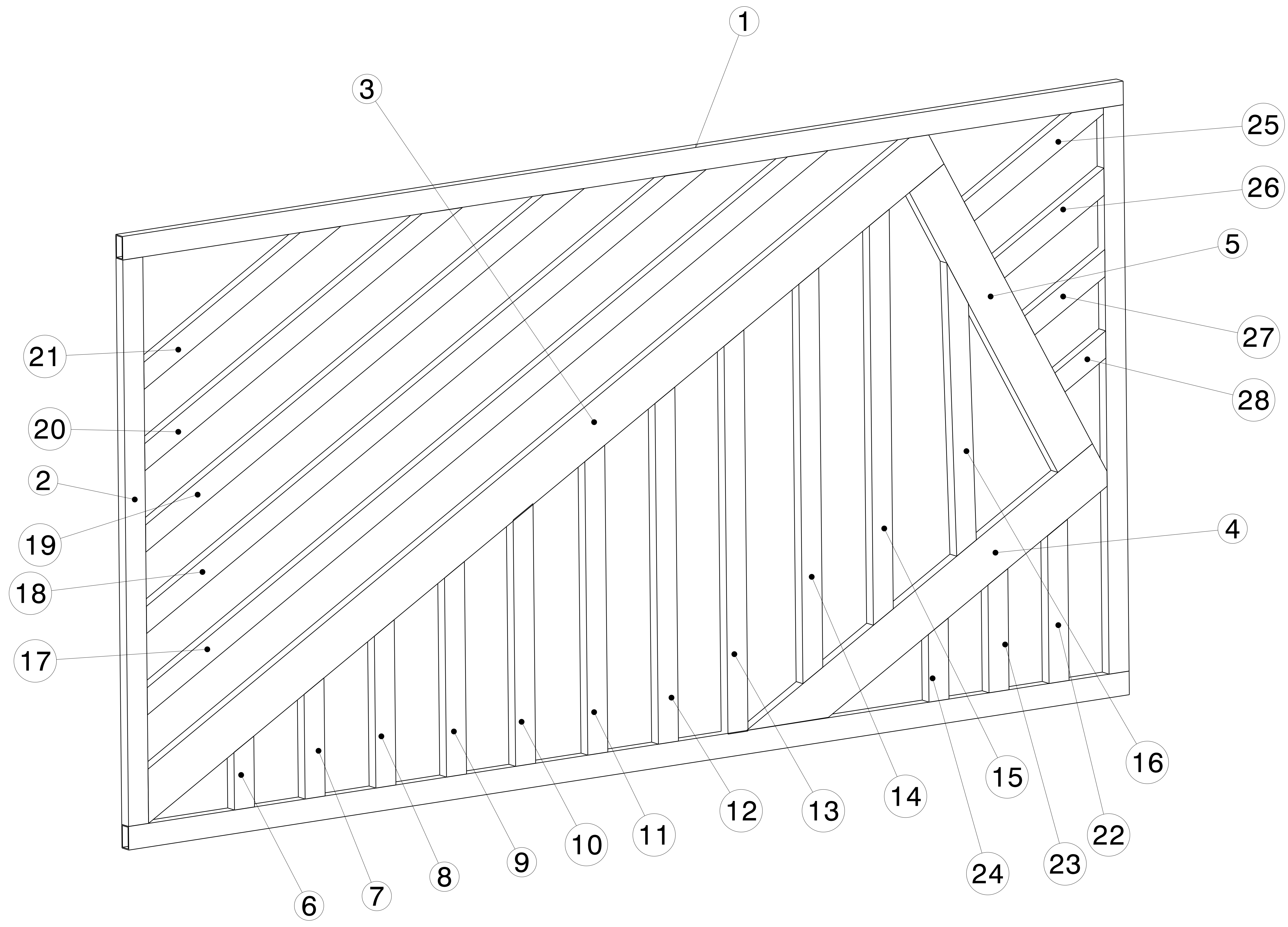

Isometric view
Scale: 1:4

ITEM NO.	PART NUMBER	DESCRIPTION	QTY.	Wt (kg) /Each
28	RHS FRAME 25	50 X 25 X 2 X 150	1	0.30
27	RHS FRAME 24	50 X 25 X 2 X 250	1	0.50
26	RHS FRAME 23	50 X 25 X 2 X 350	1	0.75
25	RHS FRAME 22	50 X 25 X 2 X 400	1	0.80
24	RHS FRAME 21	50 X 25 X 2 X 200	1	0.35
23	RHS FRAME 20	50 X 25 X 2 X 300	1	0.55
22	RHS FRAME 19	50 X 25 X 2 X 350	1	0.75
21	RHS FRAME 18	50 X 25 X 2 X 800	1	1.15
20	RHS FRAME 17	50 X 25 X 2 X 1000	1	1.90
19	RHS FRAME 16	50 X 25 X 2 X 1300	1	2.70
18	RHS FRAME 15	50 X 25 X 2 X 1650	1	3.50
17	RHS FRAME 14	50 X 25 X 2 X 2000	1	4.25
16	RHS FRAME 13	50 X 25 X 2 X 650	1	1.45
15	RHS FRAME 12	50 X 25 X 2 X 900	1	1.90
14	RHS FRAME 11	50 X 25 X 2 X 900	1	1.90
13	RHS FRAME 10	50 X 25 X 2 X 850	1	1.85
12	RHS FRAME 9	50 X 25 X 2 X 750	1	1.65
11	RHS FRAME 8	50 X 25 X 2 X 650	1	1.45
10	RHS FRAME 7	50 X 25 X 2 X 550	1	1.20
9	RHS FRAME 6	50 X 25 X 2 X 450	1	0.95
8	RHS FRAME 5	50 X 25 X 2 X 350	1	0.75
7	RHS FRAME 4	50 X 25 X 2 X 250	1	0.50
6	RHS FRAME 3	50 X 25 X 2 X 150	1	0.30
5	PLANK 3	100 X 25 X 1.6 X 850	1	2.25
4	PLANK 2	100 X 25 X 1.6 X 1000	1	2.80
3	PLANK 1	100 X 25 X 1.6 X 2300	1	6.95
2	RHS FRAME 2	50 X 25 X 2 X 1200	2	2.70
1	RHS FRAME 1	50 X 25 X 2 X 2500	2	5.60

This drawing is our property. It can't be reproduced or communicated without our written agreement. www.p2p.ind.in

APL APOLLO TUBES LTD.

DRAWING TITLE: GATE

SIZE: A0 DRAWING NUMBER: P2P APR 21-20 REV: 00

SCALE: As Indicated WEIGHT (kg): 0kg SHEET 1 OF 4

UNLESS OTHERWISE SPECIFIED DIMENSION ARE IN MM VIEWS: THIRD ANGLE PROJECTION

DRAWN BY: RR DATE: 06APR2021
 CHECKED BY: P2P Analysis & Solutions DATE: 06APR2021
 DESIGNED BY: P2P Analysis & Solutions DATE: 06APR2021

REV	DATE	DESCRIPTION
00	06APR2021	INITIAL REVISION

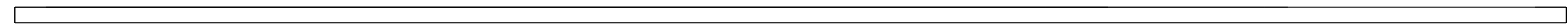

Top view
Scale: 1:5

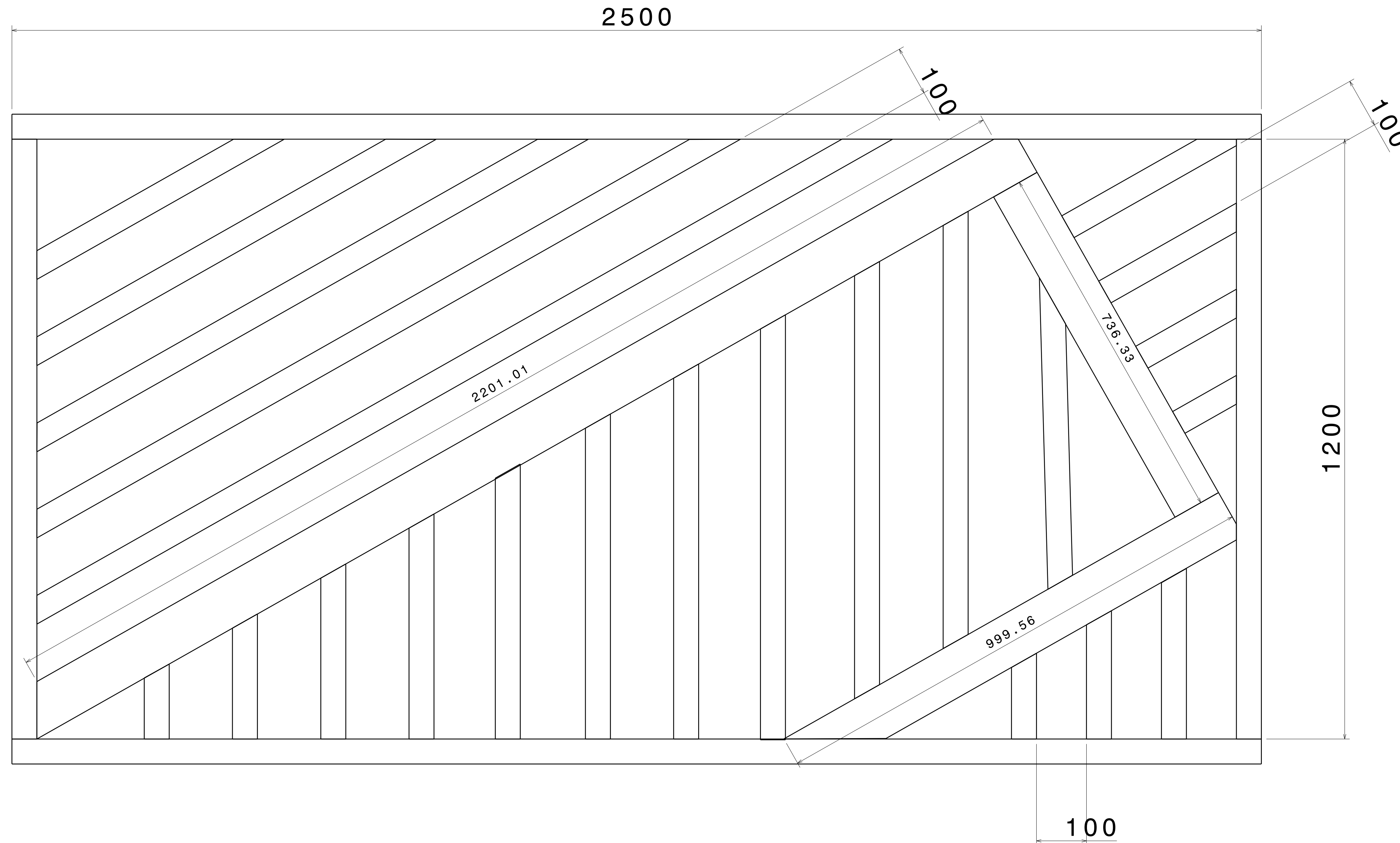

Front view
Scale: 1:5

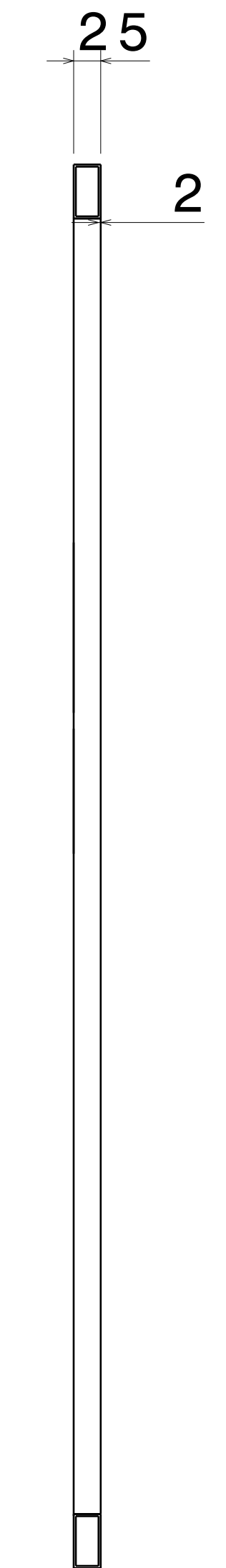

Right view
Scale: 1:5

UNLESS OTHERWISE SPECIFIED DIMENSION ARE IN MM
VIEWS: THIRD ANGLE PROJECTION

This drawing is our property. It can't be reproduced or communicated without our written agreement.
www.p2p.ind.in

DRAWN BY	DATE
SB	06APR2021
CHECKED BY	DATE
P2P Analysis & Solutions	06APR2021
DESIGNED BY	DATE
P2P Analysis & Solutions	06APR2021

APL APOLLO TUBES LTD.	
DRAWING TITLE	
GATE	
SIZE	DRAWING NUMBER
A0	P2P APR 21-20
SCALE	WEIGHT (kg)
NONE	XXX
REV	SHEET 2 OF 4
00	

REV	DATE	DESCRIPTION
00	06APR2021	INITIAL REVISION

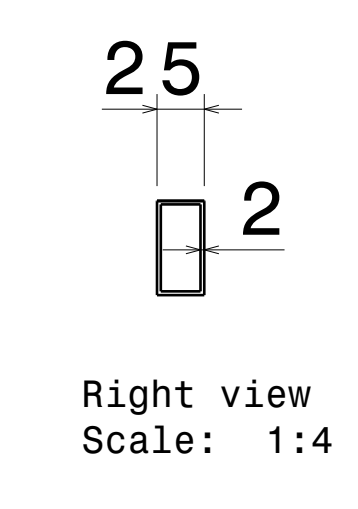
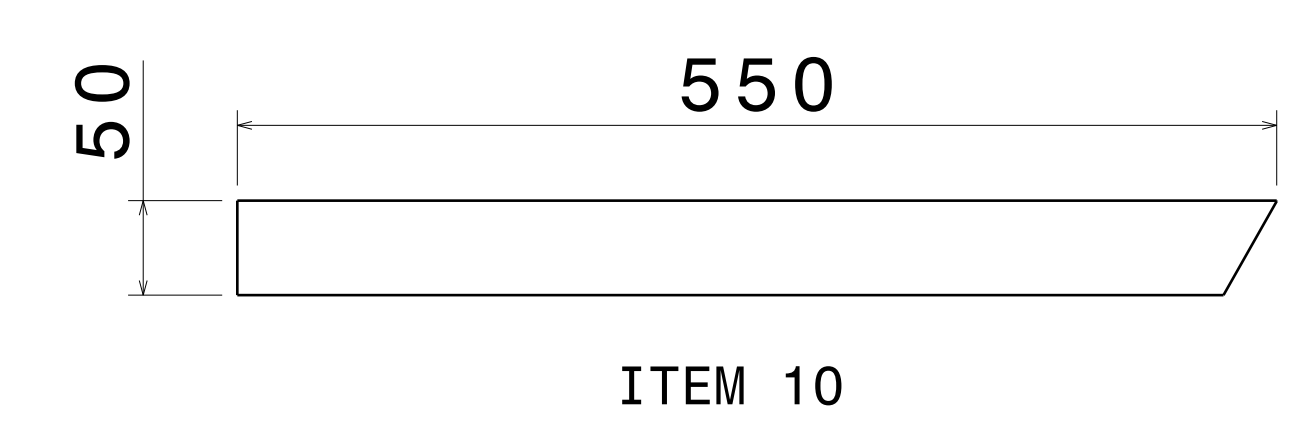
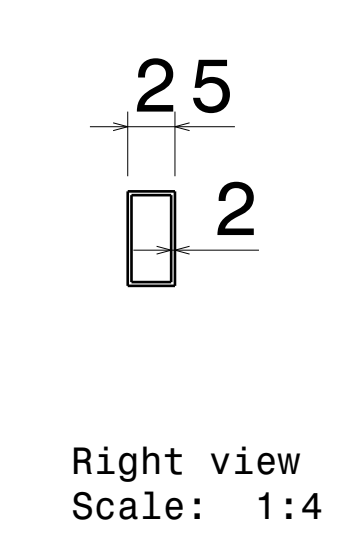
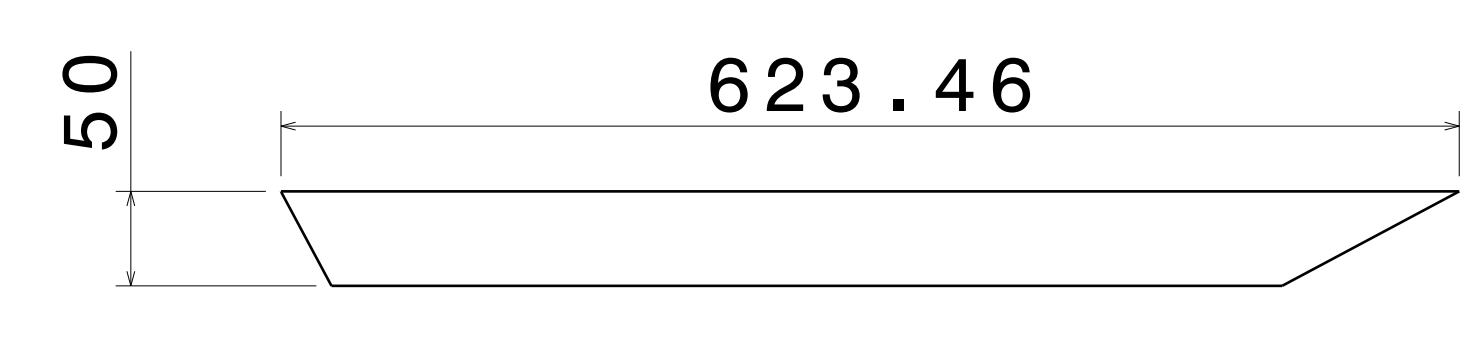
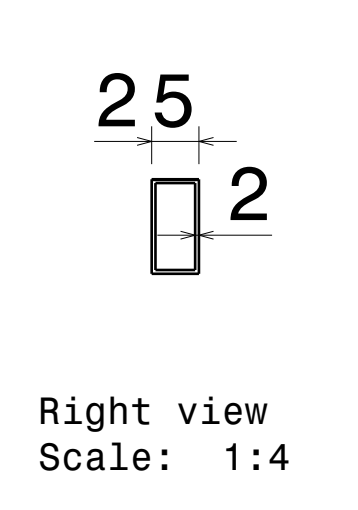
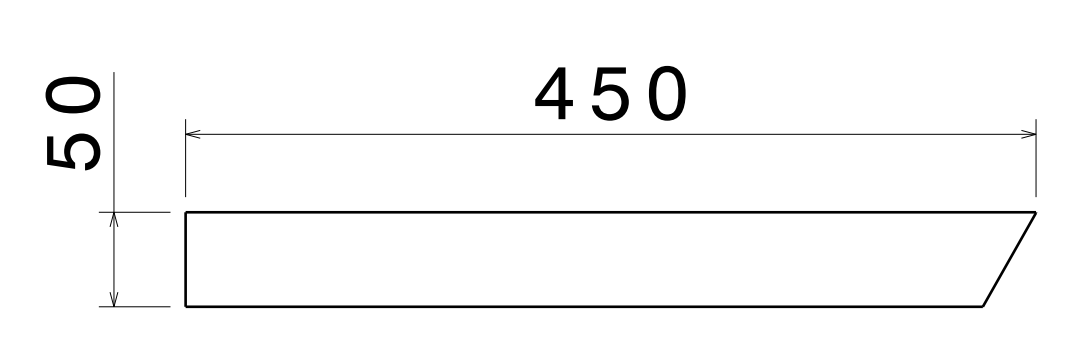
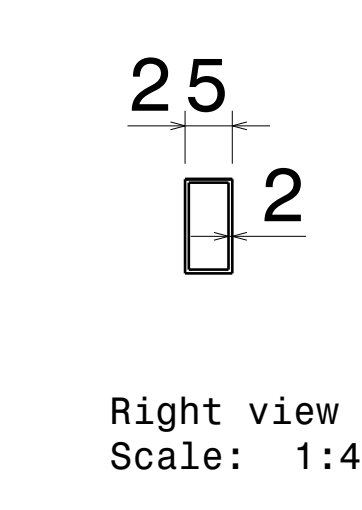
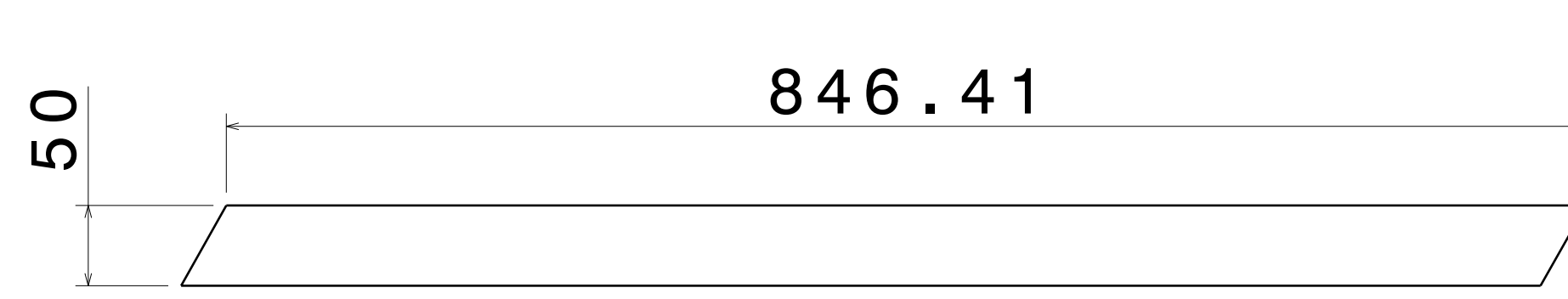
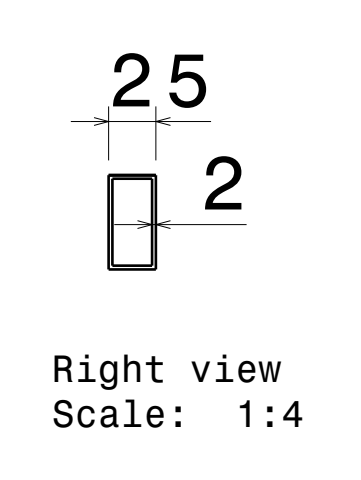
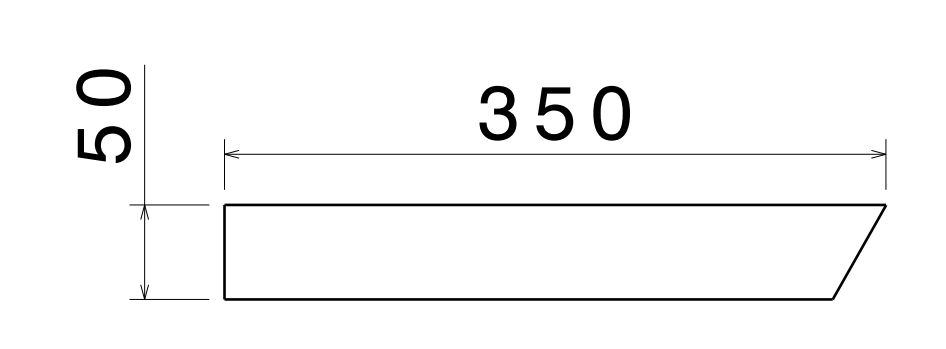
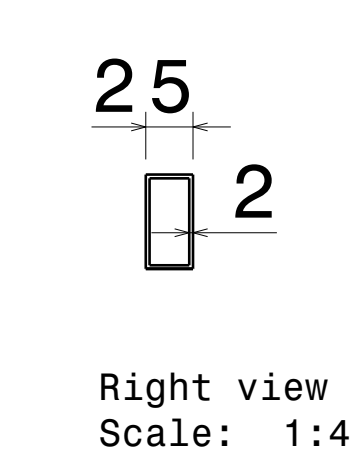
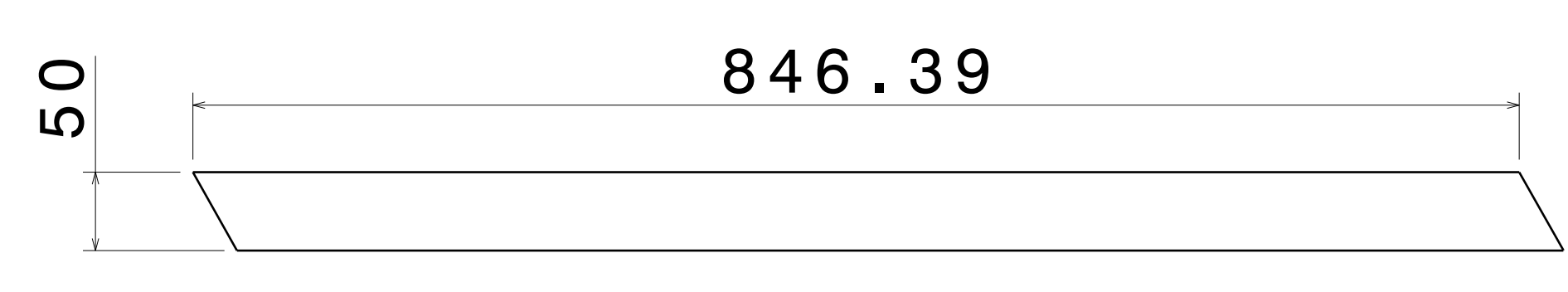
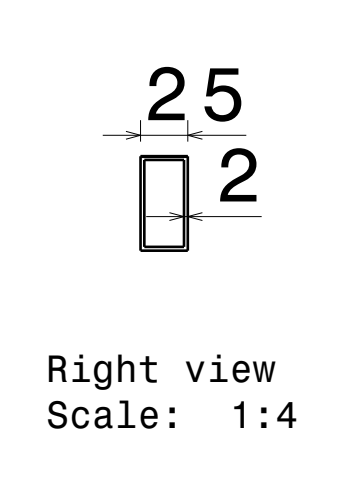
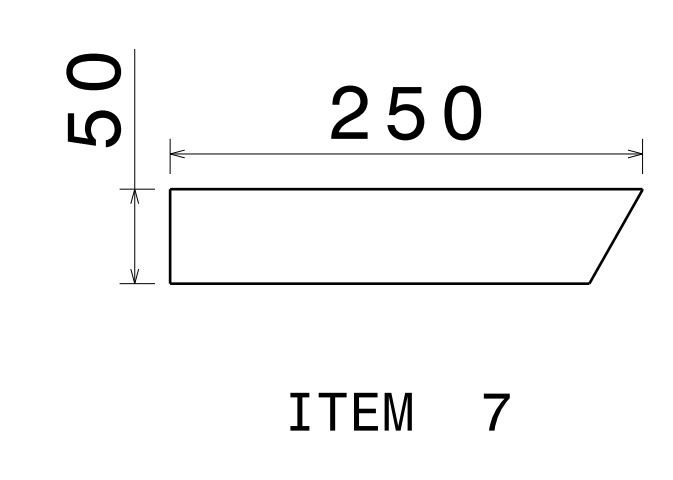
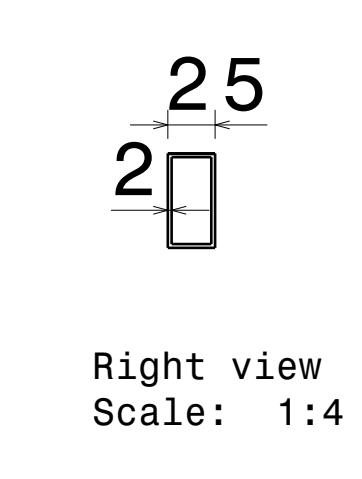
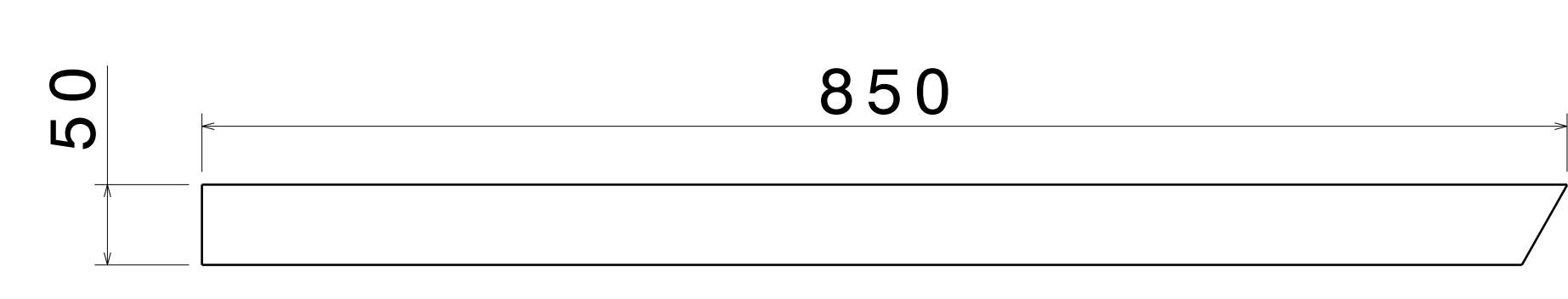
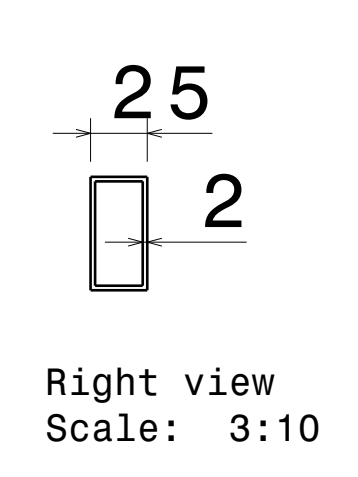
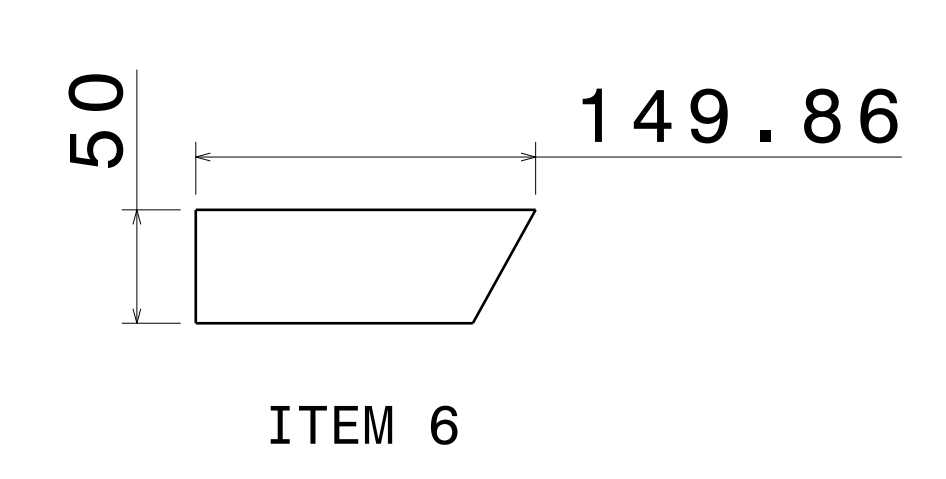
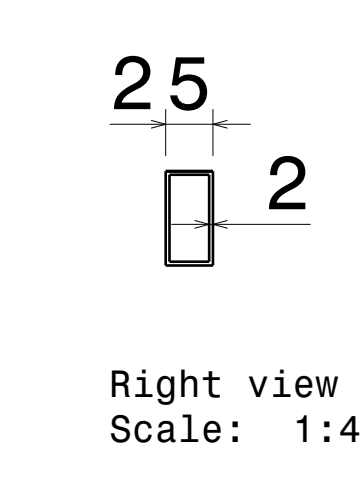
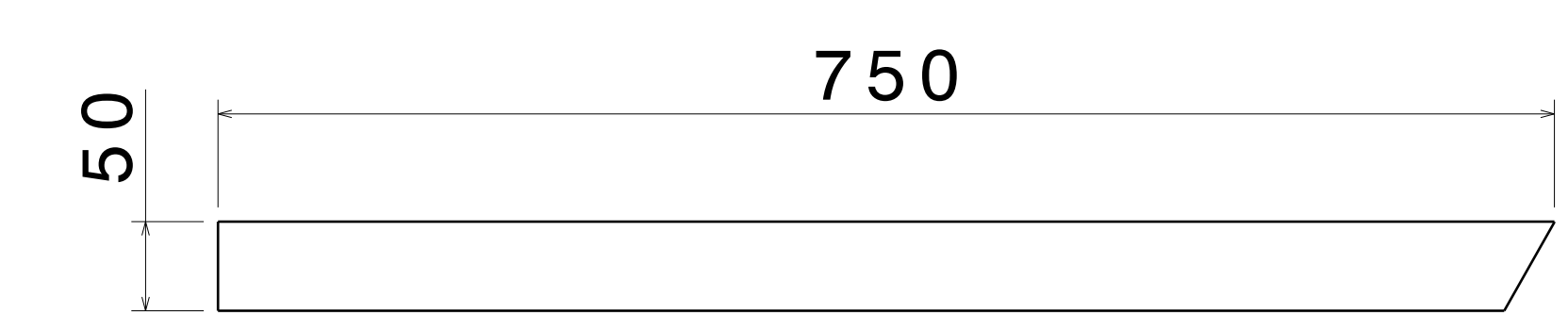
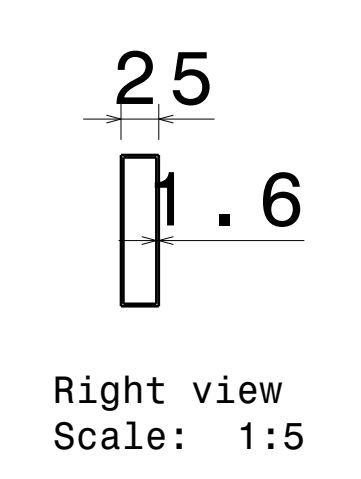
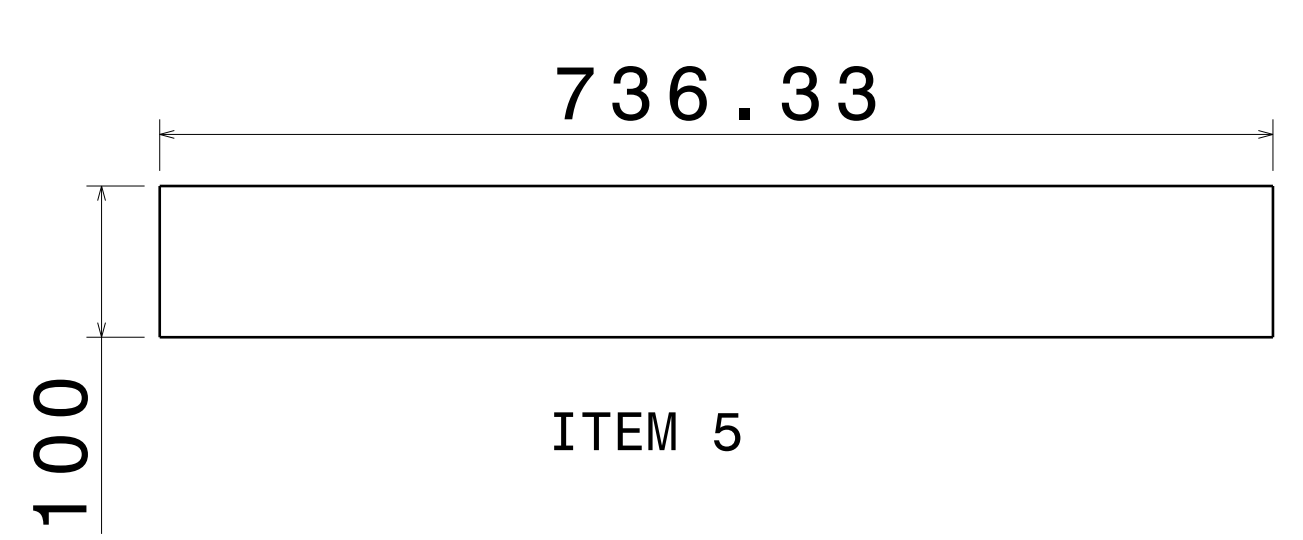
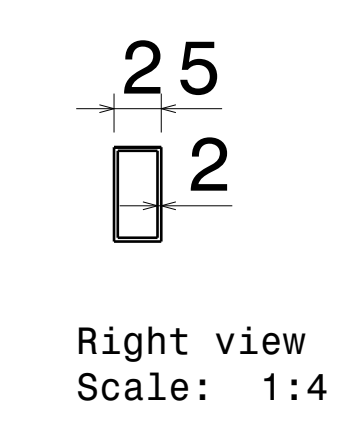
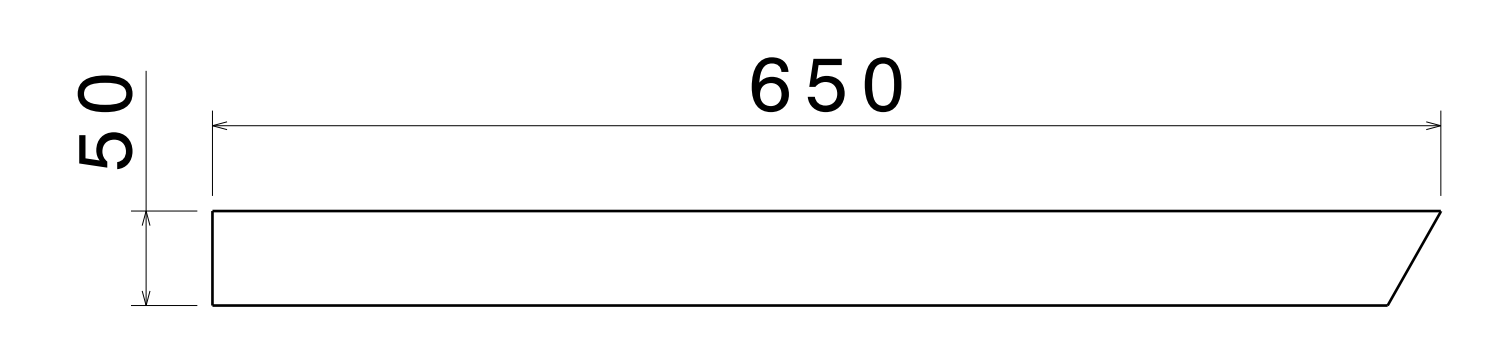
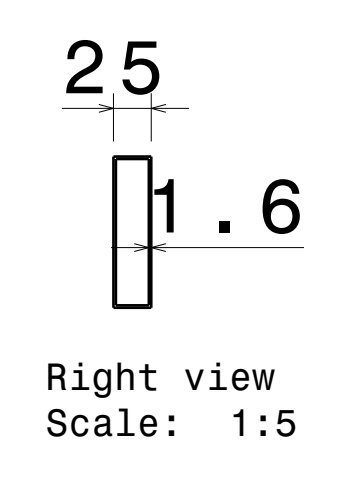
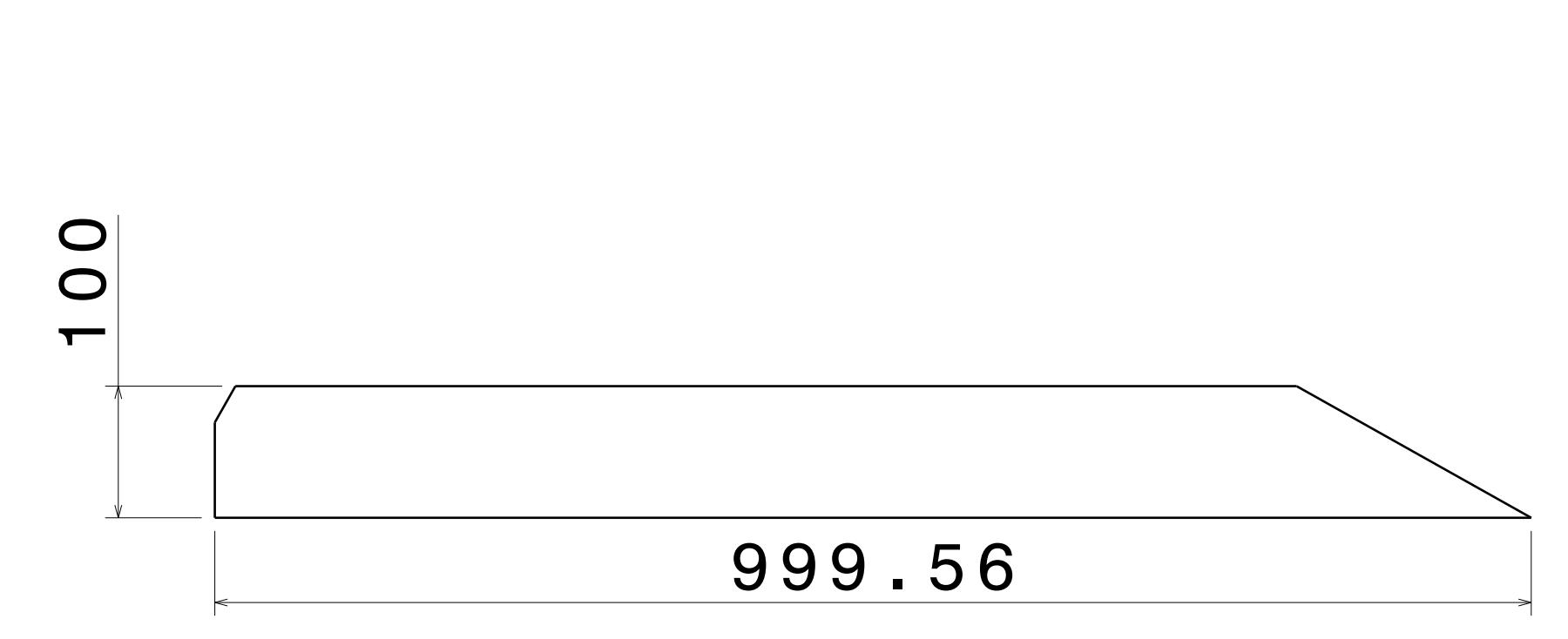
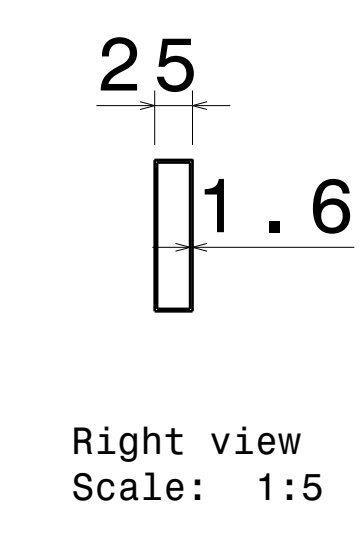
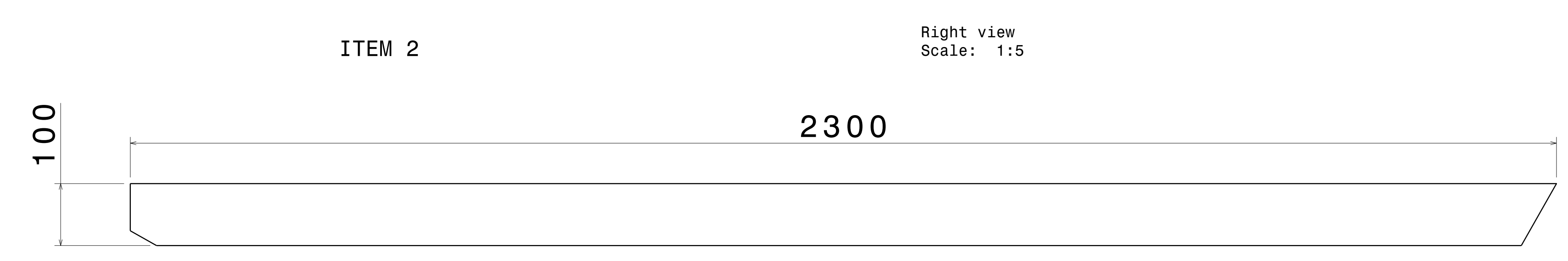
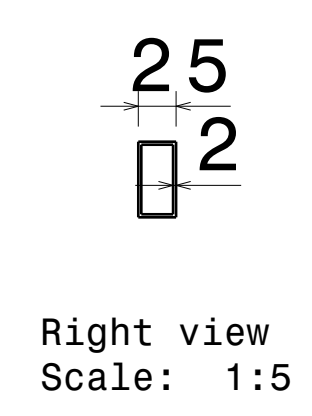
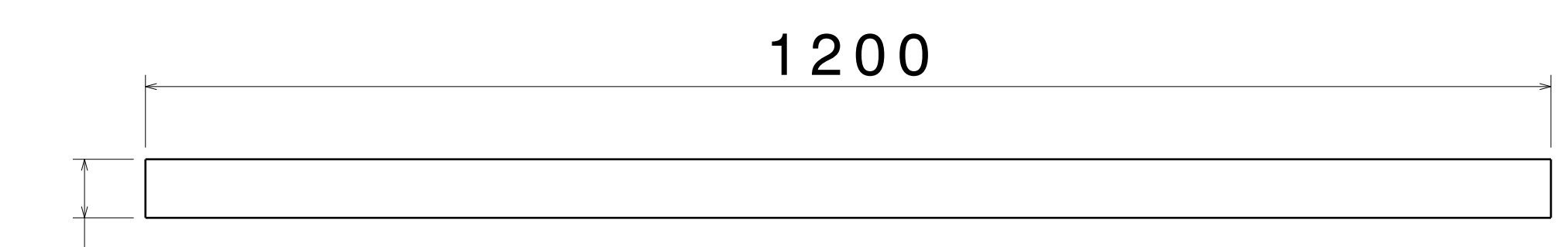
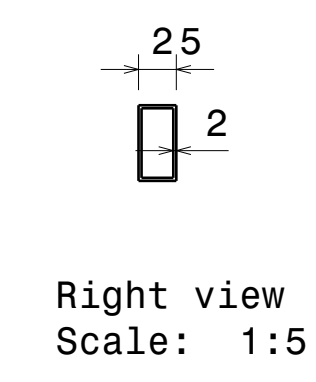
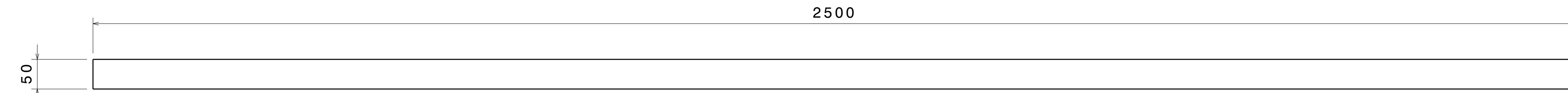

This drawing is our property. It can't be reproduced or communicated without our written agreement.
www.p2p.ind.in

APL APOLLO TUBES LTD. 
DRAWING TITLE

DRAWN BY: SB
CHECKED BY: P2P Analysis & Solutions
DESIGNED BY: P2P Analysis & Solutions

DATE: 06APR2021
DATE: 06APR2021
DATE: 06APR2021
SIZE: A0
DRAWING NUMBER: P2P APR 21-20
SCALE: NONE
WEIGHT (kg): XXX
REV: 00
SHEET 3 OF 4

UNLESS OTHERWISE SPECIFIED DIMENSION ARE IN MM
THIRD ANGLE PROJECTION

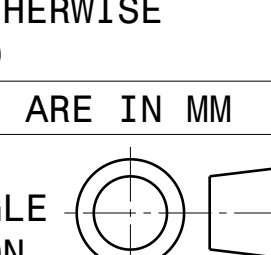

REV	DATE	DESCRIPTION
00	06APR2021	INITIAL REVISION

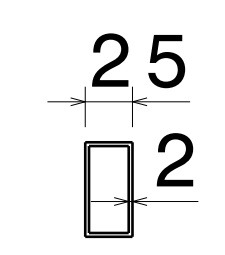
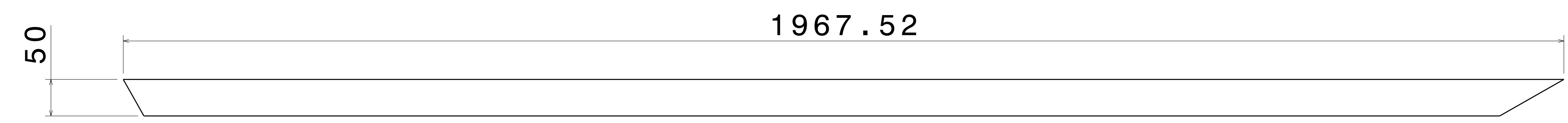

Right view
Scale: 1:4

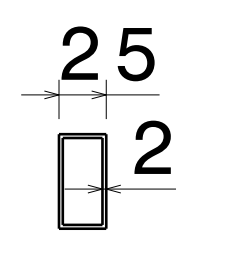
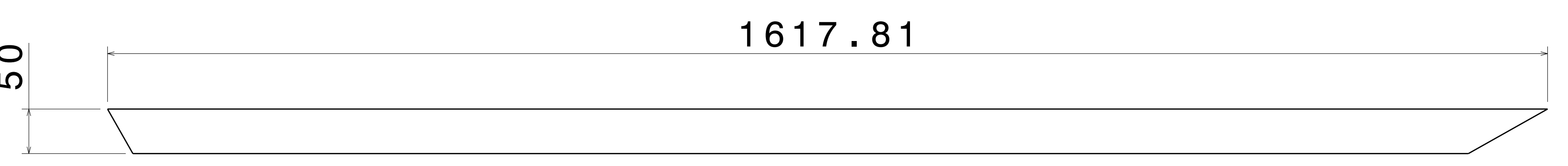

Right view
Scale: 1:4

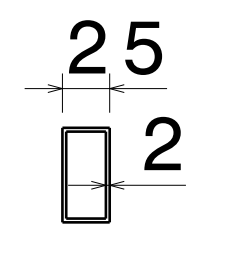
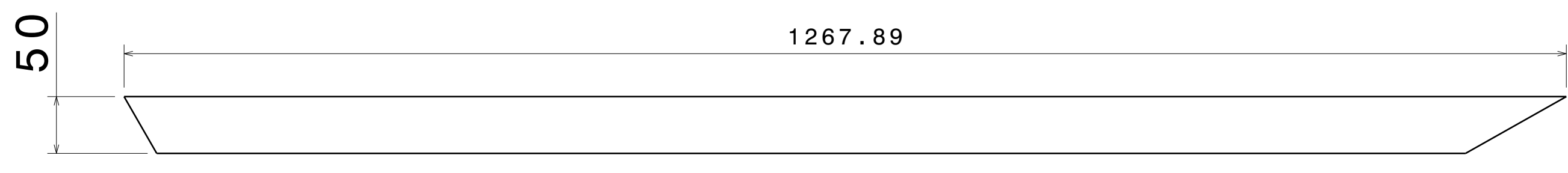

Right view
Scale: 1:4

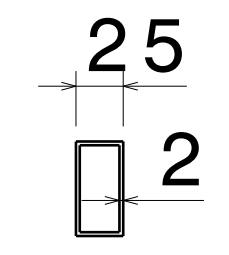
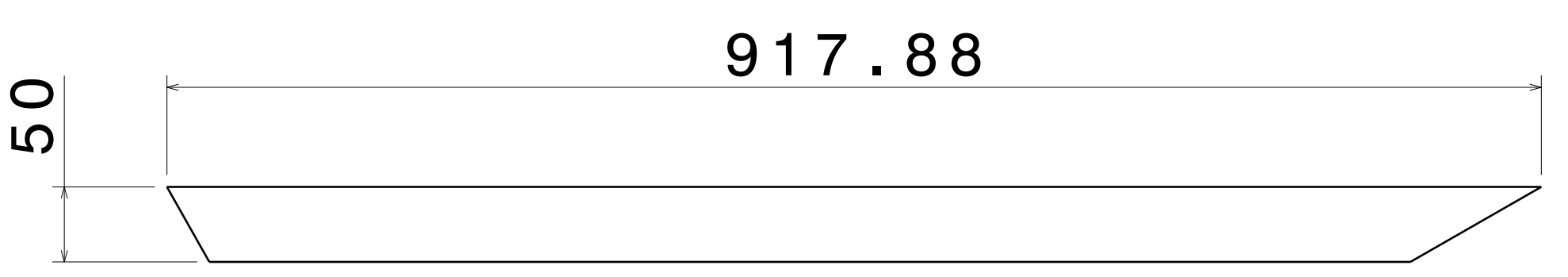

Right view
Scale: 1:4

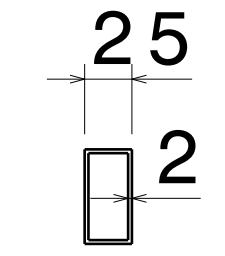
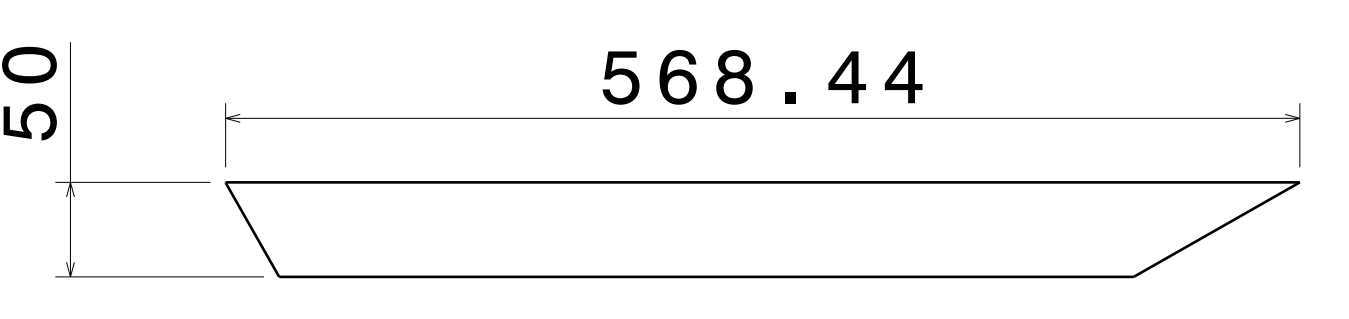

Right view
Scale: 1:4

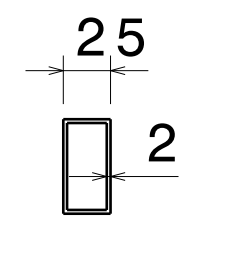
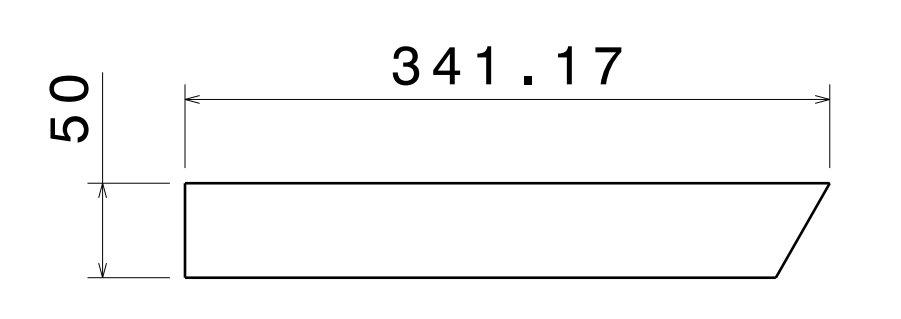

Right view
Scale: 1:4

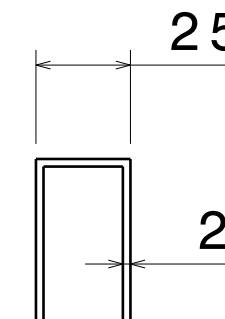
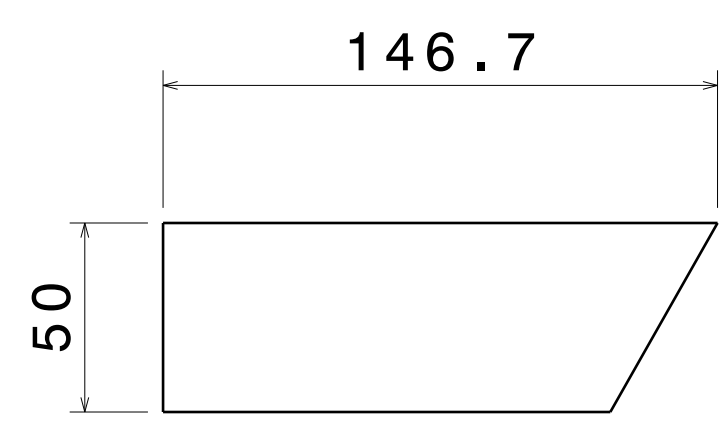

Right view
Scale: 1:2

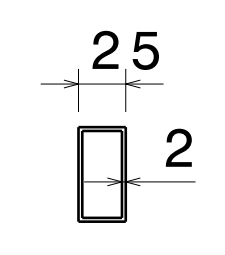
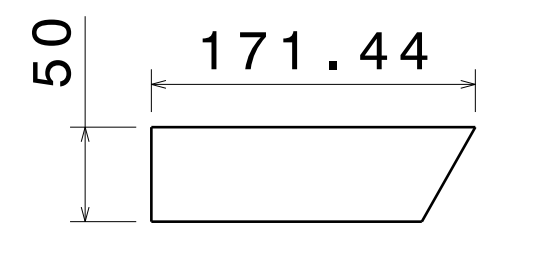

Right view
Scale: 1:4

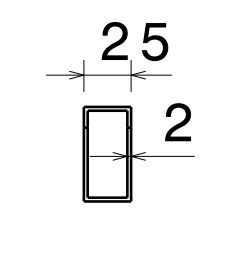
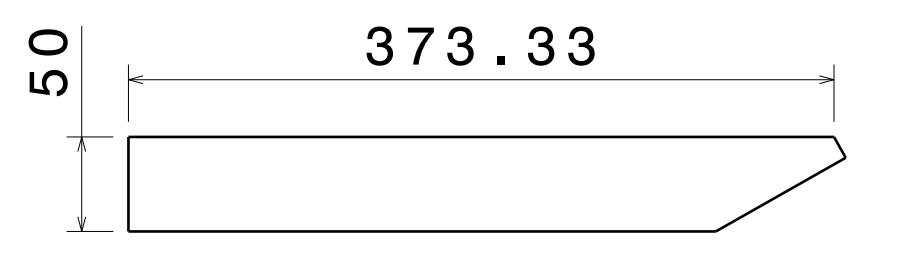

Right view
Scale: 1:4

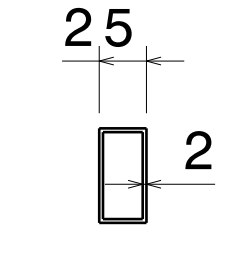
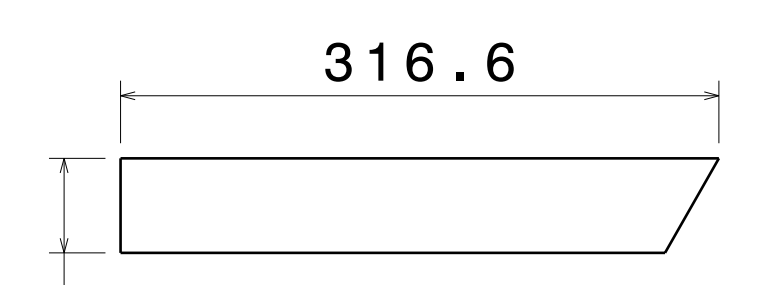

Right view
Scale: 1:4

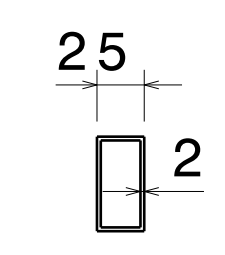
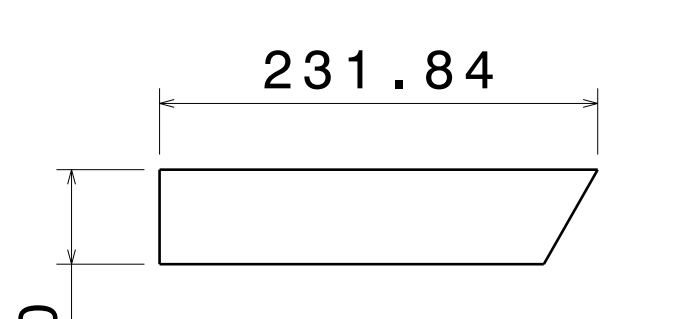

Right view
Scale: 1:4

UNLESS OTHERWISE SPECIFIED DIMENSION ARE IN MM VIEWS: THIRD ANGLE PROJECTION

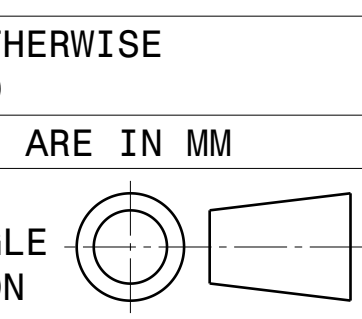

This drawing is our property. It can't be reproduced or communicated without our written agreement. www.p2p.ind.in

DRAWN BY	SB	DATE	06APR2021
CHECKED BY	P2P Analysis & Solutions	DATE	06APR2021
DESIGNED BY	P2P Analysis & Solutions	DATE	06APR2021

APL APOLLO TUBES LTD.	
DRAWING TITLE	
GATE	
SIZE	A0
DRAWING NUMBER	P2P APR 21-20
REV	00
SCALE	NONE
WEIGHT (kg)	XXX
SHEET 4 OF 4	