

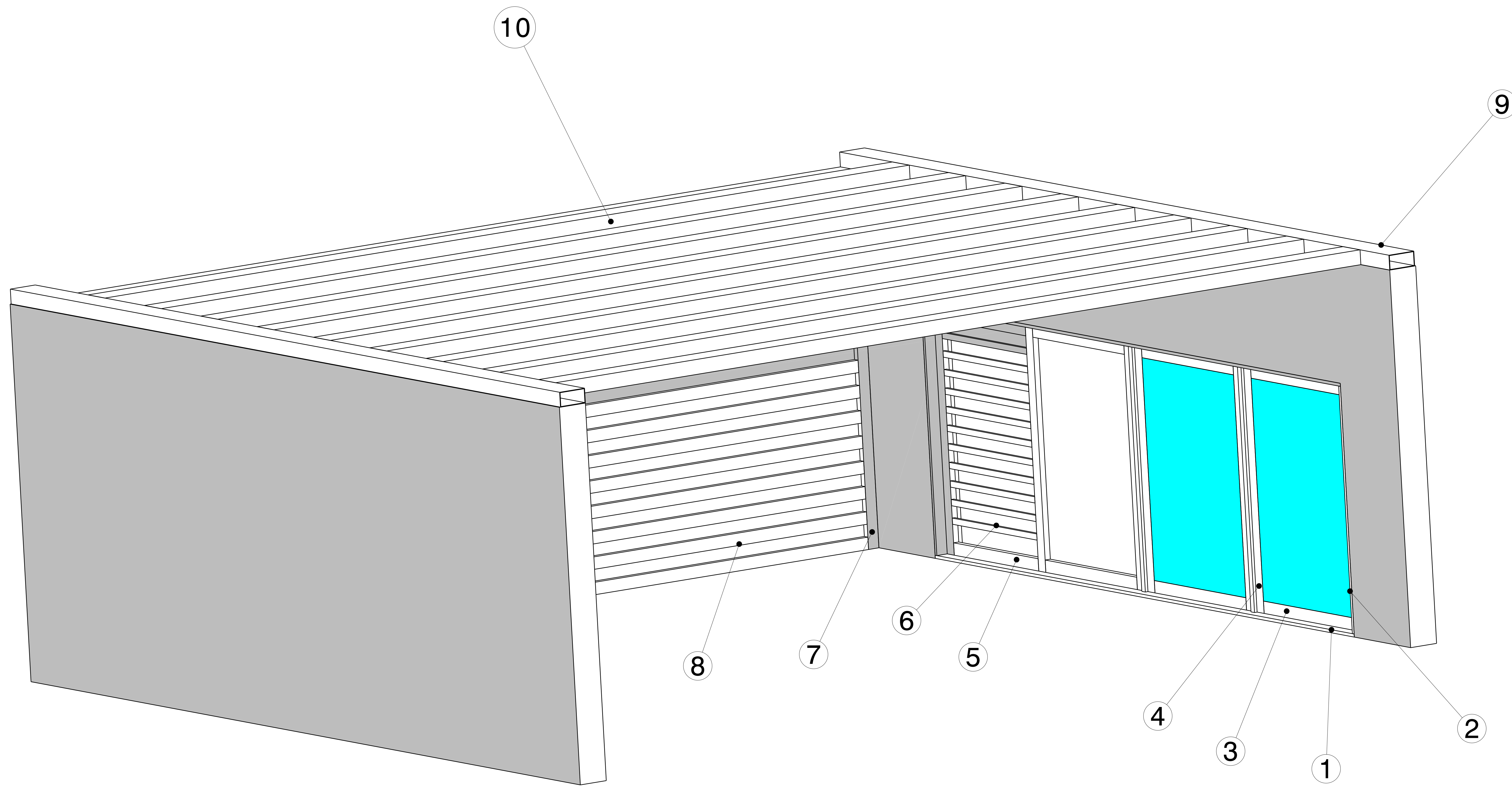

REV/DATE	DESCRIPTION
00 / 5DEC2020	INITIAL REVISION

- NOTES:
- (⊥) ALL VERTICAL SUPPORTS ARE PERPENDICULAR.
 - FLATNESS OF .5MM IS APPLIED BY DEFAULT.
 - ⊲ WELD BEAD OF 2MM RADIUS IS FOLLOWED.
 - ▽▽ SURFACE FINISH MEDIUM TO SMOOTH IS USED.
 - ALL TUBES ARE AS PER APL APOLLO STANDARD. CHANGES MAY EFFECT THE LOAD CAPACITY.
 - ALL HORIZONTAL AND VERTICAL TUBES ARE PERPENDICULAR TO EACH OTHER WITH ±1 DEG.
 - FINE WELDING IS REQUIRED AS PER MENTIONED DETAILS AND FINISHING.
 - HIGHER CURRENT WELDING MAY AFFECT THE BRITTLNESS OF MATERIAL WHICH LATER MAY RAISE TO WEAKENING OF STRUCTURE.
 - FABRICATORS ARE ALLOWED TO USE FITTINGS/FRAMES/SUPPORTS AS NEEDED AND THE SAME MUST BE COMMUNICATED BACK TO ENGINEERING TEAM.
 - BOP COMPONENT WEIGHTS ARE FOR REFERENCE ONLY AND SUBJECTED TO CHANGE PER PURCHASED COMPONENTS.



ISOMETRIC VIEW
SCALE:1:20

ITEM NO.	PART NUMBER	DESCRIPTION	QTY.	Wt(Kg)/Each
10	RHS FRAME 8	240 X 120 X 4 X 7750	9	171.54
9	RHS FRAME 7	240 X 120 X 4 X 7800	2	172.64
8	RHS FRAME 6	100 X 50 X 3.6 X 7550	11	61.01
7	RHS FRAME 5	100 X 50 X 3.6 X 2550	2	20.61
6	RHS FRAME 4	50 X 25 X 2 X 1200	11	2.68
5	RHS FRAME 3	100 X 50 X 3.6 X 1200	2	9.7
4	RHS FRAME 2	100 X 50 X 3.6 X 2000	9	16.16
3	RHS FRAME 1	100 X 50 X 3.6 X 1300	6	10.51
2	RHS PLANK 2	250 X 25 X 2 X 2000	2	17.04
1	RHS PLANK 1	250 X 25 X 2 X 5950	2	50.7

This drawing is our property. It can't be reproduced or communicated without our written agreement.		APL APOLLO TUBES LTD. 	
DRAWN BY VM		DATE 5DEC2020	
CHECKED BY P2P Analysis & Solutions		DATE 5DEC2020	
DESIGNED BY P2P Analysis & Solutions		DATE 5DEC2020	
DRAWING TITLE DEC 20 10		REV 00	
SIZE A0		DRAWING NUMBER P2P DEC 20 10	
SCALE As Indicated		WEIGHT(kg) 0kg	
		SHEET 1 OF 3	

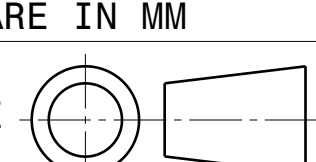
UNLESS OTHERWISE SPECIFIED DIMENSION ARE IN MM VIEWS: THIRD ANGLE PROJECTION 

REV	DATE	DESCRIPTION
00	5DEC2020	INITIAL REVISION

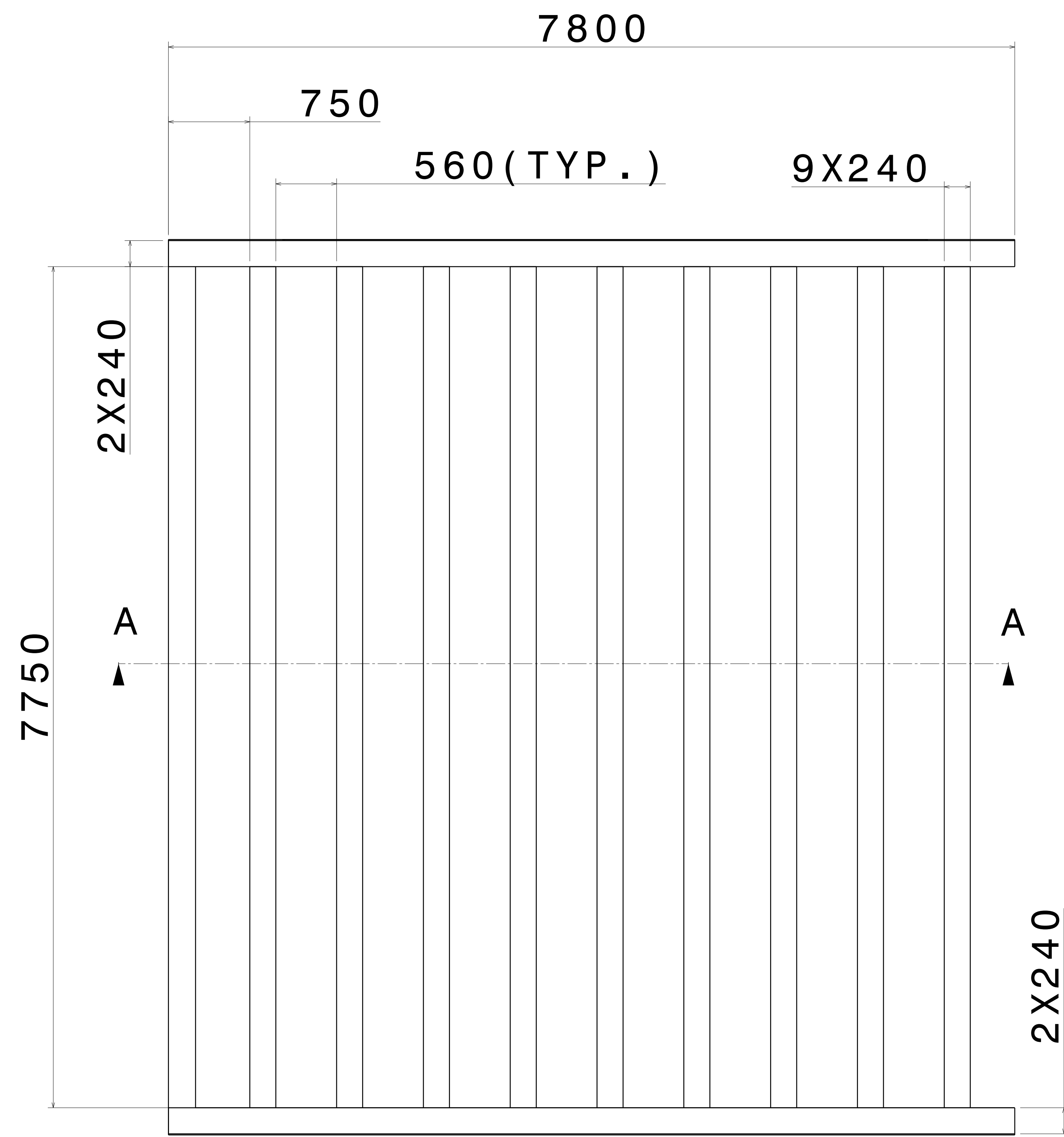

FRONT VIEW
SCALE: 1:25

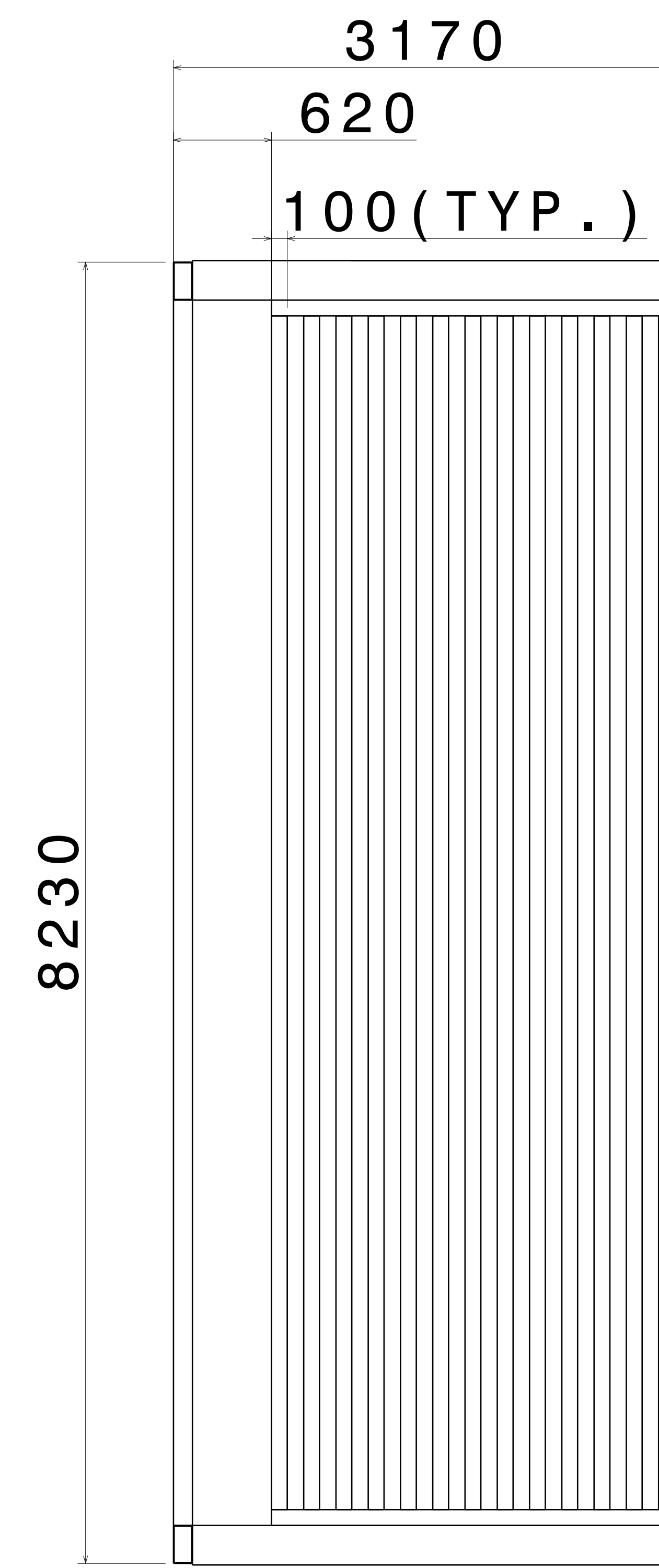

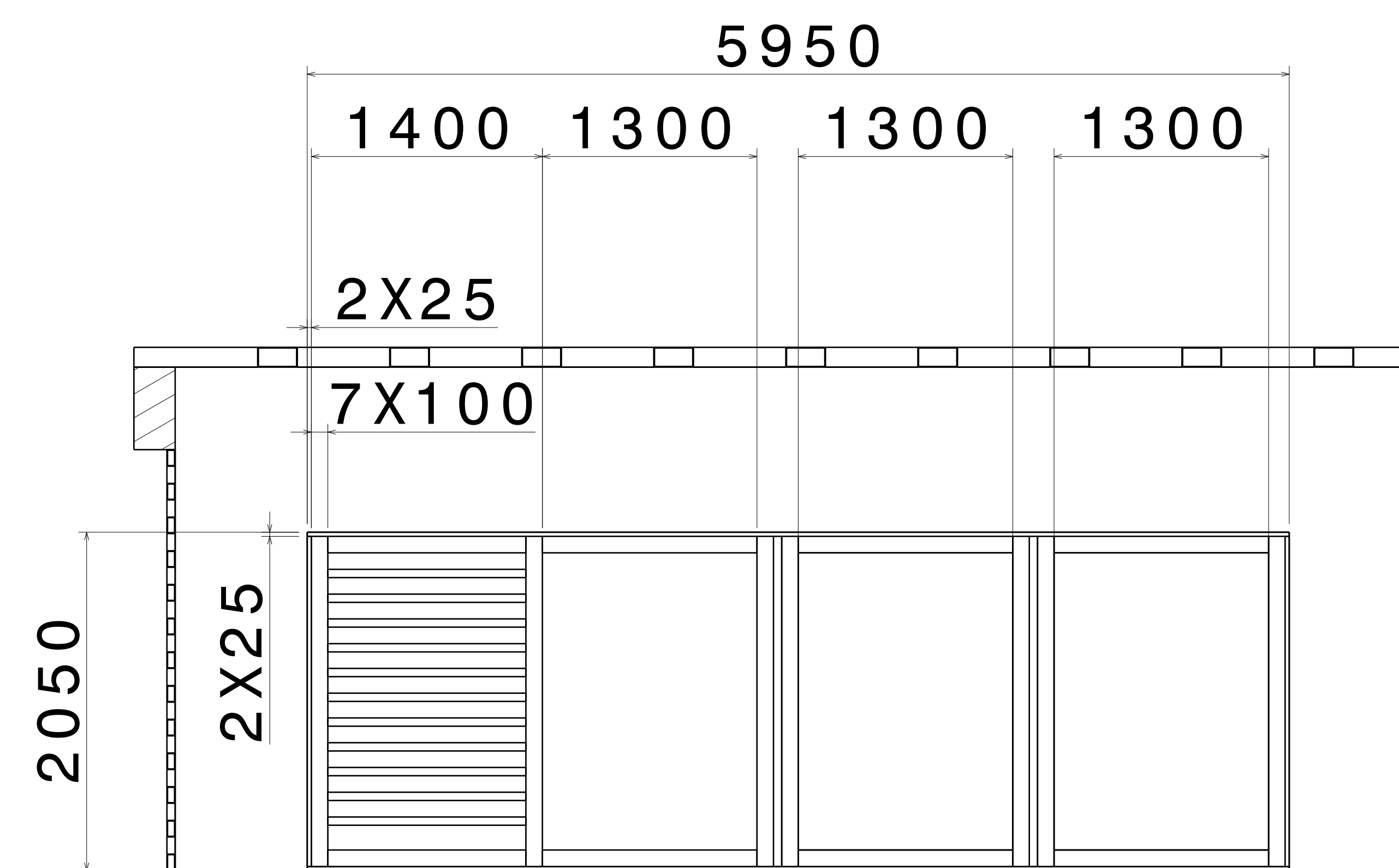

RIGHT VIEW
SCALE: 1:25

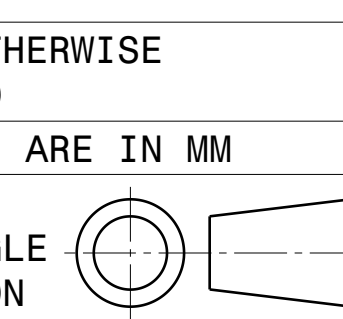

SECTION VIEW A-A
SCALE: 1:25

UNLESS OTHERWISE SPECIFIED DIMENSION ARE IN MM
VIEWS: THIRD ANGLE PROJECTION



This drawing is our property. It can't be reproduced or communicated without our written agreement.		APL APOLLO TUBES LTD. 	
DRAWN BY SB		DATE 5DEC2020	
CHECKED BY P2P Analysis & Solutions		DATE 5DEC2020	
DESIGNED BY P2P Analysis & Solutions		DATE 5DEC2020	
SIZE A0	DRAWING NUMBER P2P DEC 20 10		REV 00
SCALE NONE	WEIGHT (kg)	XXX	SHEET 2 OF 3

REV	DATE	DESCRIPTION
00	5DEC2020	INITIAL REVISION

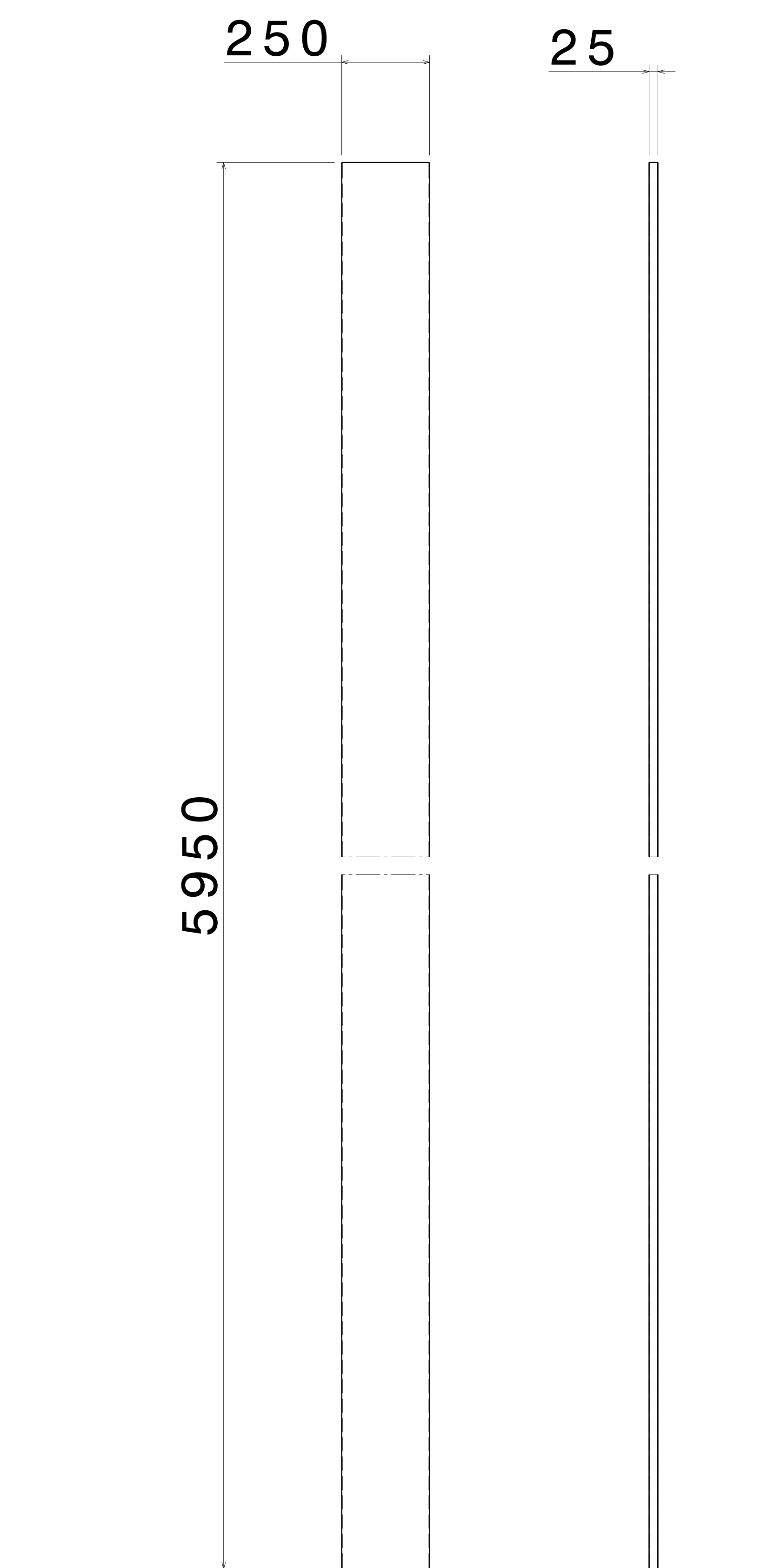

FRONT VIEW RIGHT VIEW
SCALE: 1:10 SCALE: 1:10
ITEM 1, RHS PLANK 1
THICKNESS - 2.0 MM

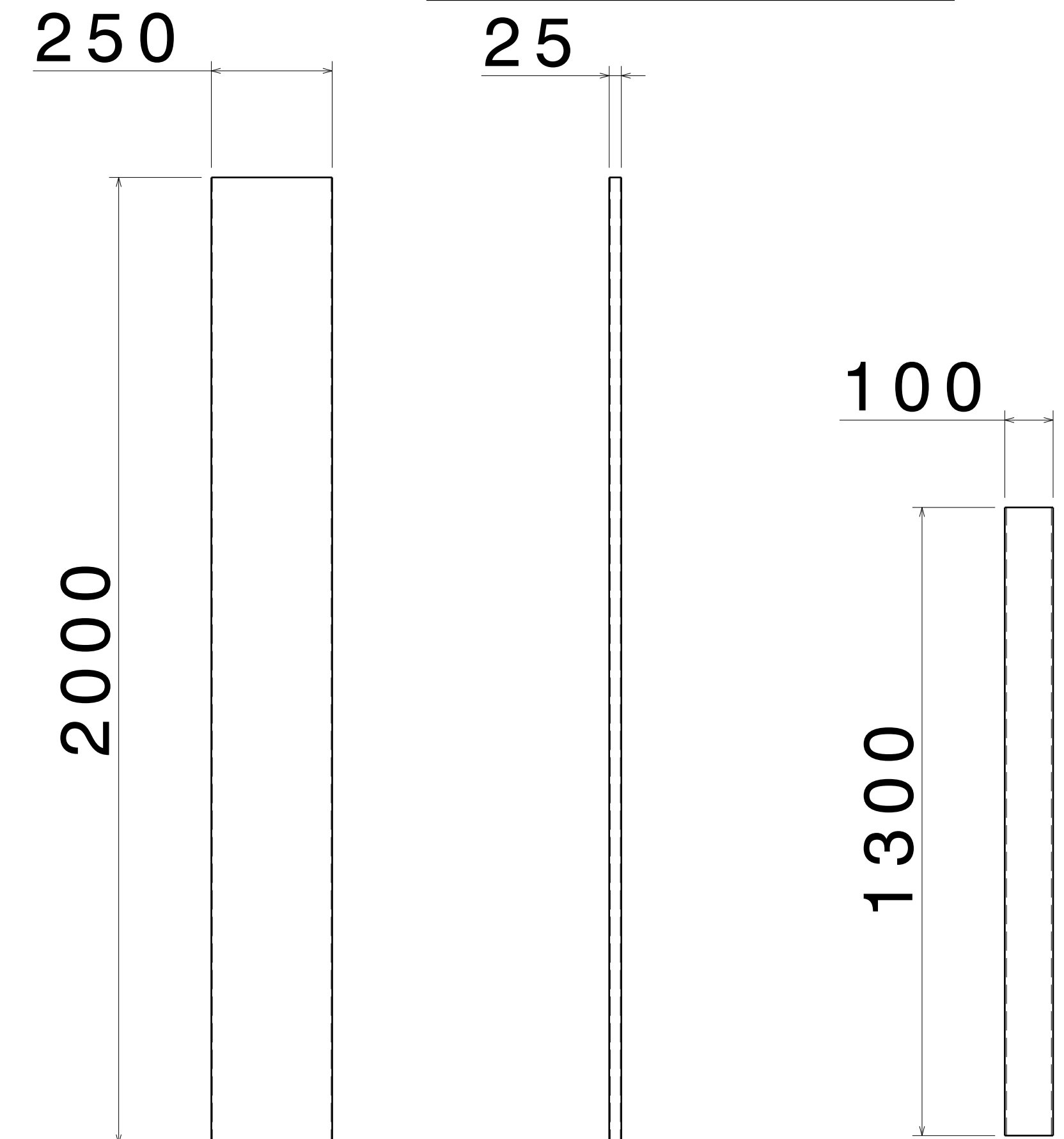

FRONT VIEW RIGHT VIEW
SCALE: 1:10 SCALE: 1:10
ITEM 2, RHS PLANK 2
THICKNESS - 2.0 MM

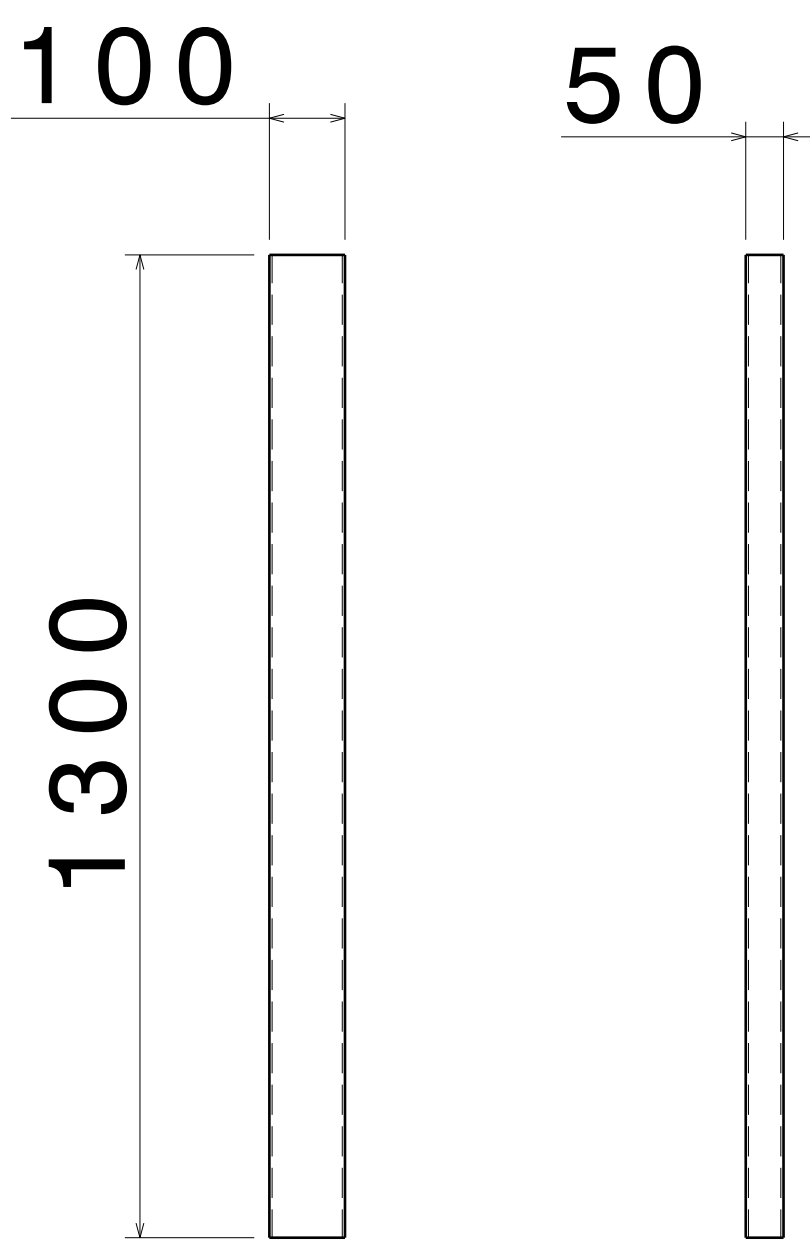

FRONT VIEW RIGHT VIEW
SCALE: 1:10 SCALE: 1:10
ITEM 3, RHS FRAME 1
THICKNESS - 3.6MM

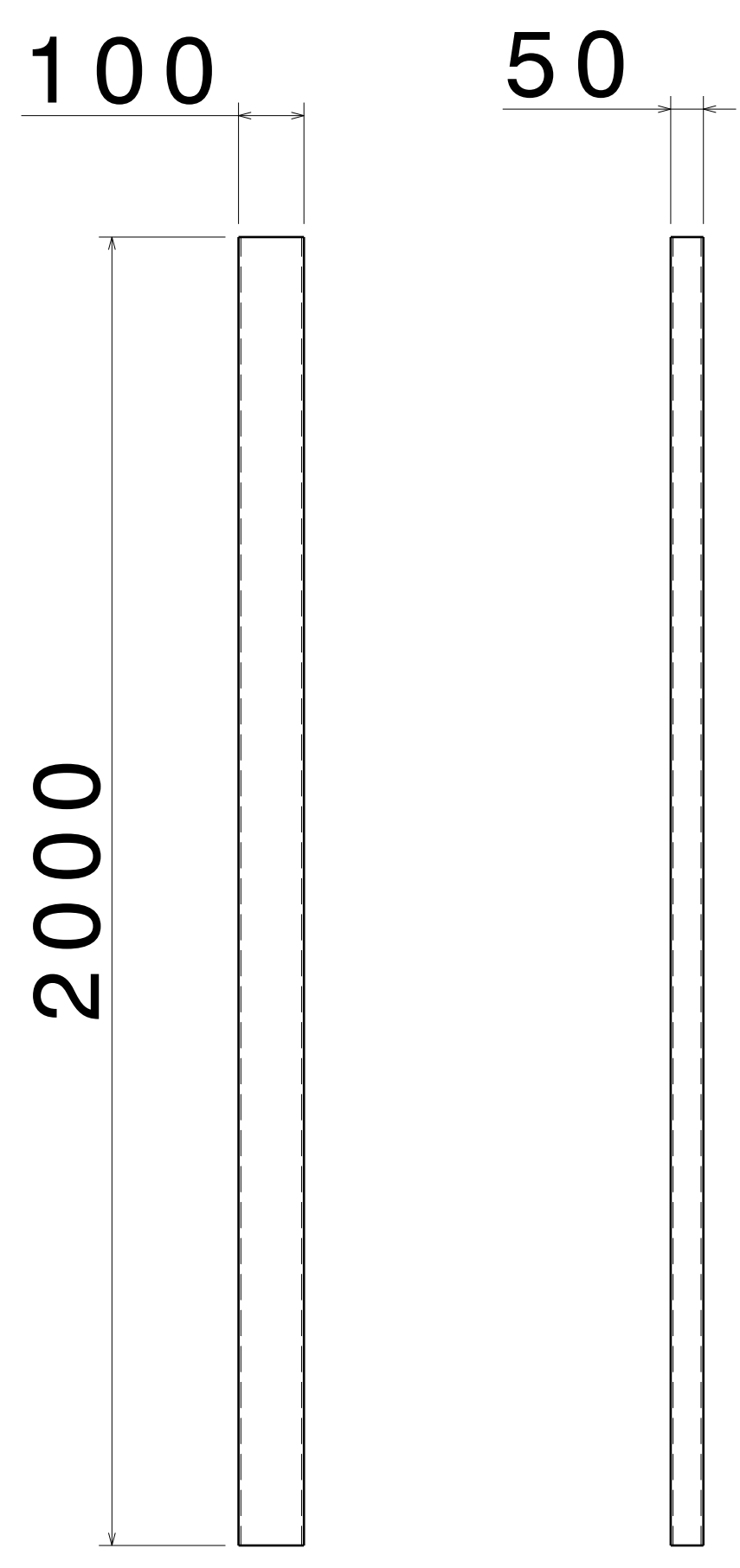

FRONT VIEW RIGHT VIEW
SCALE: 1:10 SCALE: 1:10
ITEM 4, RHS FRAME 2
THICKNESS - 3.6MM

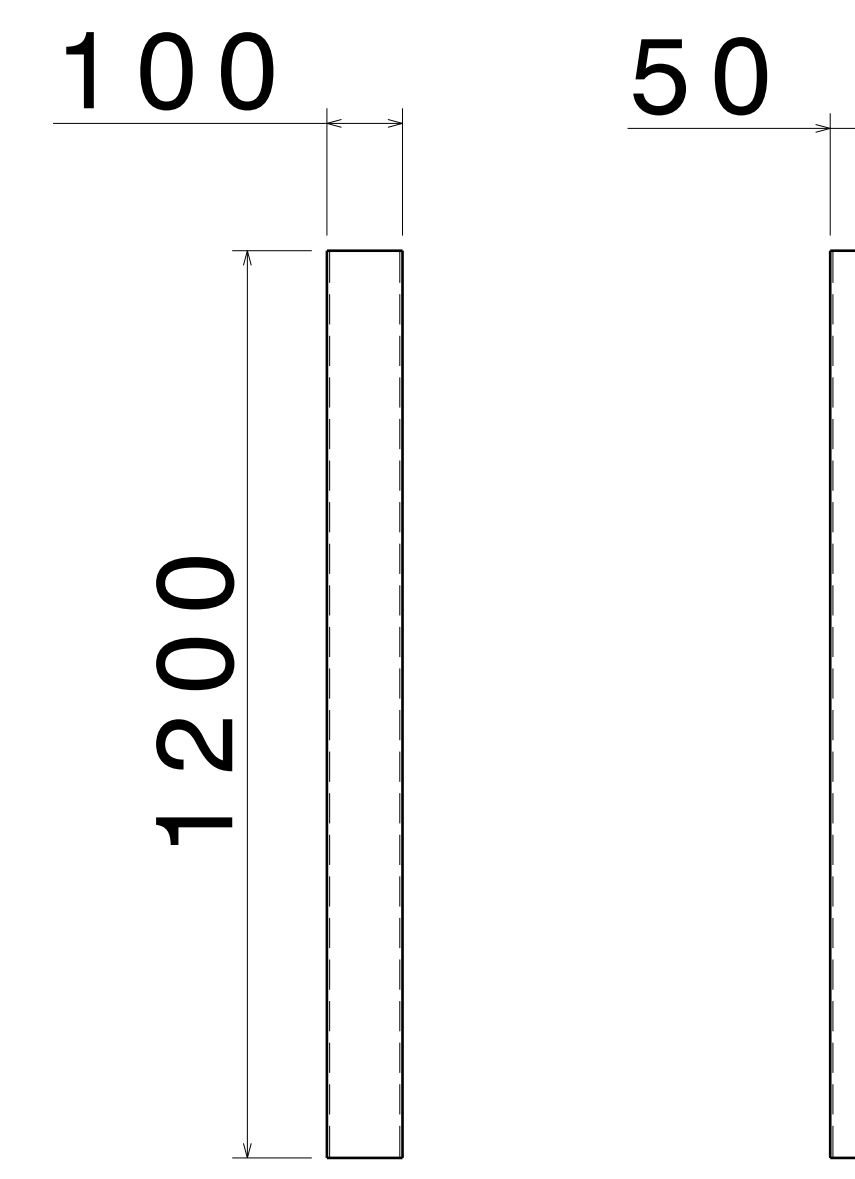

FRONT VIEW RIGHT VIEW
SCALE: 1:10 SCALE: 1:10
ITEM 5, RHS FRAME 3
THICKNESS - 3.6MM

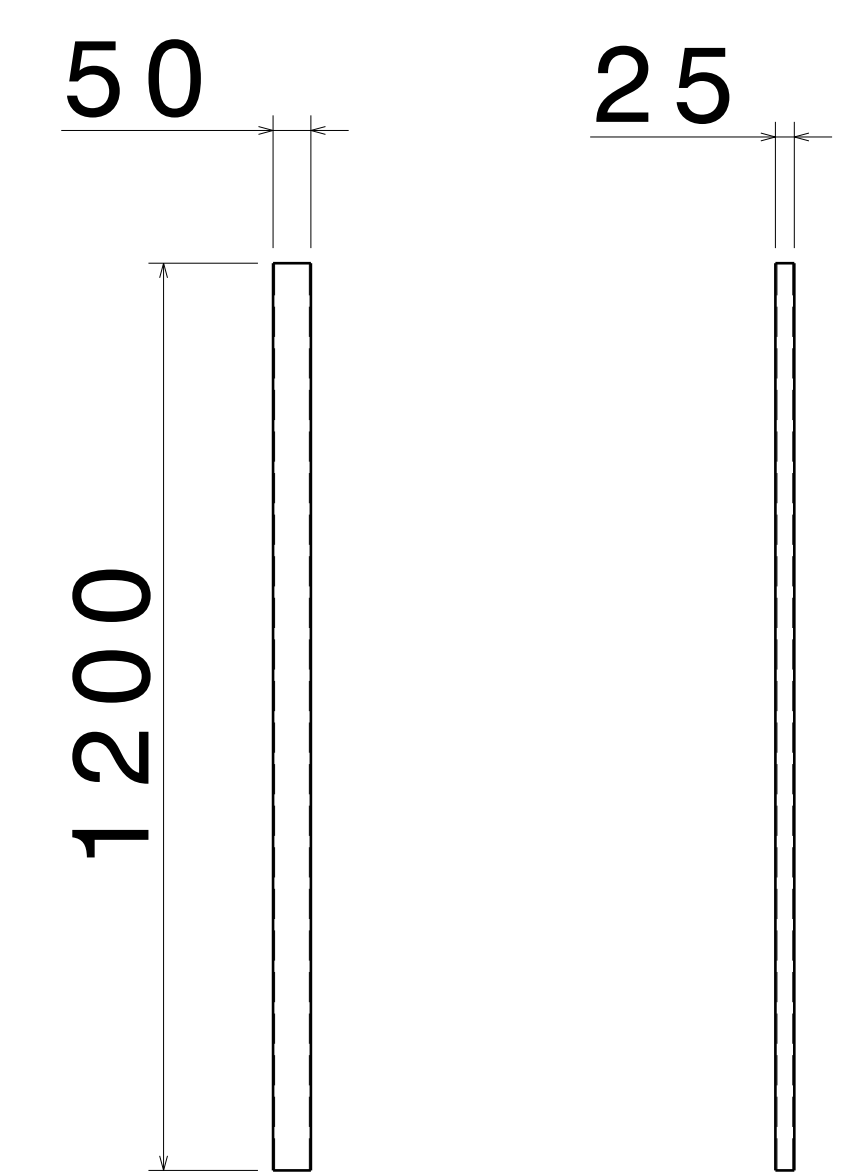

FRONT VIEW RIGHT VIEW
SCALE: 1:10 SCALE: 1:10
ITEM 6, RHS FRAME 4
THICKNESS - 2.0MM

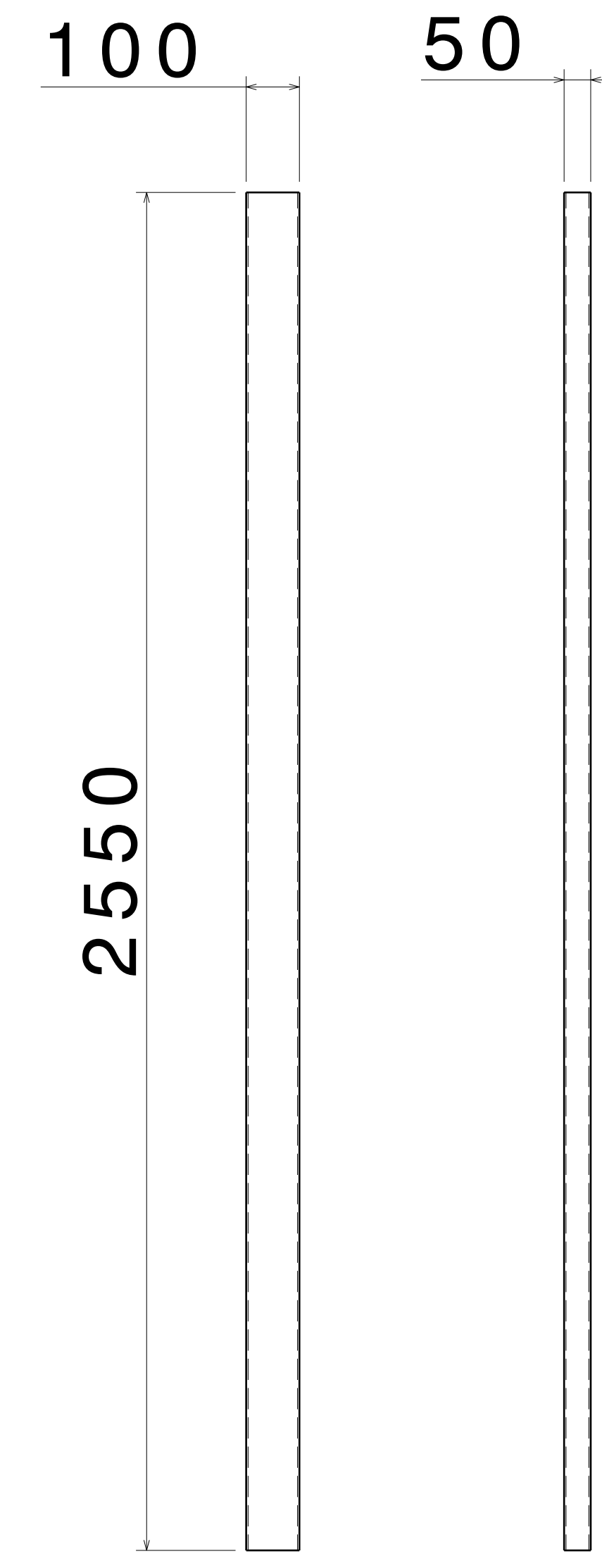

FRONT VIEW RIGHT VIEW
SCALE: 1:10 SCALE: 1:10
ITEM 7, RHS FRAME 5
THICKNESS - 3.6MM

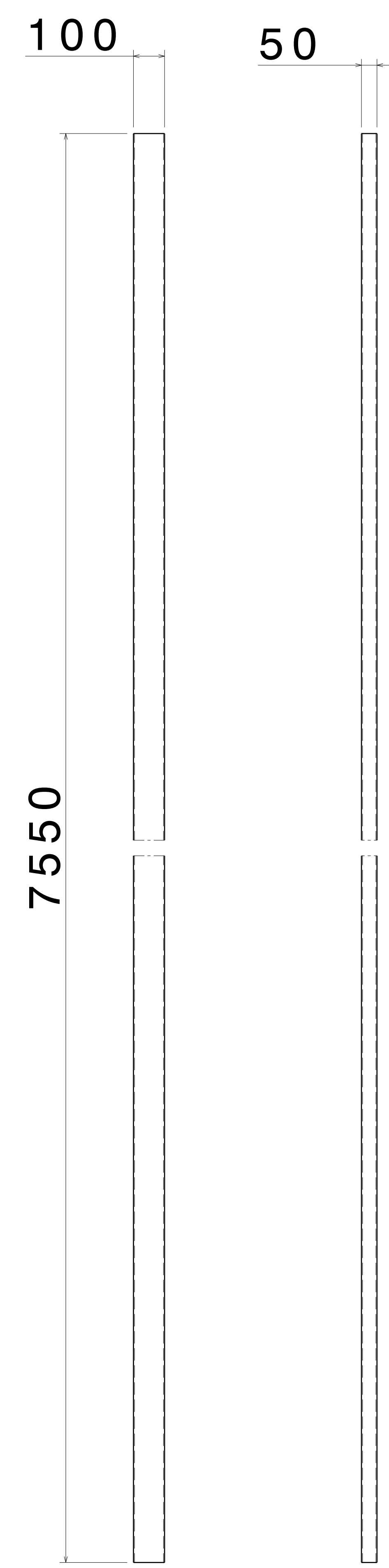

FRONT VIEW RIGHT VIEW
SCALE: 1:10 SCALE: 1:10
ITEM 8, RHS FRAME 6
THICKNESS - 3.6MM

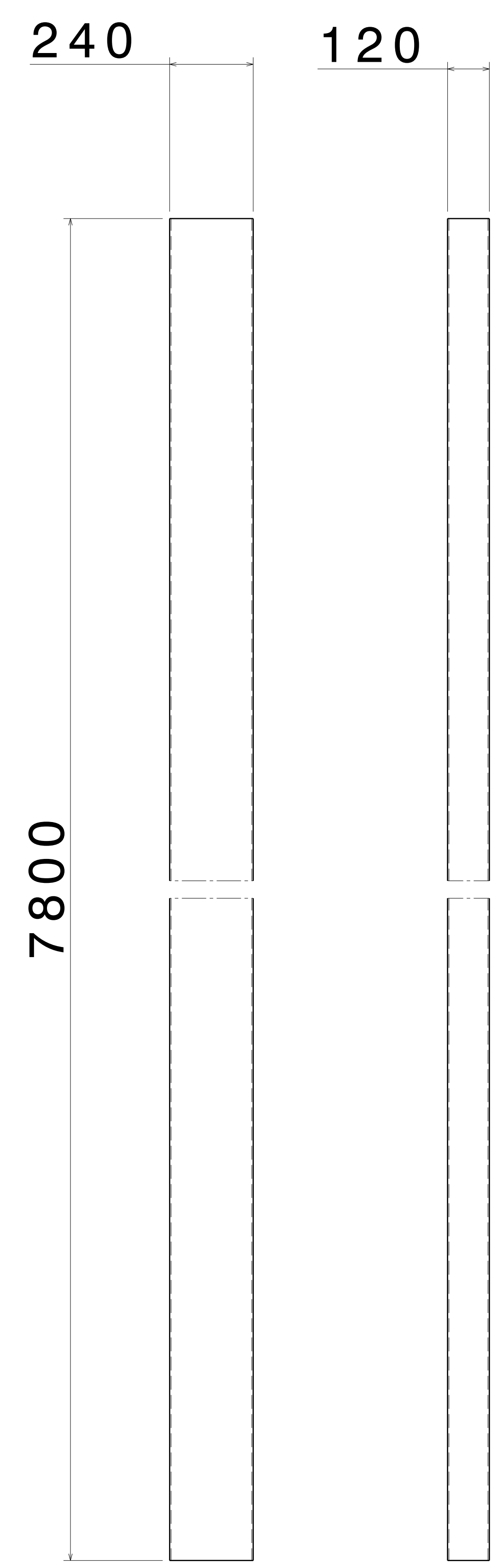

FRONT VIEW RIGHT VIEW
SCALE: 1:10 SCALE: 1:10
ITEM 9, RHS FRAME 7
THICKNESS - 4.0MM

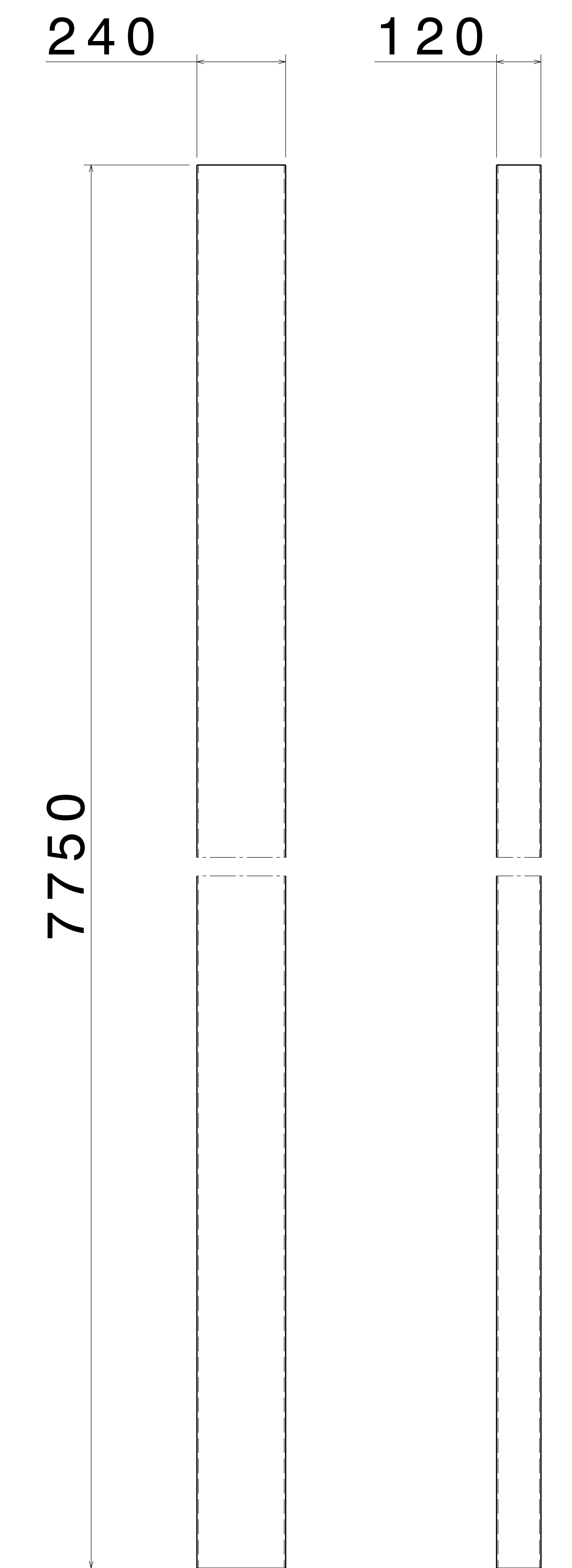

FRONT VIEW RIGHT VIEW
SCALE: 1:10 SCALE: 1:10
ITEM 10, RHS FRAME 8
THICKNESS - 4.0MM

UNLESS OTHERWISE SPECIFIED DIMENSION ARE IN MM
VIEWS: THIRD ANGLE PROJECTION

This drawing is our property. It can't be reproduced or communicated without our written agreement.		APL APOLLO TUBES LTD.	
DRAWN BY	DATE	DRAWING TITLE	
SB	5DEC2020	DEC 20 10	
CHECKED BY	DATE	SIZE	DRAWING NUMBER
P2P Analysis & Solutions	5DEC2020	A0	P2P DEC 20 10
DESIGNED BY	DATE	SCALE	WEIGHT (kg)
P2P Analysis & Solutions	5DEC2020	NONE	XXX
		SHEET 3 OF 3	