

REV/DATE	DESCRIPTION
00 / 3DEC2020	INITIAL REVISION

- NOTES:
- (⊥) ALL VERTICAL SUPPORTS ARE PERPENDICULAR.
  - FLATNESS OF .5MM IS APPLIED BY DEFAULT.
  - ⊲ WELD BEAD OF 2MM RADIUS IS FOLLOWED.
  - ▽ SURFACE FINISH MEDIUM TO SMOOTH IS USED.
  - ALL TUBES ARE AS PER APL APOLLO STANDARD. CHANGES MAY EFFECT THE LOAD CAPACITY.
  - ALL HORIZONTAL AND VERTICAL TUBES ARE PERPENDICULAR TO EACH OTHER WITH ±1 DEG.
  - FINE WELDING IS REQUIRED AS PER MENTIONED DETAILS AND FINISHING.
  - HIGHER CURRENT WELDING MAY AFFECT THE BRITTLENESS OF MATERIAL WHICH LATER MAY RAISE TO WEAKENING OF STRUCTURE.
  - FABRICATORS ARE ALLOWED TO USE FITTINGS/FRAMES/SUPPORTS AS NEEDED AND THE SAME MUST BE COMMUNICATED BACK TO ENGINEERING TEAM.
  - BOP COMPONENT WEIGHTS ARE FOR REFERENCE ONLY AND SUBJECTED TO CHANGE PER PURCHASED COMPONENTS.

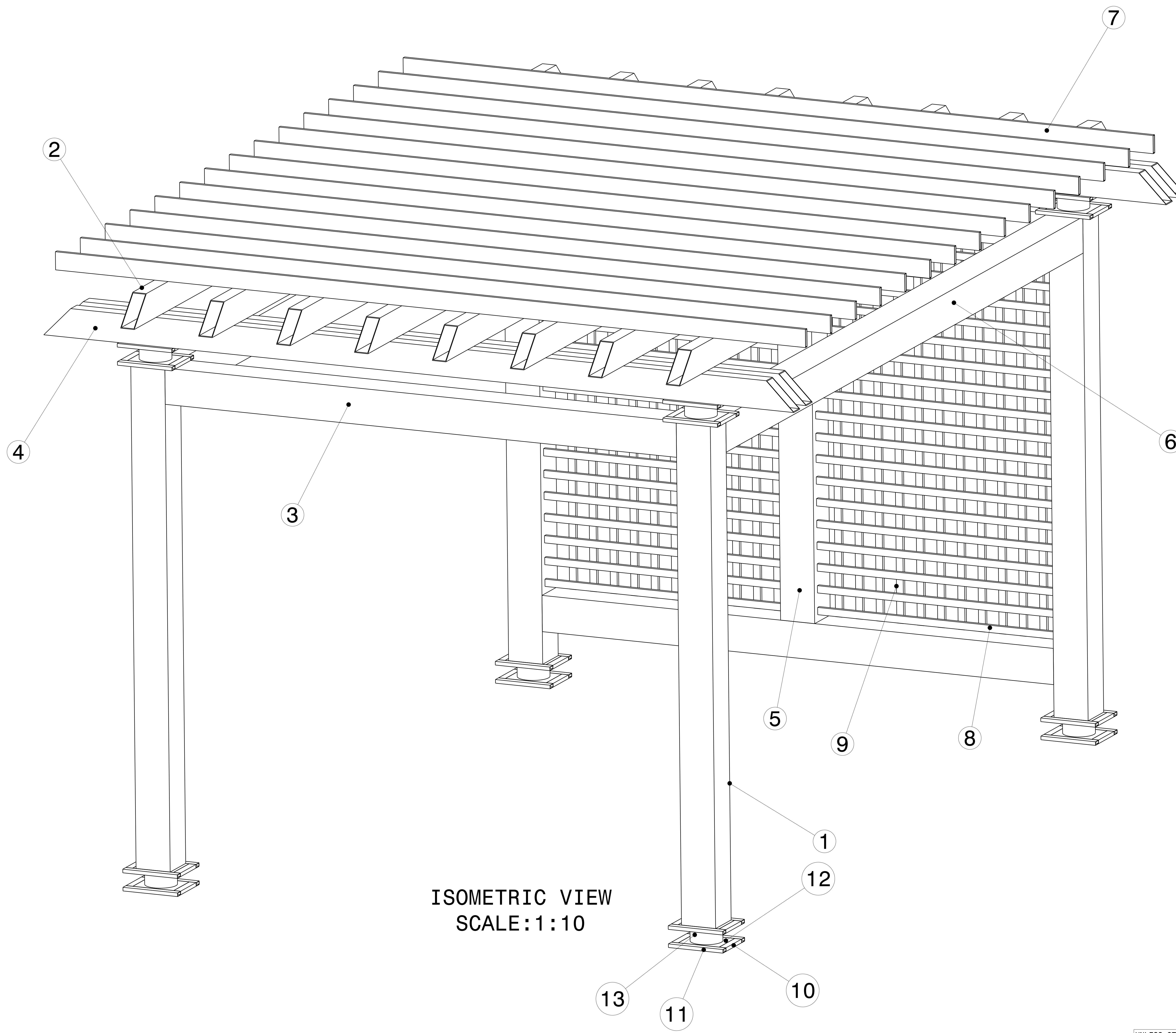

ISOMETRIC VIEW  
SCALE:1:10

ITEM NO.	PART NUMBER	DESCRIPTION	QTY.	Wt (Kg)/Each
13	CIRCULAR TUBE 1	DIA 219.1 X 6.3 THK X 100	8	3.31
12	RHS PLANK 2	150 X 25 X 2 X 250	32	1.34
11	RHS FRAME 6	50 X 25 X 2 X 400	32	1.14
10	RHS FRAME 5	50 X 25 X 2 X 250	32	0.71
9	RHS FRAME 4	50 X 25 X 2 X 2750	22	6.14
8	RHS FRAME 3	50 X 25 X 2 X 1750	36	3.91
7	RHS PLANK 1	125 X 25 X 2 X 5500	15	25.25
6	SHS FRAME 4	250 X 250 X 4 X 5750	2	22.63
5	SHS FRAME 3	250 X 250 X 4 X 2750	1	85.08
4	RHS FRAME 2	200 X 100 X 4 X 5500	4	97.31
3	SHS FRAME 2	250 X 250 X 4 X 3750	3	116.01
2	RHS FRAME 1	200 X 100 X 4 X 7000	8	124.85
1	SHS FRAME 1	250 X 250 X 8 X 3475	4	211.52

This drawing is our property. It can't be reproduced or communicated without our written agreement.

**APL APOLLO TUBES LTD.**

DRAWING TITLE: **DEC 20 2**

DRAWN BY: VM	DATE: 3DEC2020	CHECKED BY: P2P Analysis & Solutions	DATE: 3DEC2020	DESIGNED BY: P2P Analysis & Solutions	DATE: 3DEC2020
--------------	----------------	--------------------------------------	----------------	---------------------------------------	----------------

SIZE: A0	DRAWING NUMBER: P2P DEC 20 2	REV: 00
SCALE: As Indicated	WEIGHT(kg): 0kg	SHEET 1 OF 3

UNLESS OTHERWISE SPECIFIED DIMENSION ARE IN MM VIEWS: THIRD ANGLE PROJECTION

REV	DATE	DESCRIPTION
00	3DEC2020	INITIAL REVISION

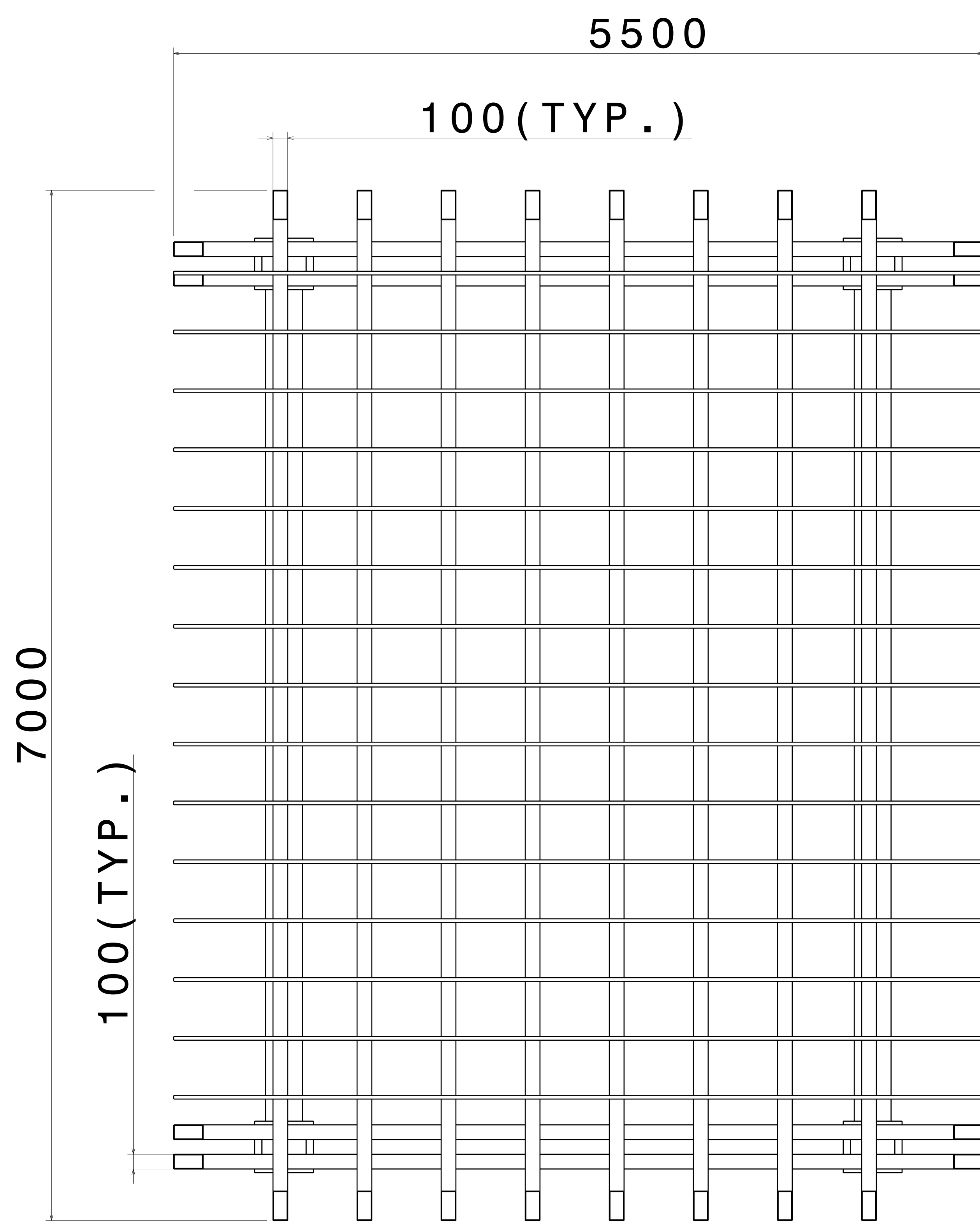

FRONT VIEW  
SCALE: 1:20

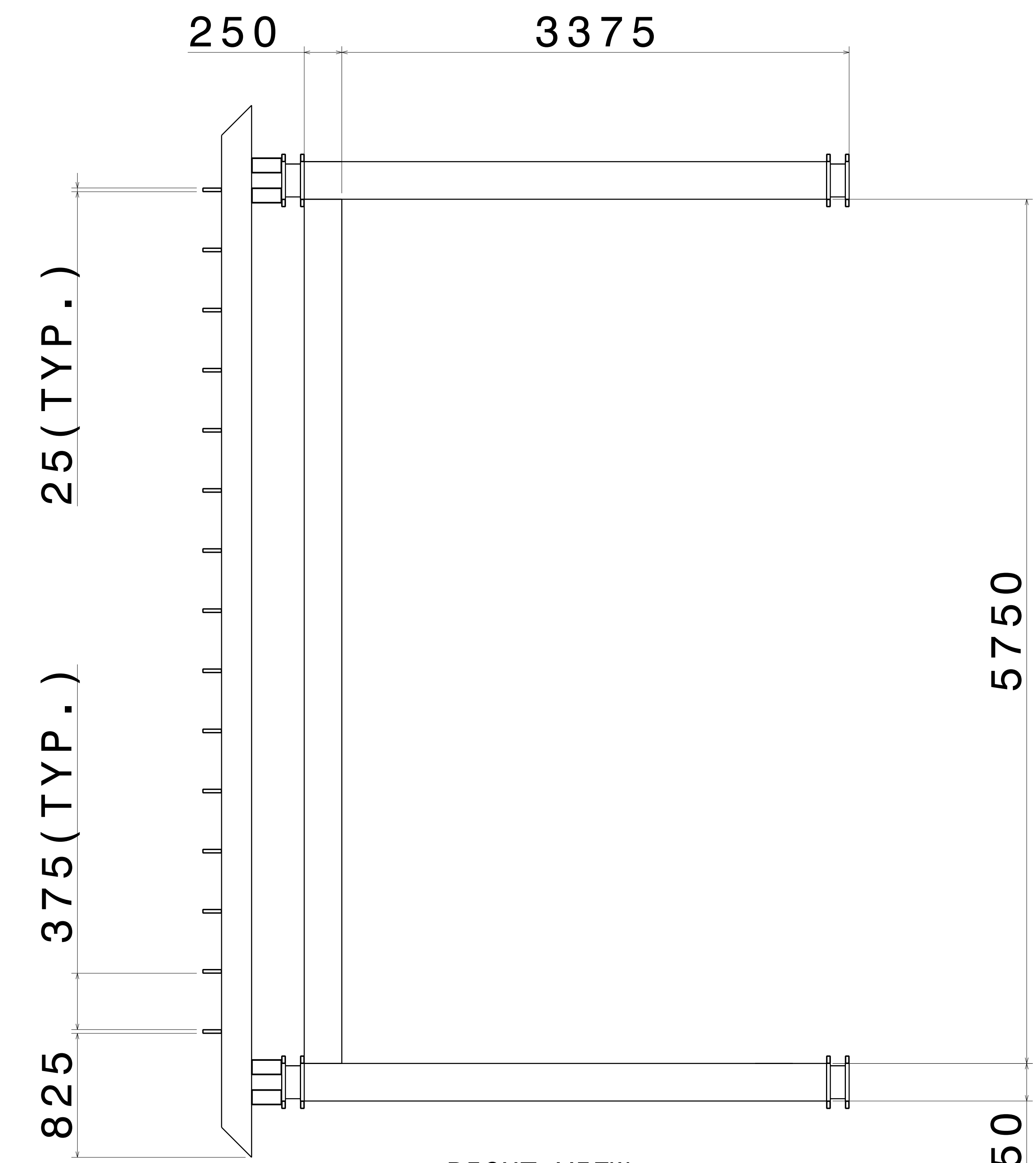

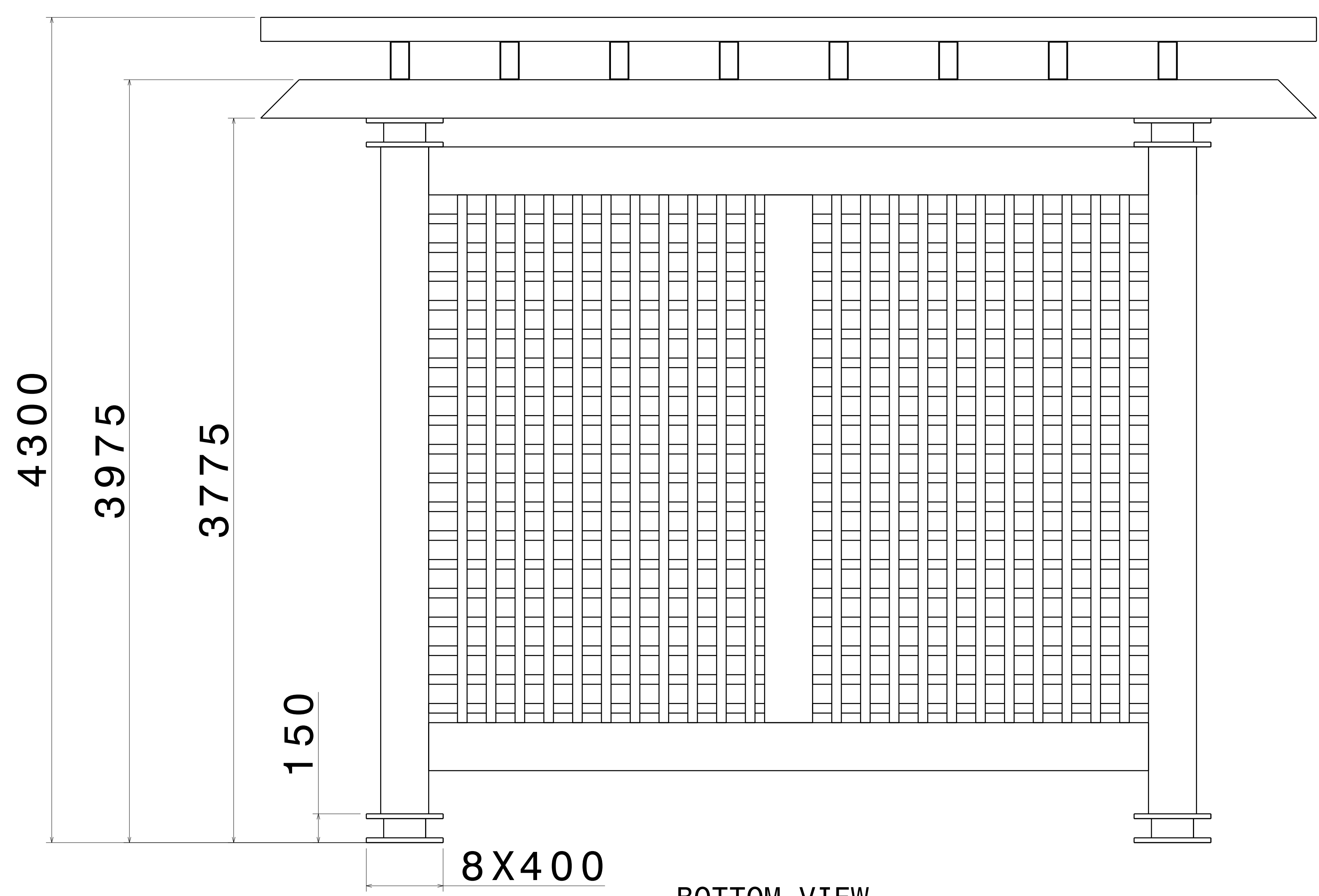

RIGHT VIEW  
SCALE: 1:20

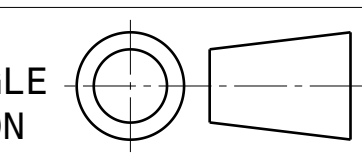

BOTTOM VIEW  
SCALE: 1:20

UNLESS OTHERWISE SPECIFIED DIMENSION ARE IN MM  
VIEWS: THIRD ANGLE PROJECTION



This drawing is our property. It can't be reproduced or communicated without our written agreement.		APL APOLLO TUBES LTD. 	
DRAWN BY SB		DATE 3DEC2020	
CHECKED BY P2P Analysis & Solutions		DATE 3DEC2020	
DESIGNED BY P2P Analysis & Solutions		DATE 3DEC2020	
SIZE A0	DRAWING NUMBER P2P_DEC 20 2		REV 00
SCALE NONE	WEIGHT (kg)	XXX	SHEET 2 OF 3



REV	DATE	DESCRIPTION
00	3DEC2020	INITIAL REVISION

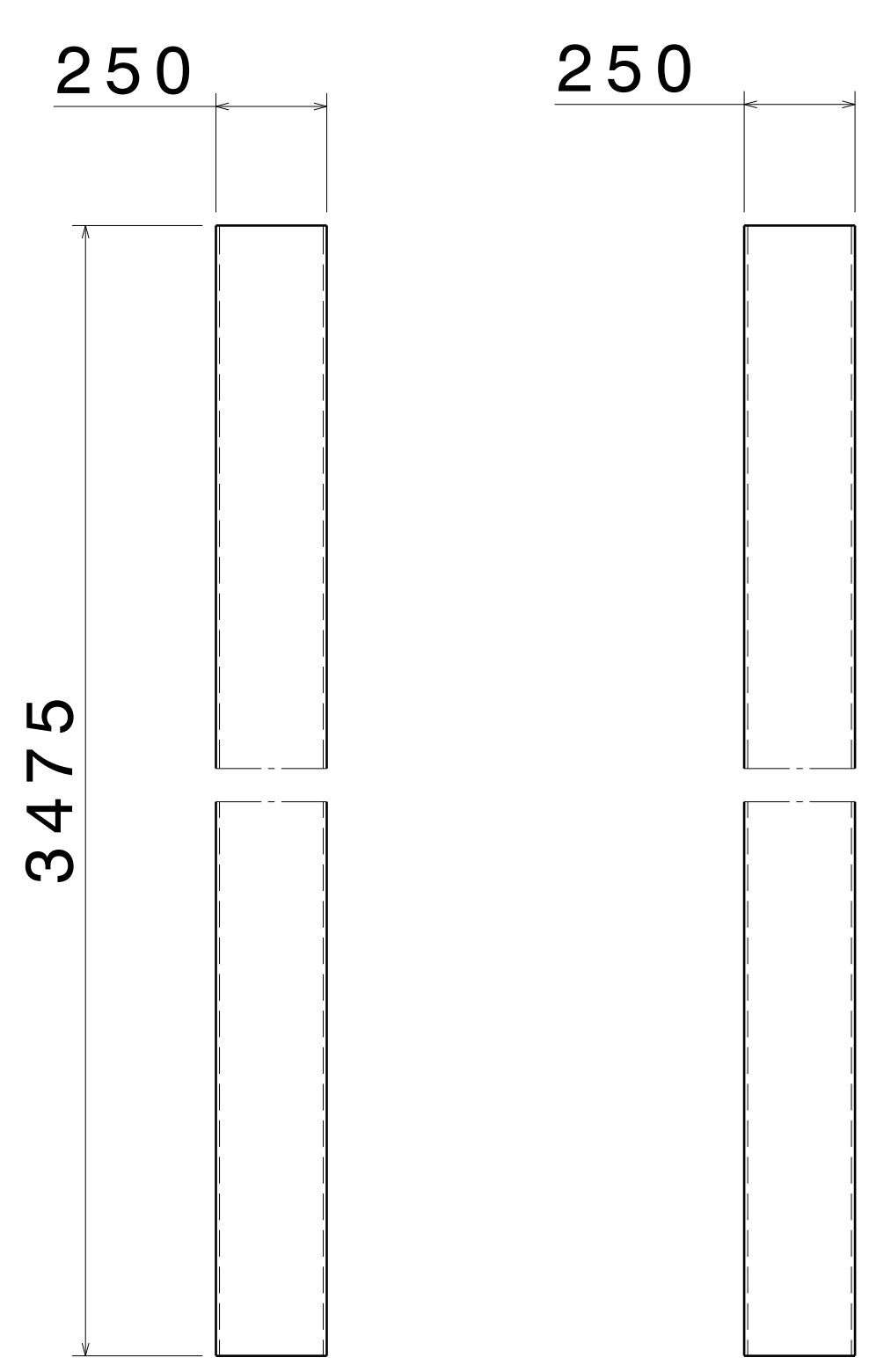

FRONT VIEW RIGHT VIEW  
SCALE: 1:15 SCALE: 1:15  
ITEM 1, SHS FRAME 1  
THICKNESS - 8.0MM

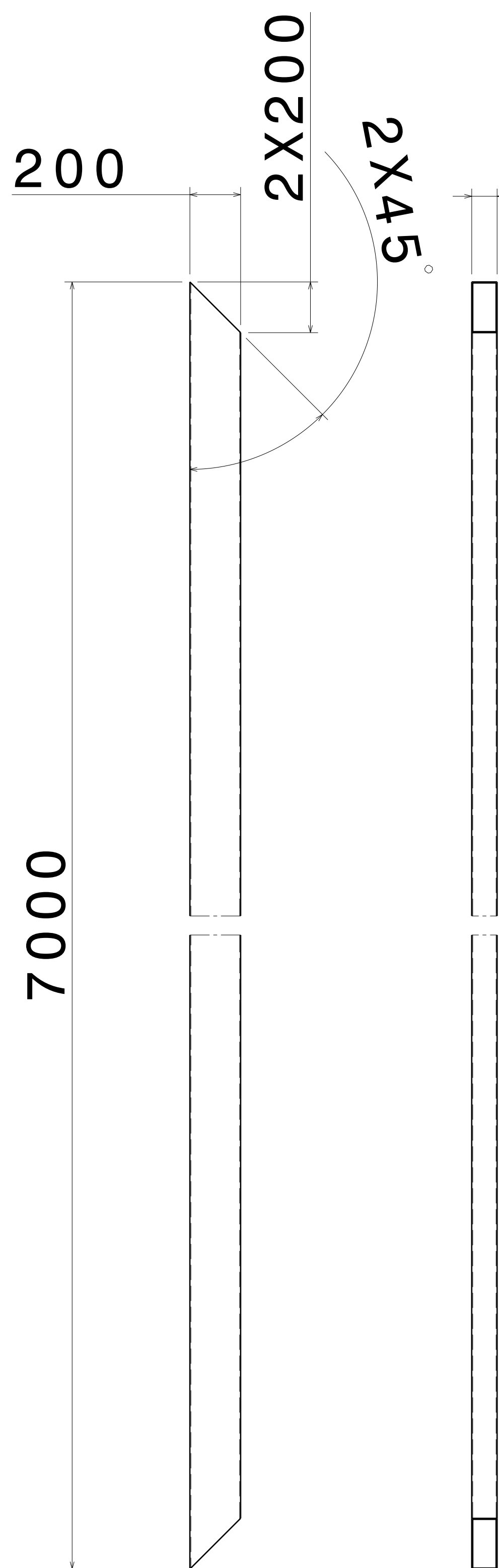

FRONT VIEW RIGHT VIEW  
SCALE: 1:15 SCALE: 1:15  
ITEM 2, SHS FRAME 2  
THICKNESS - 4.0 MM

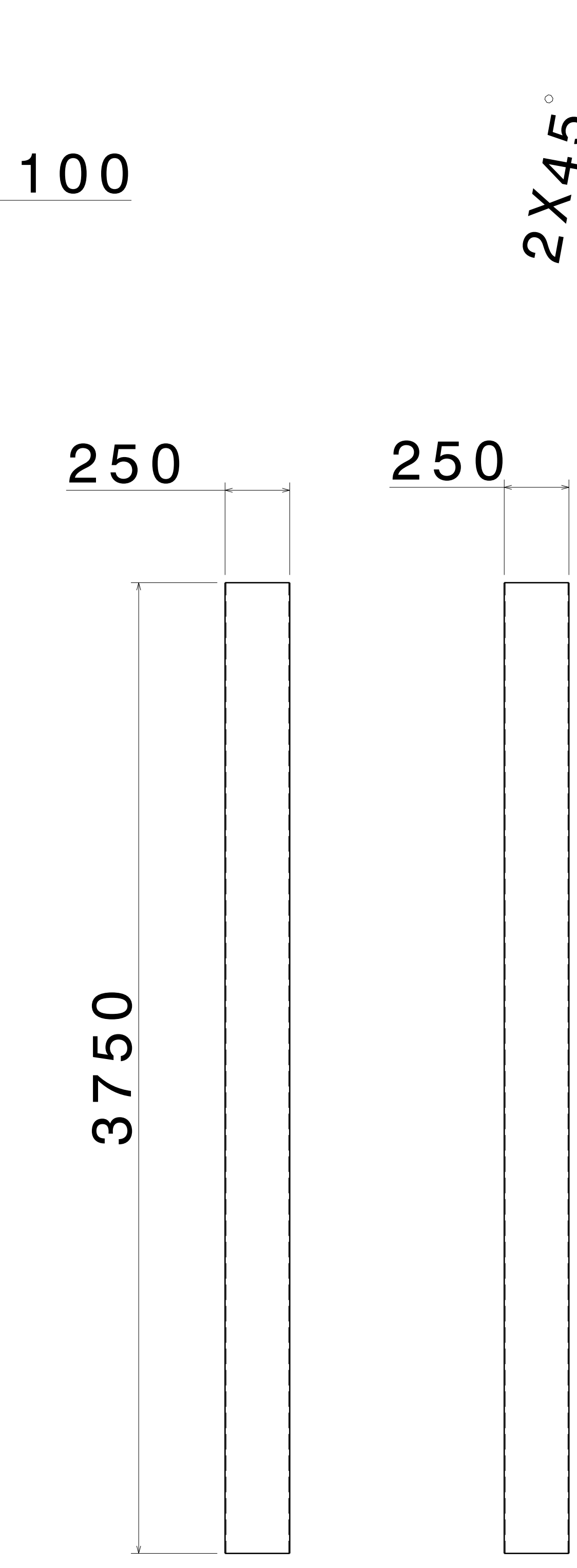

FRONT VIEW RIGHT VIEW  
SCALE: 1:15 SCALE: 1:15  
ITEM 3, SHS FRAME 2  
THICKNESS - 4.0 MM

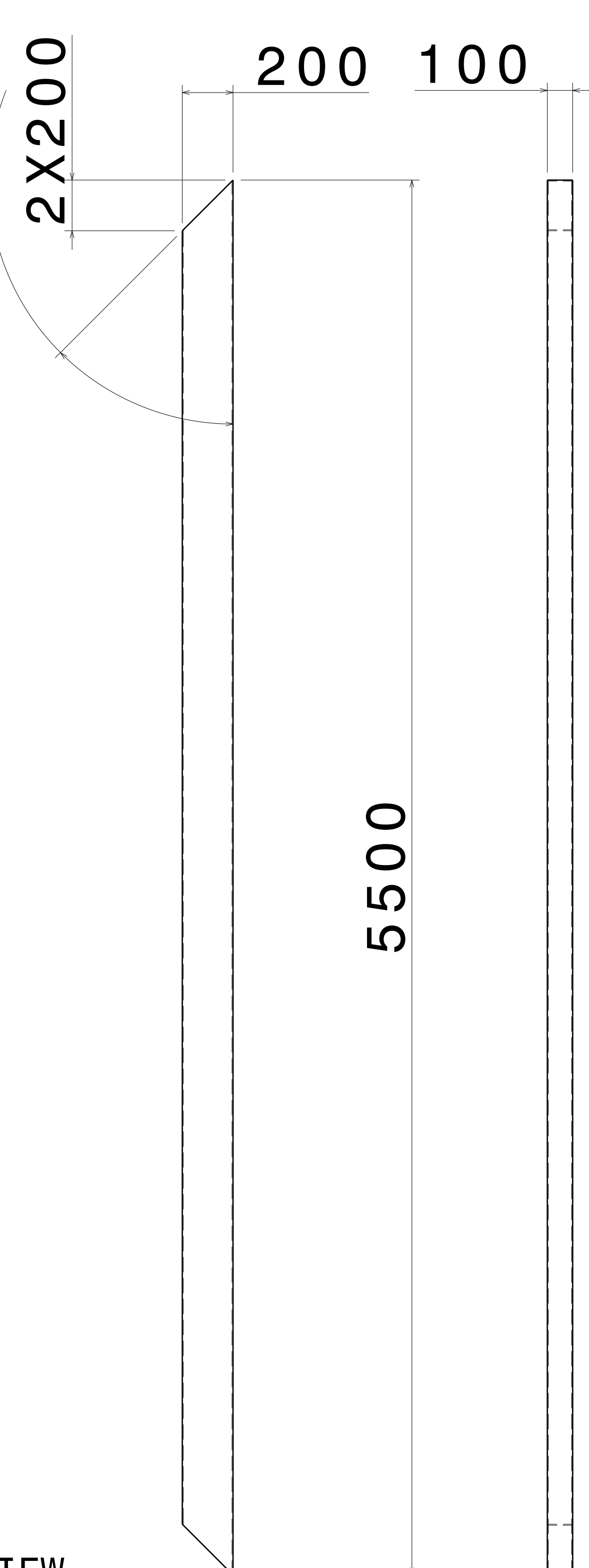

FRONT VIEW RIGHT VIEW  
SCALE: 1:15 SCALE: 1:15  
ITEM 4, RHS FRAME 2  
THICKNESS - 4.0 MM

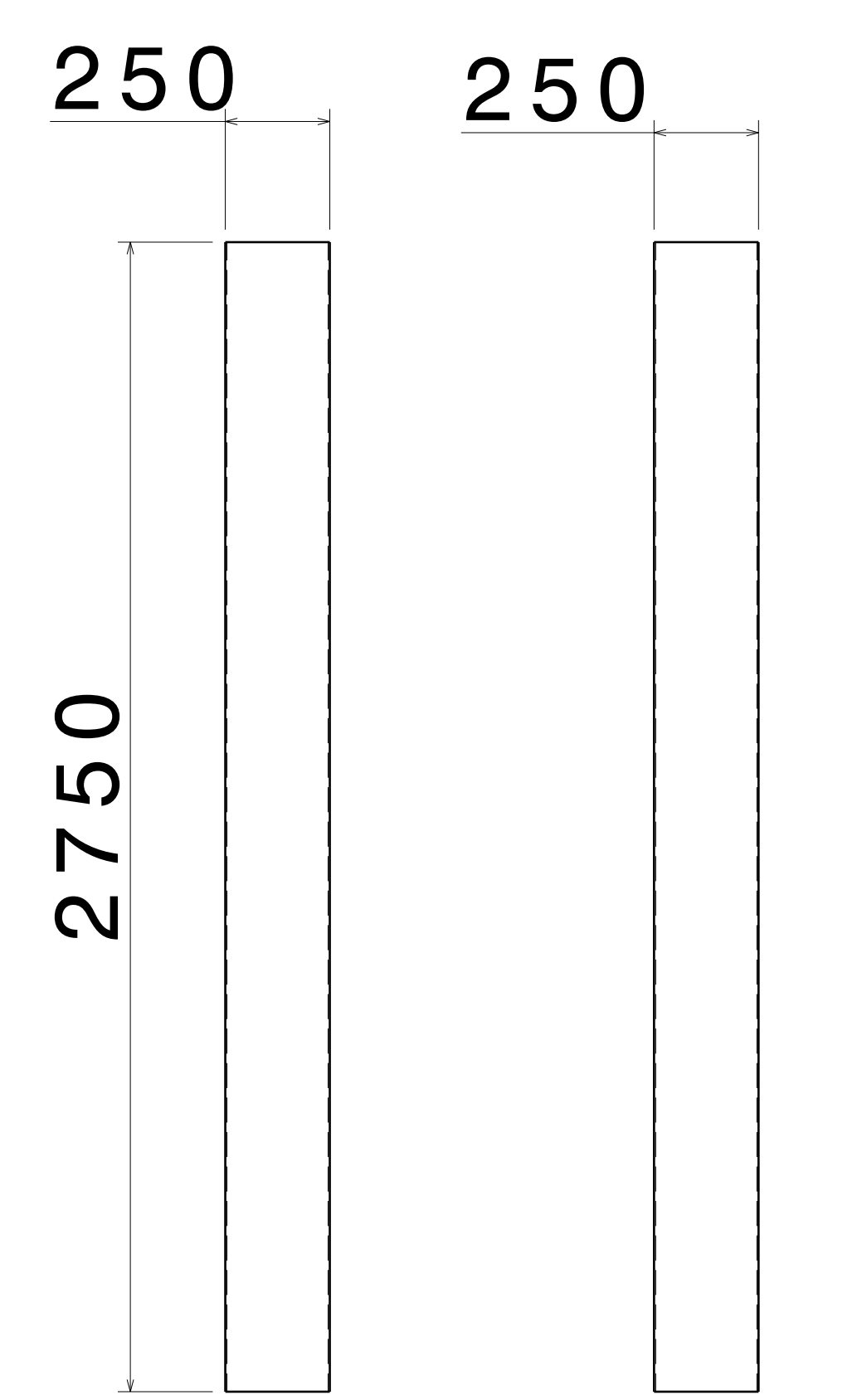

FRONT VIEW RIGHT VIEW  
SCALE: 1:15 SCALE: 1:15  
ITEM 5, SHS FRAME 3  
THICKNESS - 4.0 MM

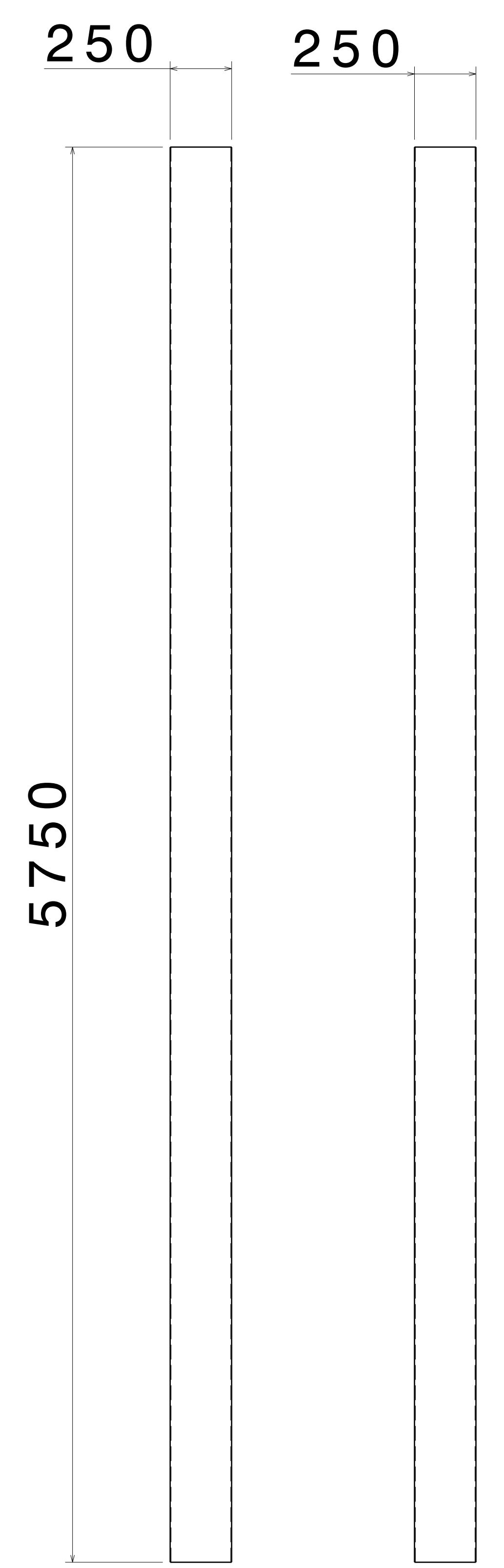

FRONT VIEW RIGHT VIEW  
SCALE: 1:15 SCALE: 1:15  
ITEM 6, SHS FRAME 4  
THICKNESS - 4.0 MM

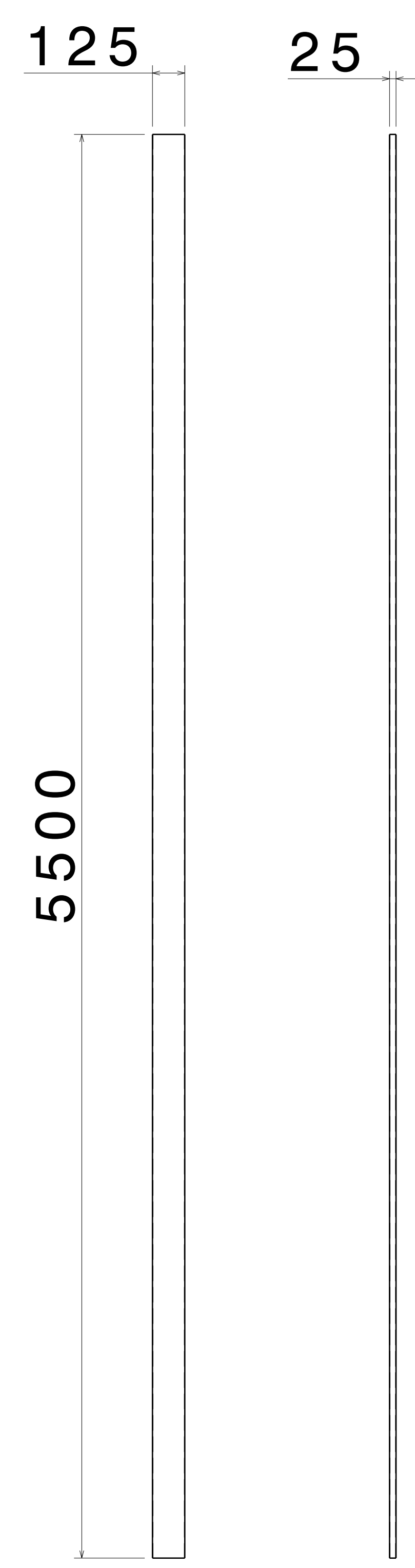

FRONT VIEW RIGHT VIEW  
SCALE: 1:15 SCALE: 1:15  
ITEM 7, RHS PLANK 1  
THICKNESS - 2.0 MM

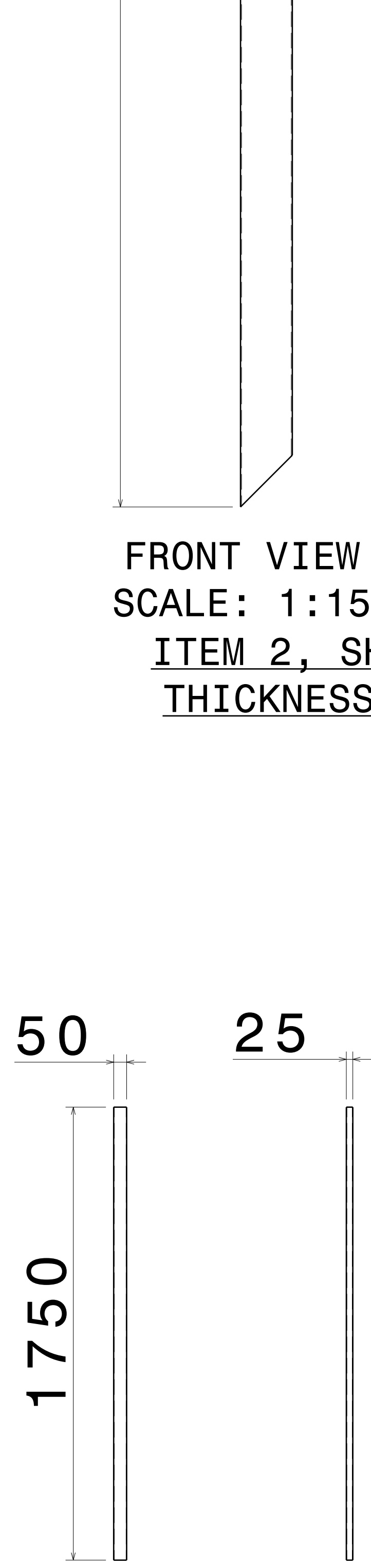

FRONT VIEW RIGHT VIEW  
SCALE: 1:15 SCALE: 1:15  
ITEM 8, RHS FRAME 4  
THICKNESS - 2.0 MM

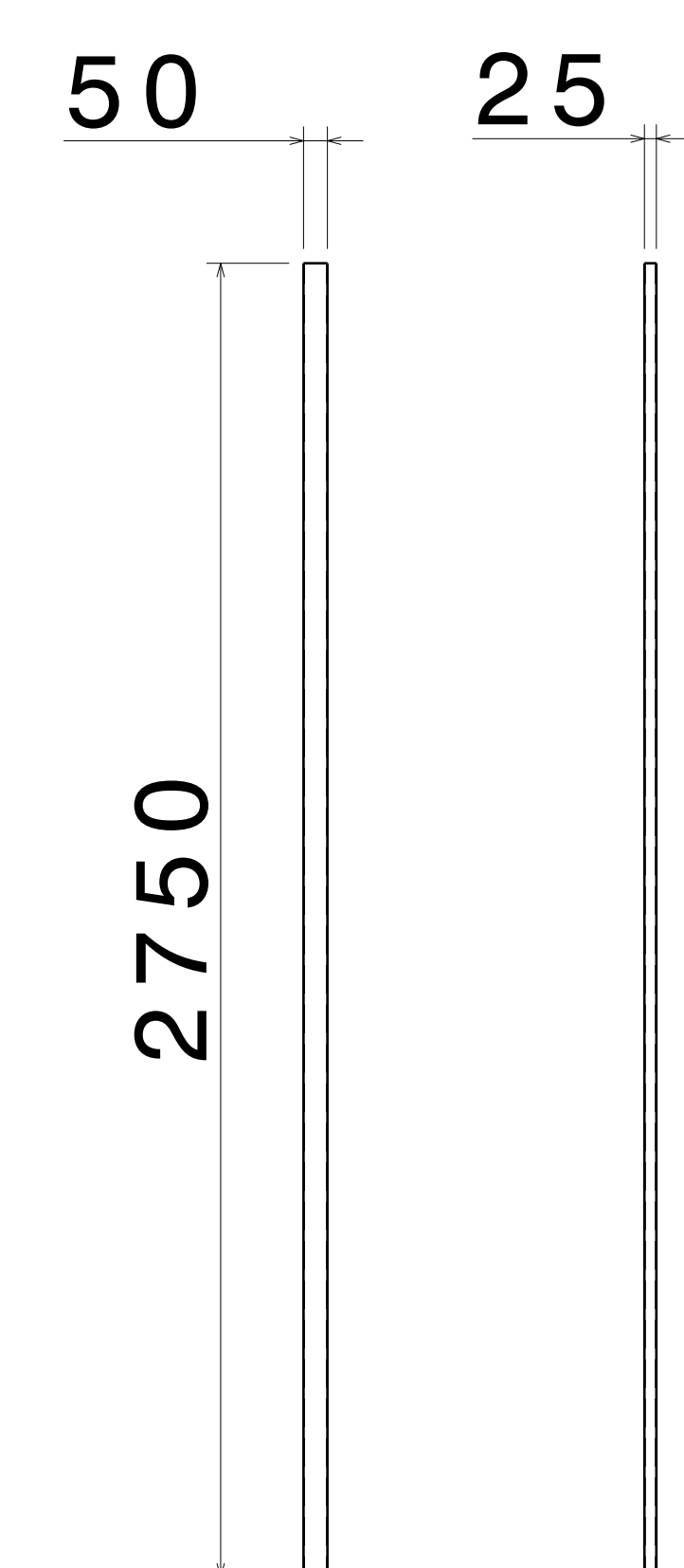

FRONT VIEW RIGHT VIEW  
SCALE: 1:15 SCALE: 1:15  
ITEM 9, RHS FRAME 5  
THICKNESS - 2.0 MM

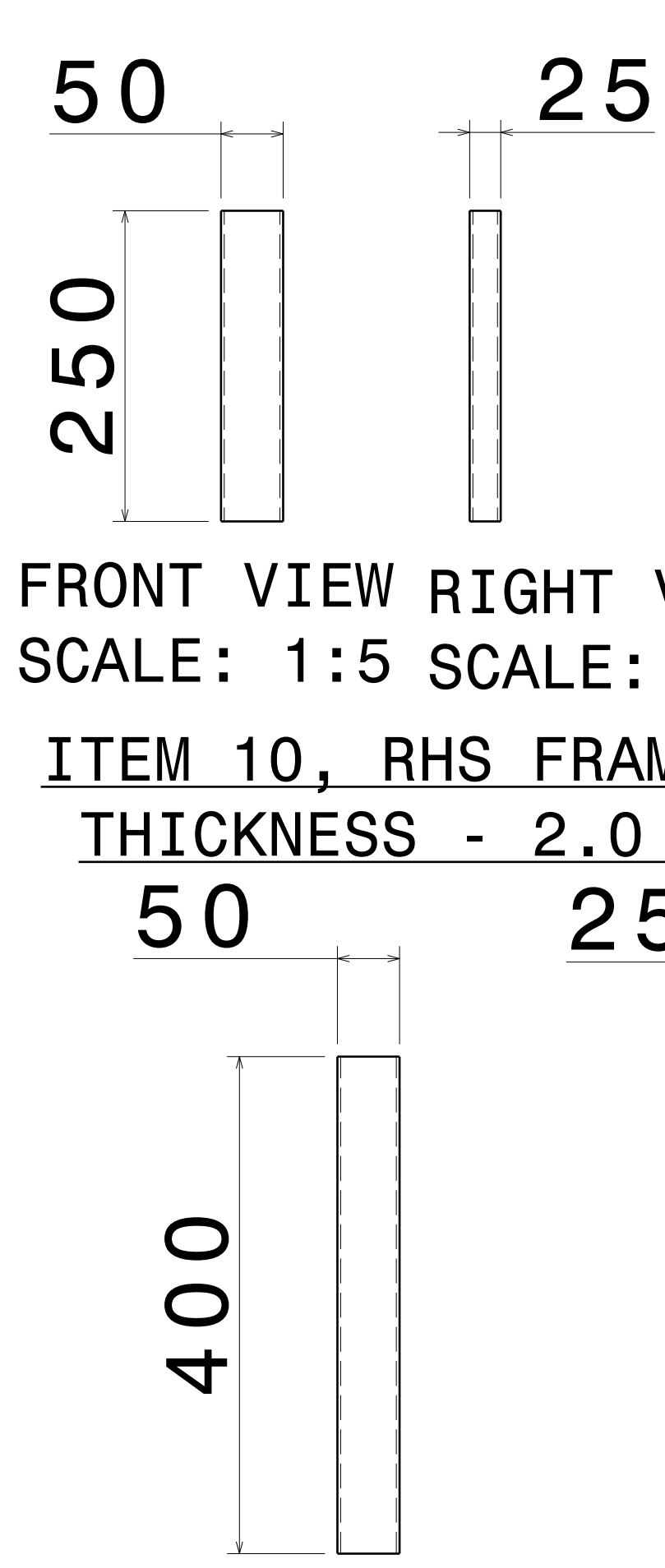

FRONT VIEW RIGHT VIEW  
SCALE: 1:5 SCALE: 1:5  
ITEM 10, RHS FRAME 5  
THICKNESS - 2.0 MM

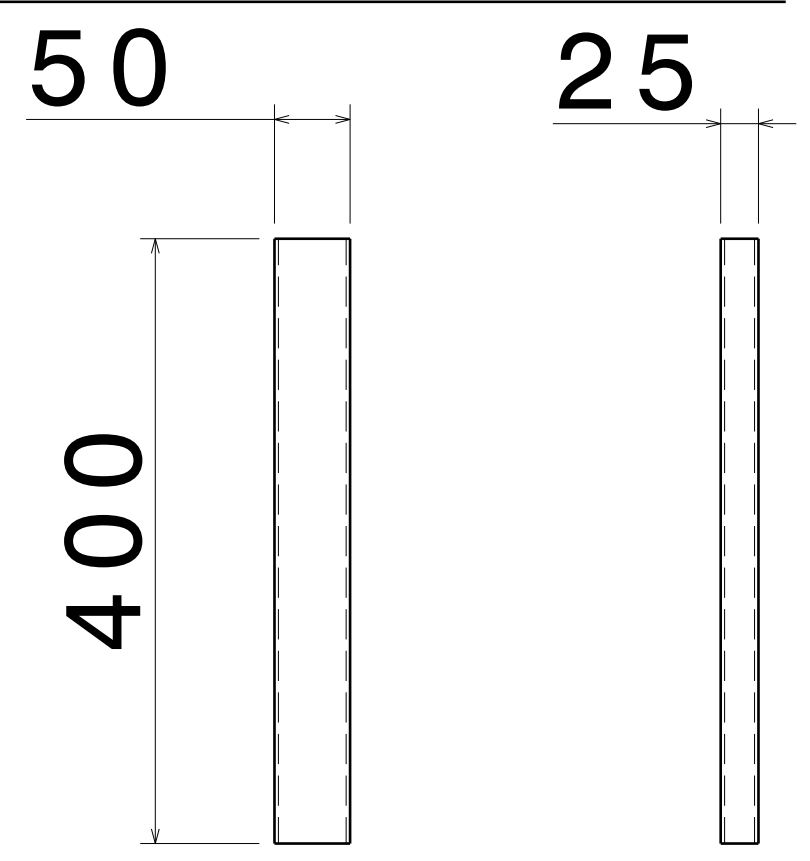

FRONT VIEW RIGHT VIEW  
SCALE: 1:5 SCALE: 1:5  
ITEM 11, RHS FRAME 6  
THICKNESS - 2.0 MM

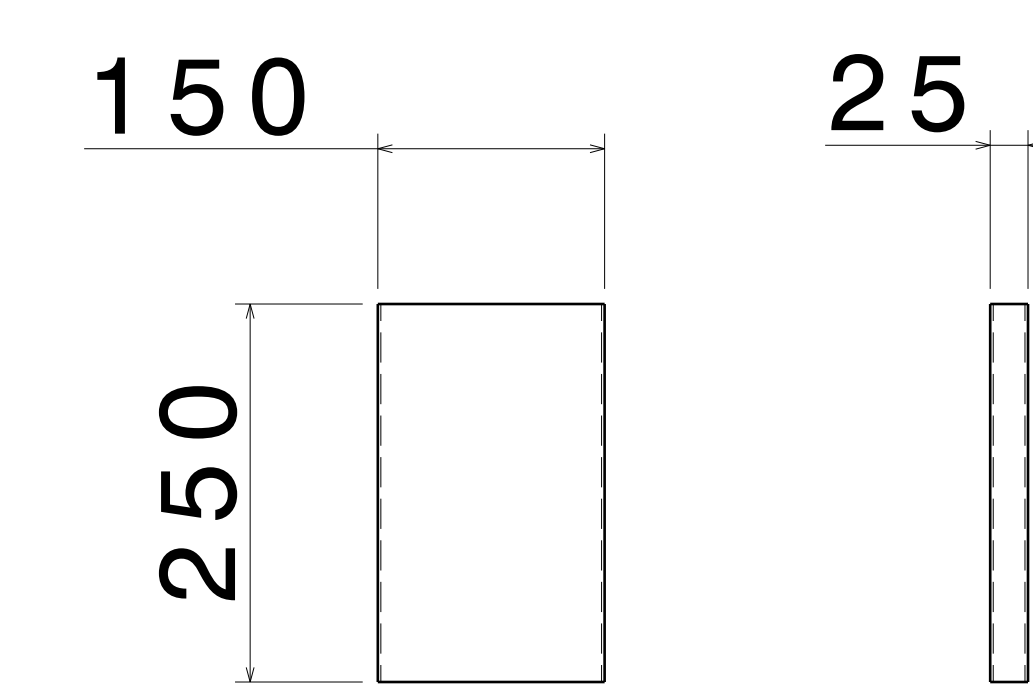

FRONT VIEW RIGHT VIEW  
SCALE: 1:5 SCALE: 1:5  
ITEM 12, RHS PLANK 2  
THICKNESS - 2.0 MM

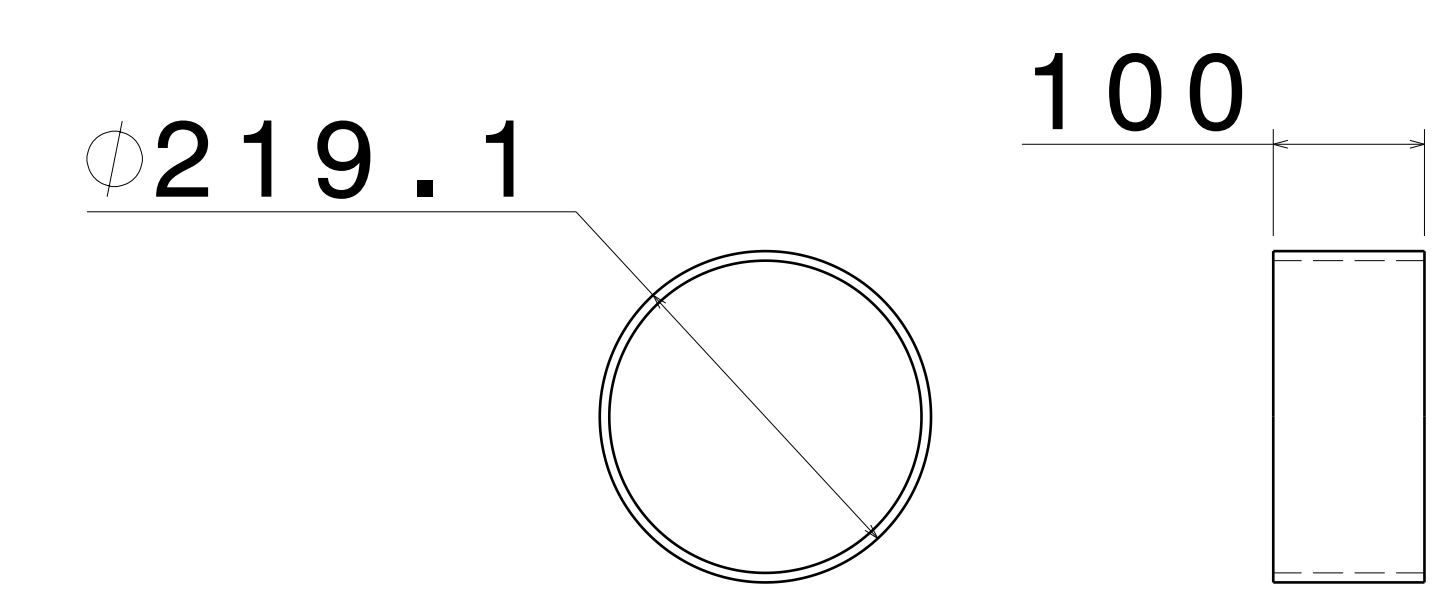

FRONT VIEW RIGHT VIEW  
SCALE: 1:5 SCALE: 1:5  
ITEM 13, CIRCULAR TUBE 1  
THICKNESS - 6.3 MM

UNLESS OTHERWISE SPECIFIED DIMENSION ARE IN MM  
VIEWS: THIRD ANGLE PROJECTION

This drawing is our property. It can't be reproduced or communicated without our written agreement.		APL APOLLO TUBES LTD.	
DRAWN BY SB		DRAWING TITLE DEC 20_2	
CHECKED BY P2P Analysis & Solutions	DATE 3DEC2020	SIZE A0	DRAWING NUMBER P2P_DEC 20_2
DESIGNED BY P2P Analysis & Solutions	DATE 3DEC2020	SCALE NONE	WEIGHT (kg) XXX
		SHEET 3 OF 3	