

REV	DATE	DESCRIPTION
00	4DEC2020	INITIAL REVISION

- NOTES:
- (⊥) ALL VERTICAL SUPPORTS ARE PERPENDICULAR.
 - FLATNESS OF .5MM IS APPLIED BY DEFAULT.
 - ⊲ WELD BEAD OF 2MM RADIUS IS FOLLOWED.
 - ▽ SURFACE FINISH MEDIUM TO SMOOTH IS USED.
 - ALL TUBES ARE AS PER APL APOLLO STANDARD. CHANGES MAY EFFECT THE LOAD CAPACITY.
 - ALL HORIZONTAL AND VERTICAL TUBES ARE PERPENDICULAR TO EACH OTHER WITH ±1 DEG.
 - FINE WELDING IS REQUIRED AS PER MENTIONED DETAILS AND FINISHING.
 - HIGHER CURRENT WELDING MAY AFFECT THE BRITTLNESS OF MATERIAL WHICH LATER MAY RAISE TO WEAKENING OF STRUCTURE.
 - FABRICATORS ARE ALLOWED TO USE FITTINGS/FRAMES/SUPPORTS AS NEEDED AND THE SAME MUST BE COMMUNICATED BACK TO ENGINEERING TEAM.
 - BOP COMPONENT WEIGHTS ARE FOR REFERENCE ONLY AND SUBJECTED TO CHANGE PER PURCHASED COMPONENTS.

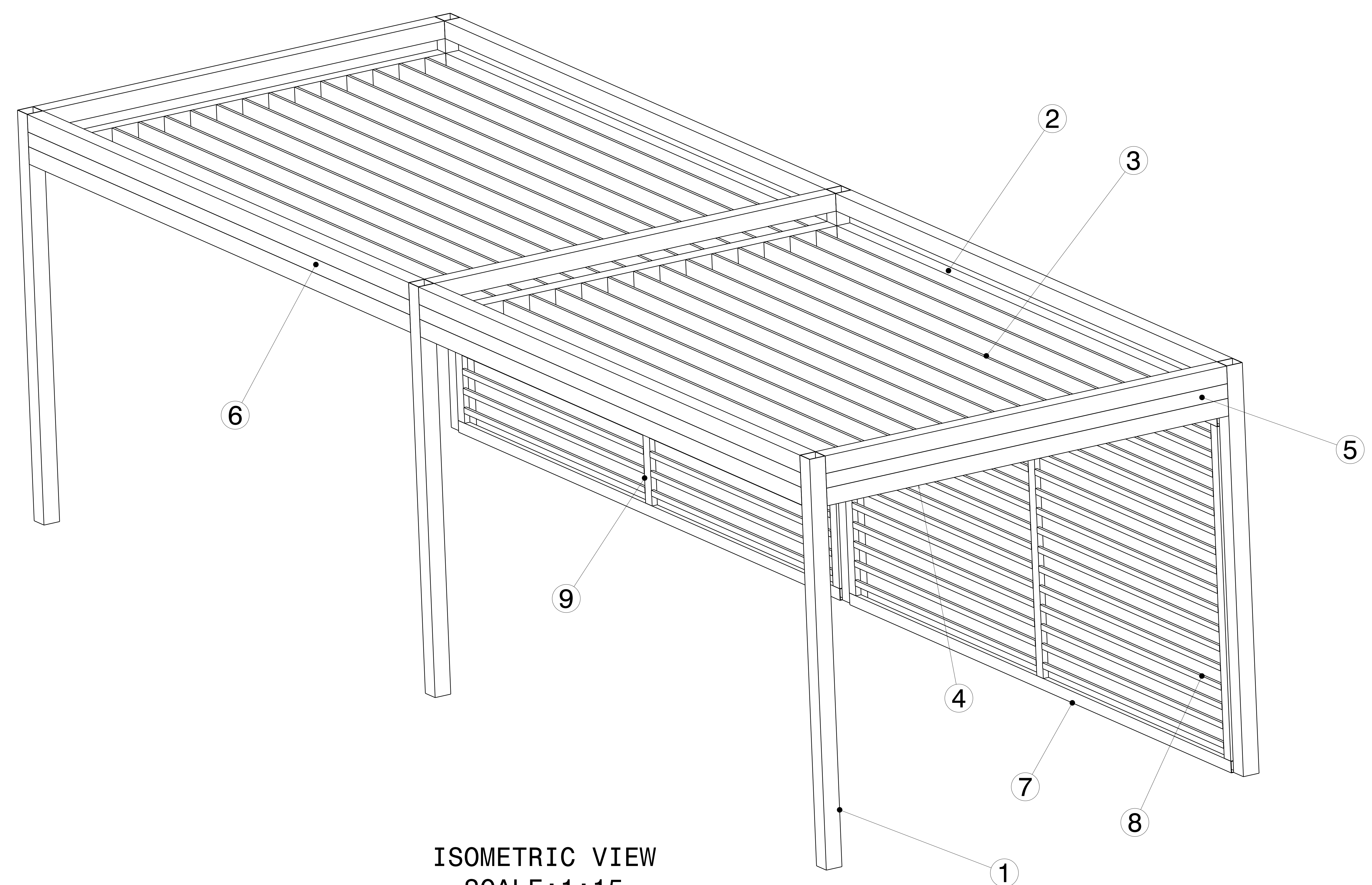

ISOMETRIC VIEW
SCALE:1:15

ITEM NO.	PART NUMBER	DESCRIPTION	QTY.	Wt (kg)/Each
9	RHS FRAME 3	100 X 50 X 3.6 X 2850	6	23.03
8	RHS FRAME 2	50 X 25 X 2 X 2775	68	6.19
7	RHS FRAME 1	100 X 50 X 3.6 X 5850	4	47.28
6	RHS PLANK 3	125 X 25 X 1.6 X 5850	4	21.6
5	RHS PLANK 2	125 X 25 X 1.6 X 3850	2	14.22
4	SHS FRAME 3	150 X 150 X 4 X 3850	6	70.69
3	RHS PLANK 1	150 X 25 X 1.6 X 5850	30	25.28
2	SHS FRAME 2	150 X 150 X 4 X 5850	8	107.41
1	SHS FRAME 1	150 X 150 X 4 X 3500	6	64.26

This drawing is our property. It can't be reproduced or communicated without our written agreement.

APL APOLLO TUBES LTD.

DRAWING TITLE: **DEC 20 9**

DRAWN BY: VM	DATE: 4DEC2020	CHECKED BY: P2P Analysis & Solutions	DATE: 4DEC2020	DESIGNED BY: P2P Analysis & Solutions	DATE: 4DEC2020
--------------	----------------	--------------------------------------	----------------	---------------------------------------	----------------

SIZE: A0	DRAWING NUMBER: P2P DEC 20 9	REV: 00
SCALE: As Indicated	WEIGHT(kg): 0kg	SHEET 1 OF 3

UNLESS OTHERWISE SPECIFIED DIMENSION ARE IN MM
VIEWS: THIRD ANGLE PROJECTION

REV	DATE	DESCRIPTION
00	4DEC2020	INITIAL REVISION

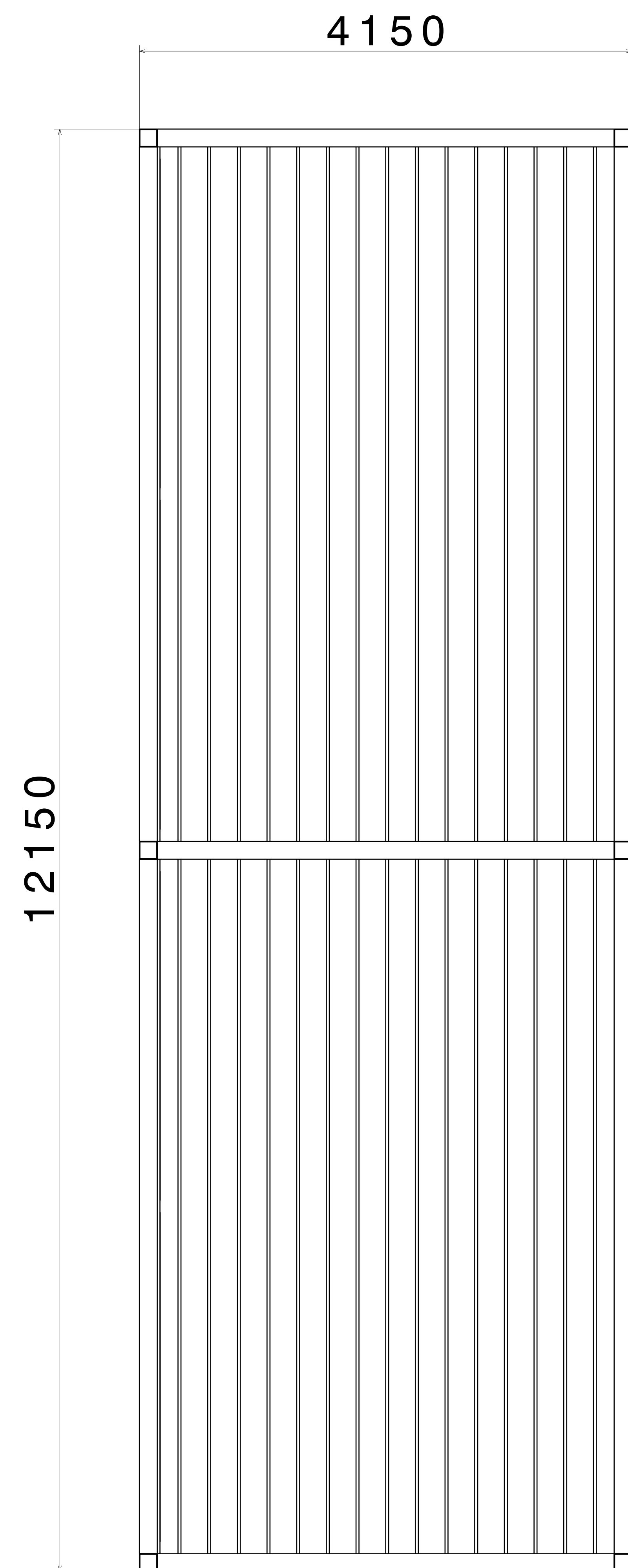

FRONT VIEW
SCALE: 1:25

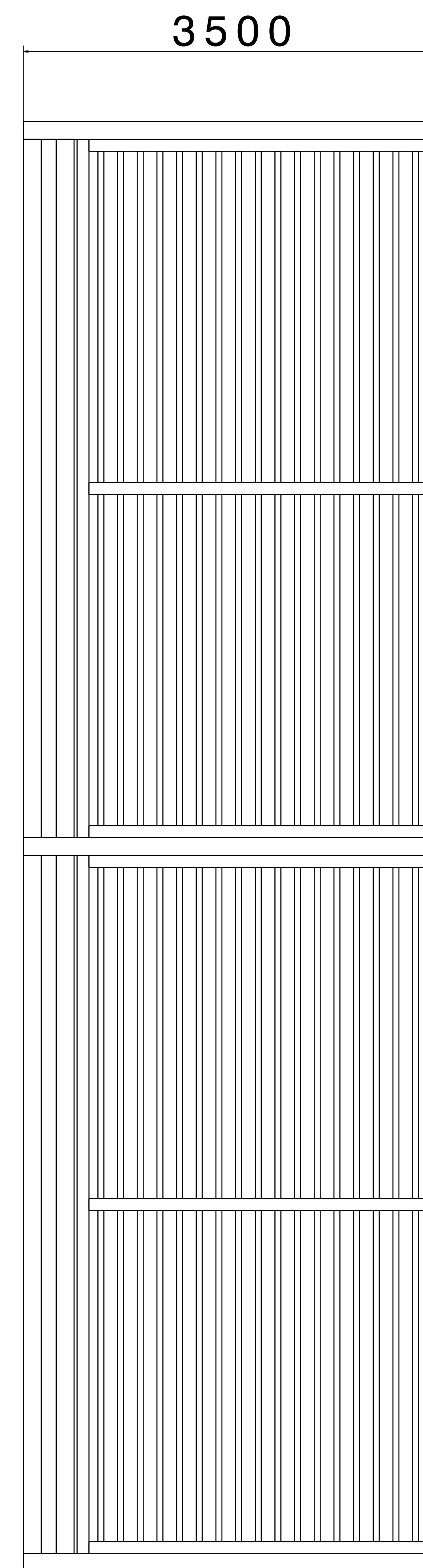

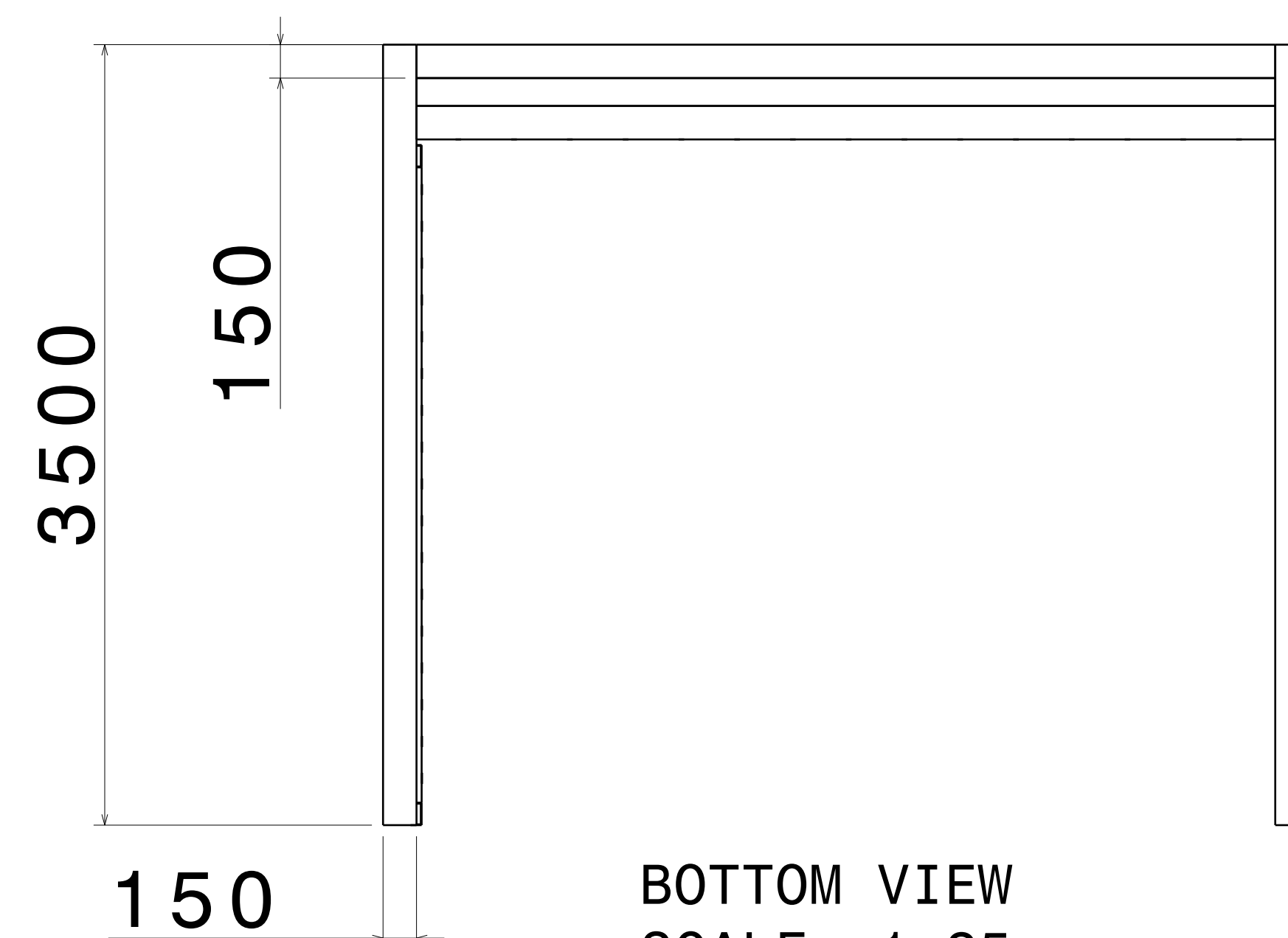

RIGHT VIEW
SCALE: 1:25

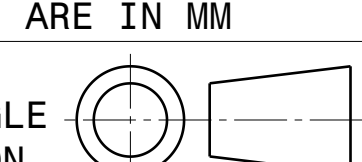

BOTTOM VIEW
SCALE: 1:25

UNLESS OTHERWISE SPECIFIED
DIMENSION ARE IN MM
VIEWS:
THIRD ANGLE PROJECTION



This drawing is our property. It can't be reproduced or communicated without our written agreement.		APL APOLLO TUBES LTD. 	
DRAWN BY SB		DATE 4DEC2020	
CHECKED BY P2P Analysis & Solutions		DATE 4DEC2020	
DESIGNED BY P2P Analysis & Solutions		DATE 4DEC2020	
SIZE A0	DRAWING NUMBER P2P_DEC 20 9		REV 00
SCALE NONE	WEIGHT (kg)	XXX	SHEET 2 OF 3

DRAWING TITLE
DEC 20 9

REV	DATE	DESCRIPTION
00	4DEC2020	INITIAL REVISION

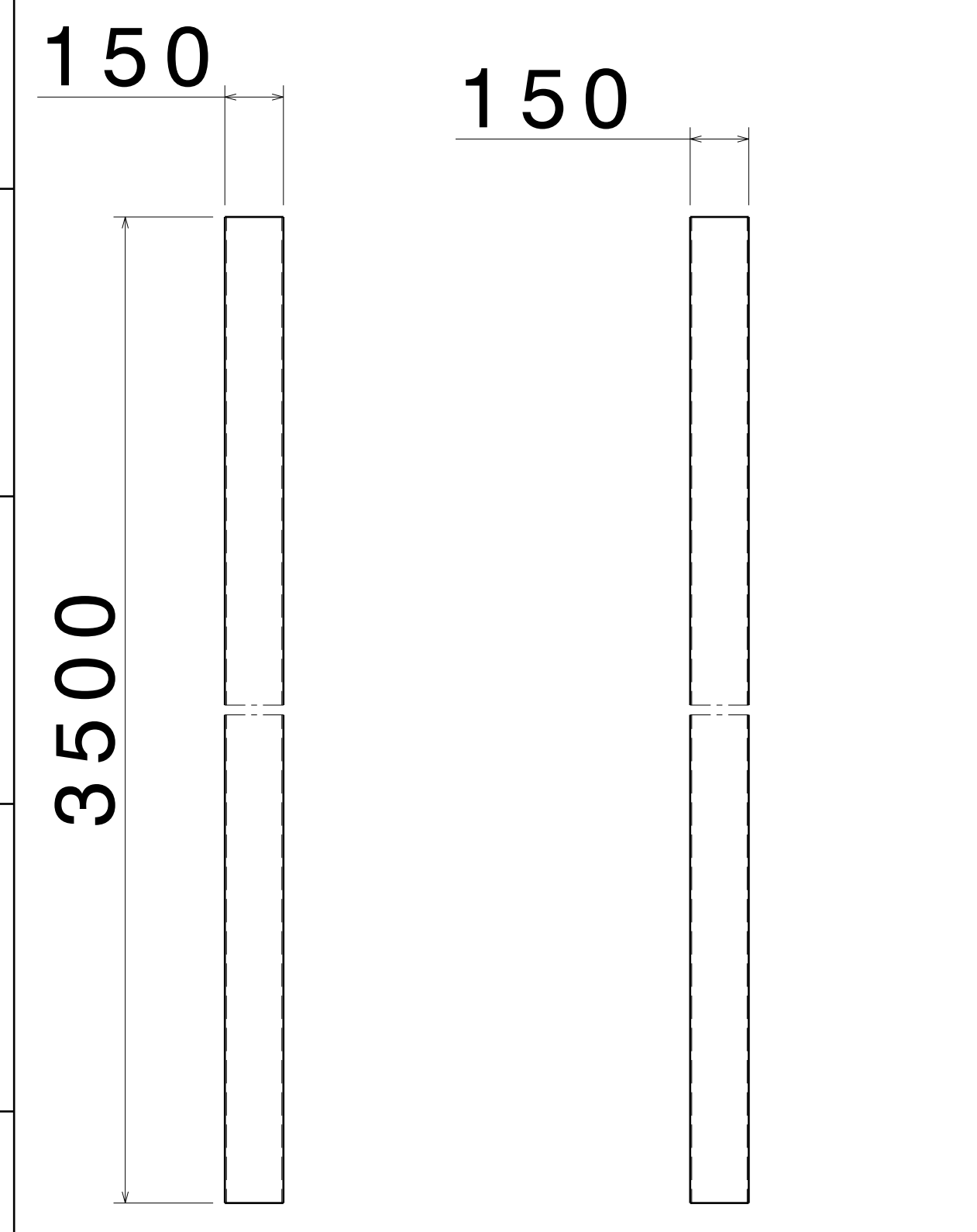

FRONT VIEW RIGHT VIEW
SCALE: 1:15 SCALE: 1:15
ITEM 1, SHS FRAME 1
THICKNESS - 4.0MM

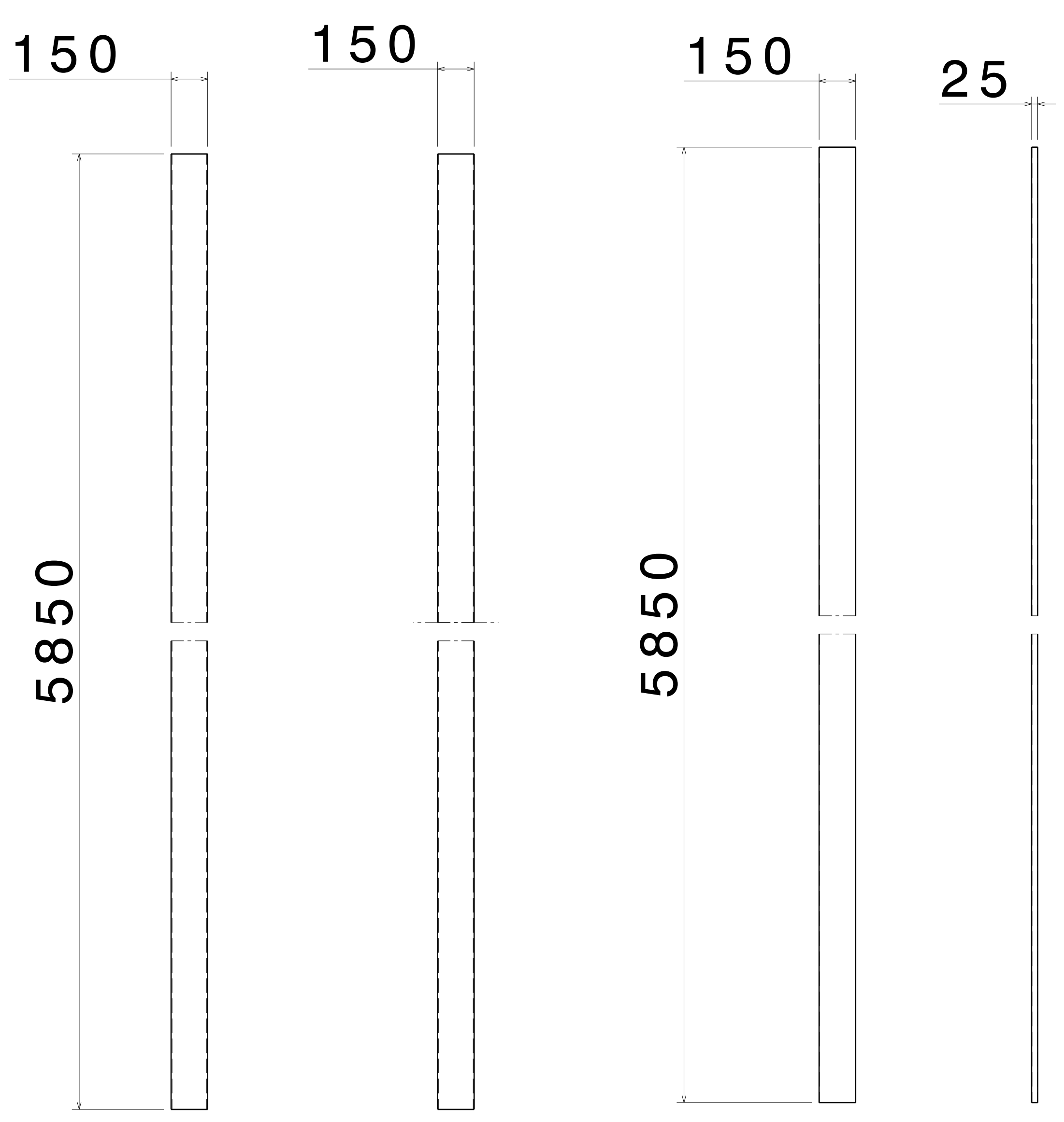

FRONT VIEW RIGHT VIEW
SCALE: 1:15 SCALE: 1:15
ITEM 2, SHS FRAME 2
THICKNESS - 4.0 MM

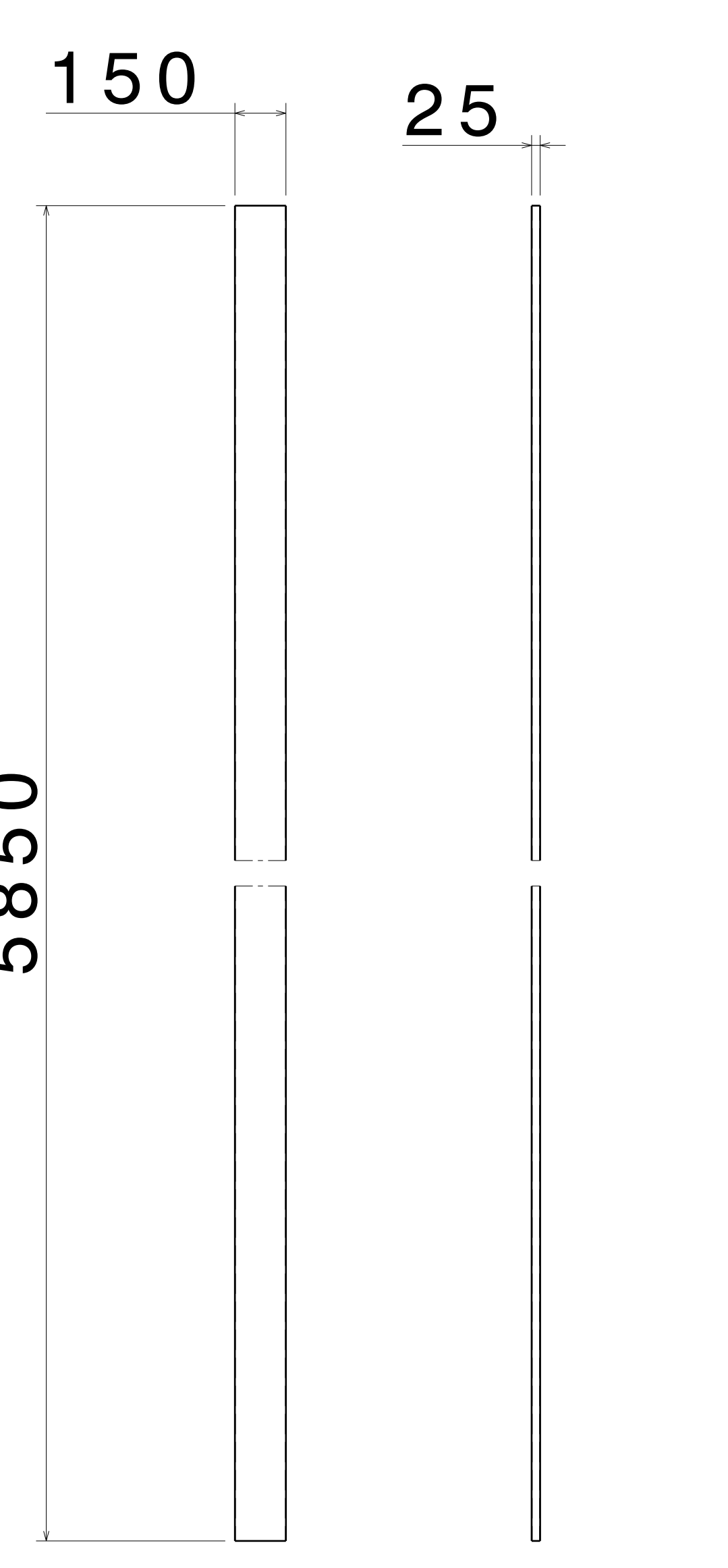

FRONT VIEW RIGHT VIEW
SCALE: 1:15 SCALE: 1:15
ITEM 3, RHS PLANK 1
THICKNESS -1.6 MM

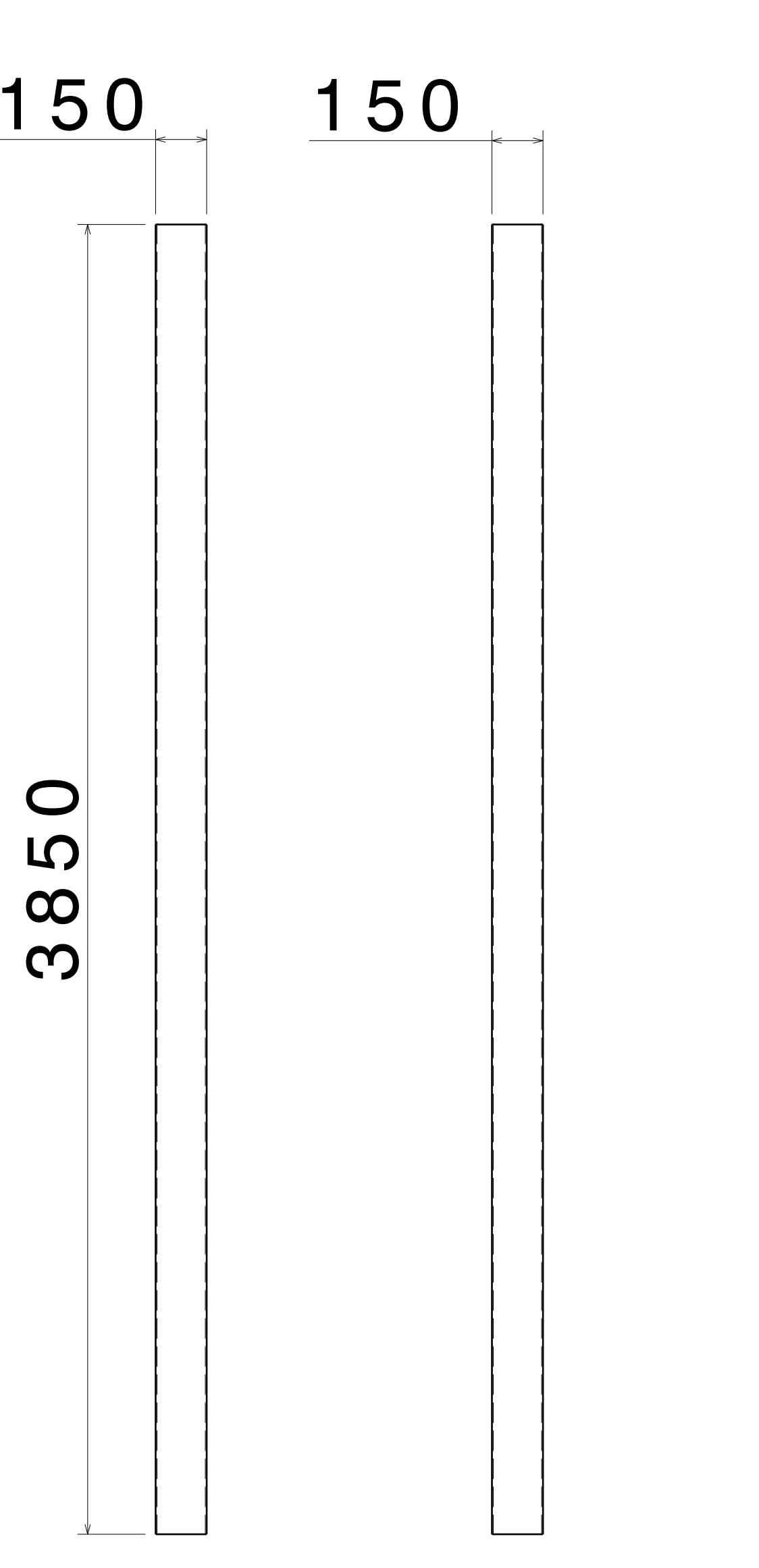

FRONT VIEW RIGHT VIEW
SCALE: 1:15 SCALE: 1:15
ITEM 4, SHS FRAME 3
THICKNESS - 4.0 MM

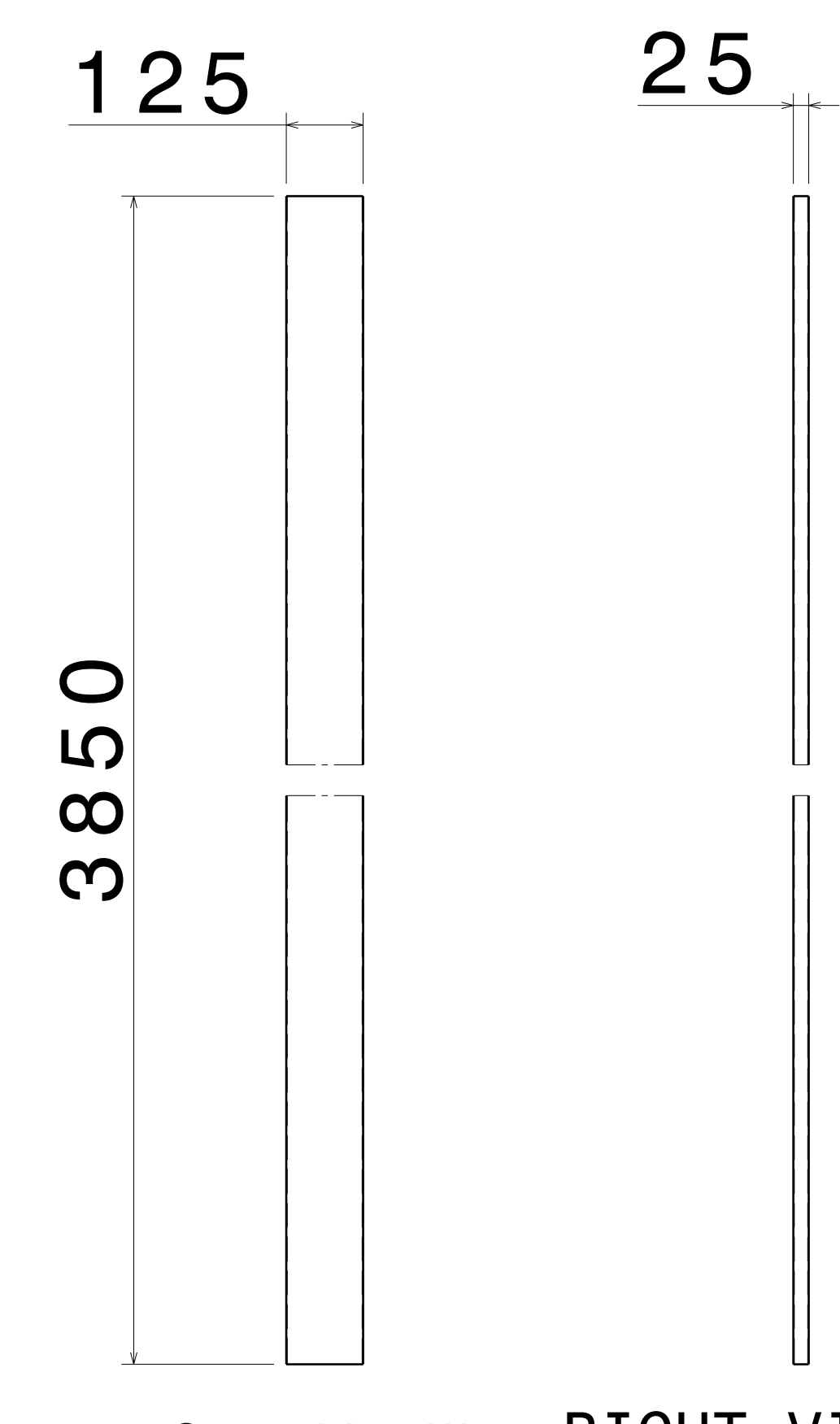

FRONT VIEW RIGHT VIEW
SCALE: 1:10 SCALE: 1:10
ITEM 5, RHS PLANK 2
THICKNESS - 1.6 MM

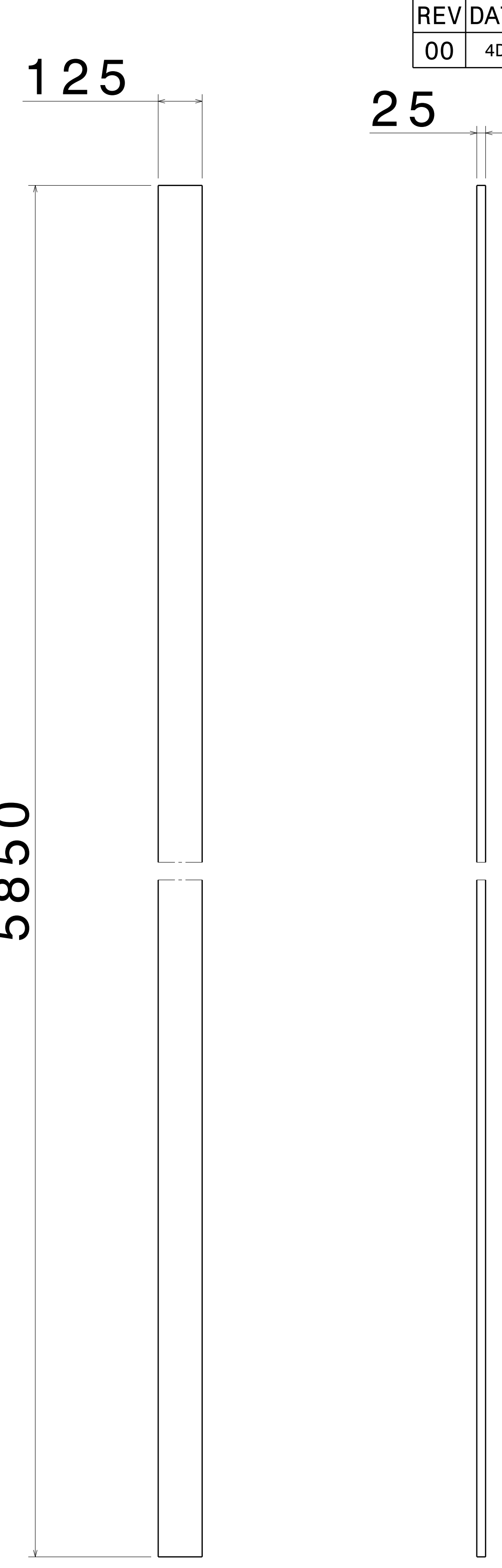

FRONT VIEW RIGHT VIEW
SCALE: 1:10 SCALE: 1:10
ITEM 6, RHS PLANK 3
THICKNESS - 1.6 MM

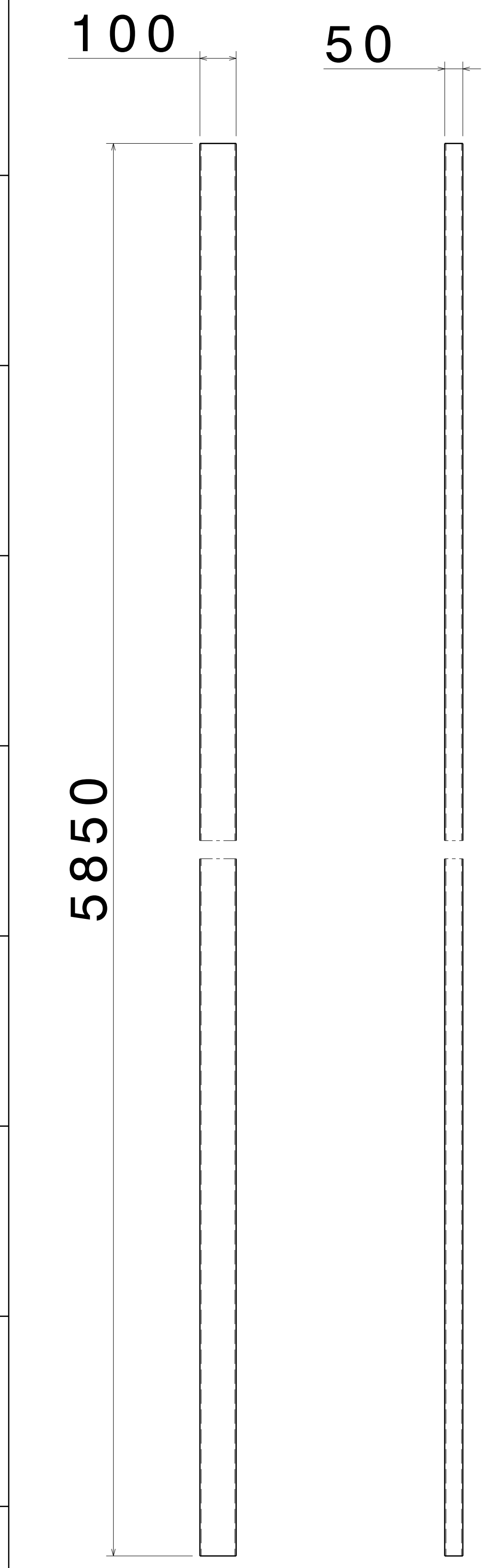

FRONT VIEW RIGHT VIEW
SCALE: 1:10 SCALE: 1:10
ITEM 7, RHS FRAME 1
THICKNESS - 3.6 MM

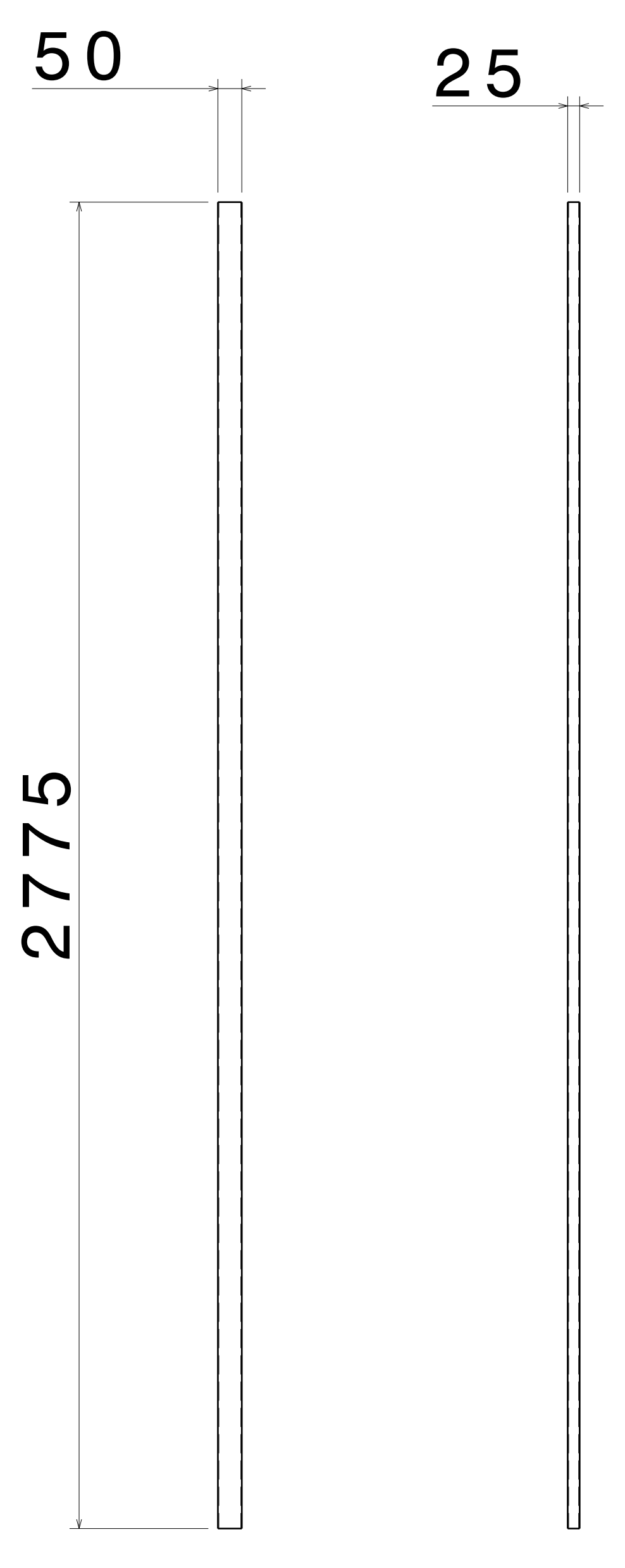

FRONT VIEW RIGHT VIEW
SCALE: 1:10 SCALE: 1:10
ITEM 8, RHS FRAME 2
THICKNESS - 2.0 MM

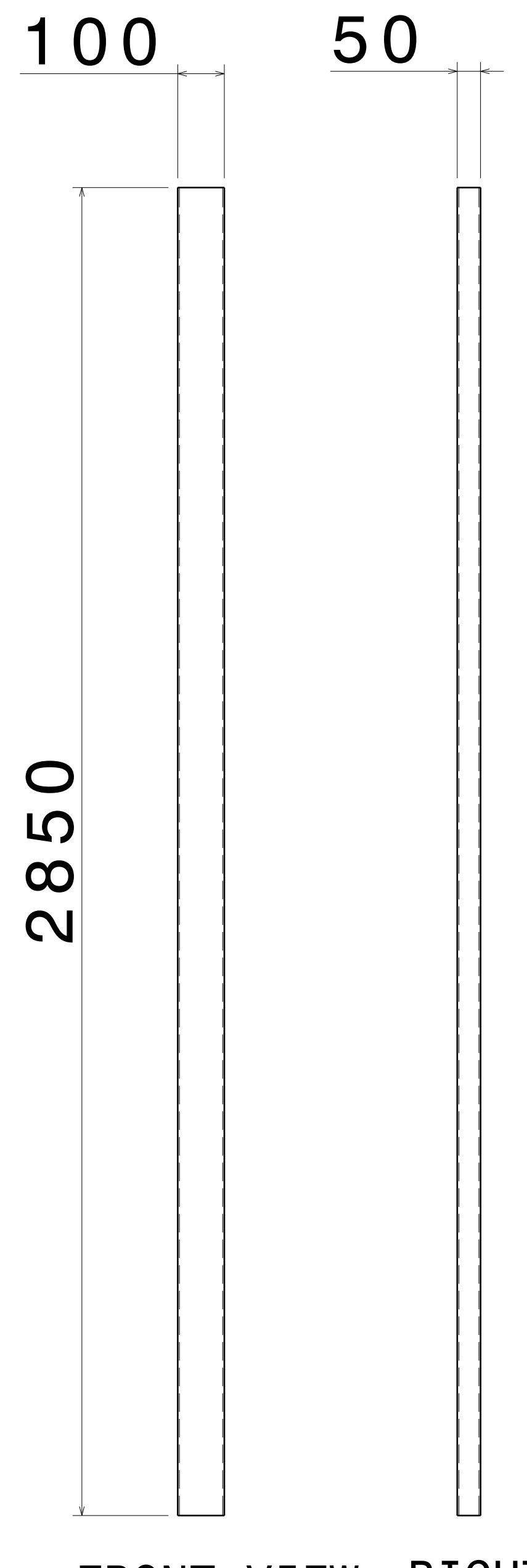

FRONT VIEW RIGHT VIEW
SCALE: 1:10 SCALE: 1:10
ITEM 9, RHS FRAME 3
THICKNESS - 3.6 MM

UNLESS OTHERWISE SPECIFIED DIMENSION ARE IN MM
VIEWS: THIRD ANGLE PROJECTION

This drawing is our property. It can't be reproduced or communicated without our written agreement.		APL APOLLO TUBES LTD.	
DRAWN BY SB		DATE 4DEC2020	
CHECKED BY P2P Analysis & Solutions		DATE 4DEC2020	
DESIGNED BY P2P Analysis & Solutions		DATE 4DEC2020	
DRAWING TITLE DEC 20_9		SIZE A0	DRAWING NUMBER P2P DEC 20_9
SCALE NONE		WEIGHT (kg) XXX	REV 00
		SHEET 3 OF 3	