

REV	DATE	DESCRIPTION
00	25FEB2021	INITIAL REVISION

- NOTES:
- (⊥) ALL VERTICAL SUPPORTS ARE PERPENDICULAR.
  - FLATNESS OF .5MM IS APPLIED BY DEFAULT.
  - ⊞ WELD BEAD OF 2MM RADIUS IS FOLLOWED.
  - ▽▽ SURFACE FINISH MEDIUM TO SMOOTH IS USED.
  - ALL TUBES ARE AS PER APL APOLLO STANDARD. CHANGES MAY EFFECT THE LOAD CAPACITY.
  - ALL HORIZONTAL AND VERTICAL TUBES ARE PERPENDICULAR TO EACH OTHER WITH ±1 DEG.
  - FINE WELDING IS REQUIRED AS PER MENTIONED DETAILS AND FINISHING.
  - HIGHER CURRENT WELDING MAY AFFECT THE BRITTLENESS OF MATERIAL WHICH LATER MAY RAISE TO WEAKENING OF STRUCTURE.
  - FABRICATORS ARE ALLOWED TO USE FITTINGS/FRAMES/SUPPORTS AS NEEDED AND THE SAME MUST BE COMMUNICATED BACK TO ENGINEERING TEAM.
  - BOP COMPONENT WEIGHTS ARE FOR REFERENCE ONLY AND SUBJECTED TO CHANGE PER PURCHASED COMPONENTS.

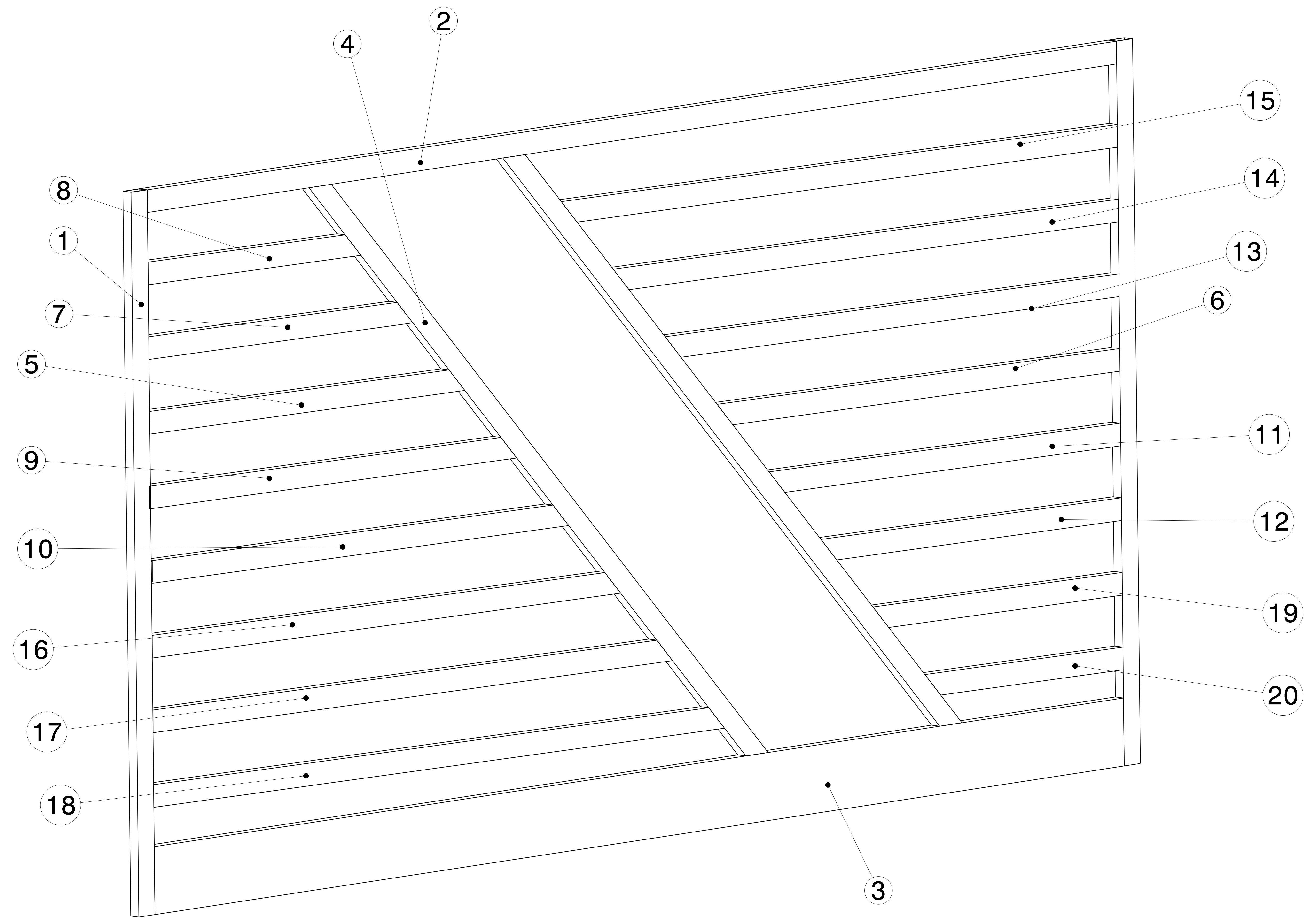

Isometric view  
Scale: 1:4

ITEM NO.	PART NUMBER	DESCRIPTION	QTY.	Wt (kg)/Each
20	RHS FRAME 20	50 X 25 X 2 X 615	1	1.30
19	RHS FRAME 19	50 X 25 X 2 X 775	1	1.70
18	RHS FRAME 18	50 X 25 X 2 X 1770	1	3.90
17	RHS FRAME 17	50 X 25 X 2 X 1610	1	3.50
16	RHS FRAME 16	50 X 25 X 2 X 1450	1	3.20
15	RHS FRAME 15	50 X 25 X 2 X 1722	1	3.80
14	RHS FRAME 14	50 X 25 X 2 X 1565	1	3.45
13	RHS FRAME 13	50 X 25 X 2 X 1410	1	3.00
12	RHS FRAME 12	50 X 25 X 2 X 930	1	2.00
11	RHS FRAME 11	50 X 25 X 2 X 1090	1	2.40
10	RHS FRAME 10	50 X 25 X 2 X 1290	1	2.80
9	RHS FRAME 9	50 X 25 X 2 X 1140	1	2.50
8	RHS FRAME 8	50 X 25 X 2 X 660	1	1.40
7	RHS FRAME 7	50 X 25 X 2 X 820	1	1.80
6	RHS FRAME 6	50 X 25 X 2 X 1250	1	2.75
5	RHS FRAME 5	50 X 25 X 2 X 980	1	2.15
4	RHS FRAME 4	50 X 25 X 2 X 1980	2	3.50
3	RHS FRAME 3	150 X 25 X 2 X 3000	1	16.13
2	RHS FRAME 2	50 X 25 X 2 X 3000	1	6.70
1	RHS FRAME 1	50 X 25 X 2 X 1600	2	3.60

This drawing is our property. It can't be reproduced or communicated without our written agreement.

**APL APOLLO TUBES LTD.**

DRAWING TITLE: **GATE**

DRAWN BY: RR	DATE: 25FEB2021	SIZE: A0	DRAWING NUMBER: P2P FEB 21-12	REV: 00
CHECKED BY: P2P Analysis & Solutions	DATE: 25FEB2021	SCALE: As Indicated	WEIGHT (kg): 0kg	SHEET 1 OF 3
DESIGNED BY: P2P Analysis & Solutions	DATE: 25FEB2021			

UNLESS OTHERWISE SPECIFIED DIMENSION ARE IN MM  
VIEWS: THIRD ANGLE PROJECTION

REV	DATE	DESCRIPTION
00	25FEB2021	INITIAL REVISION

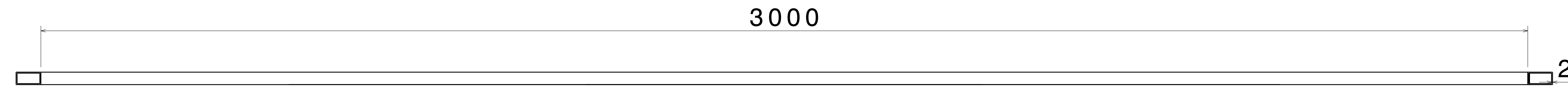

Top view  
Scale: 1:5

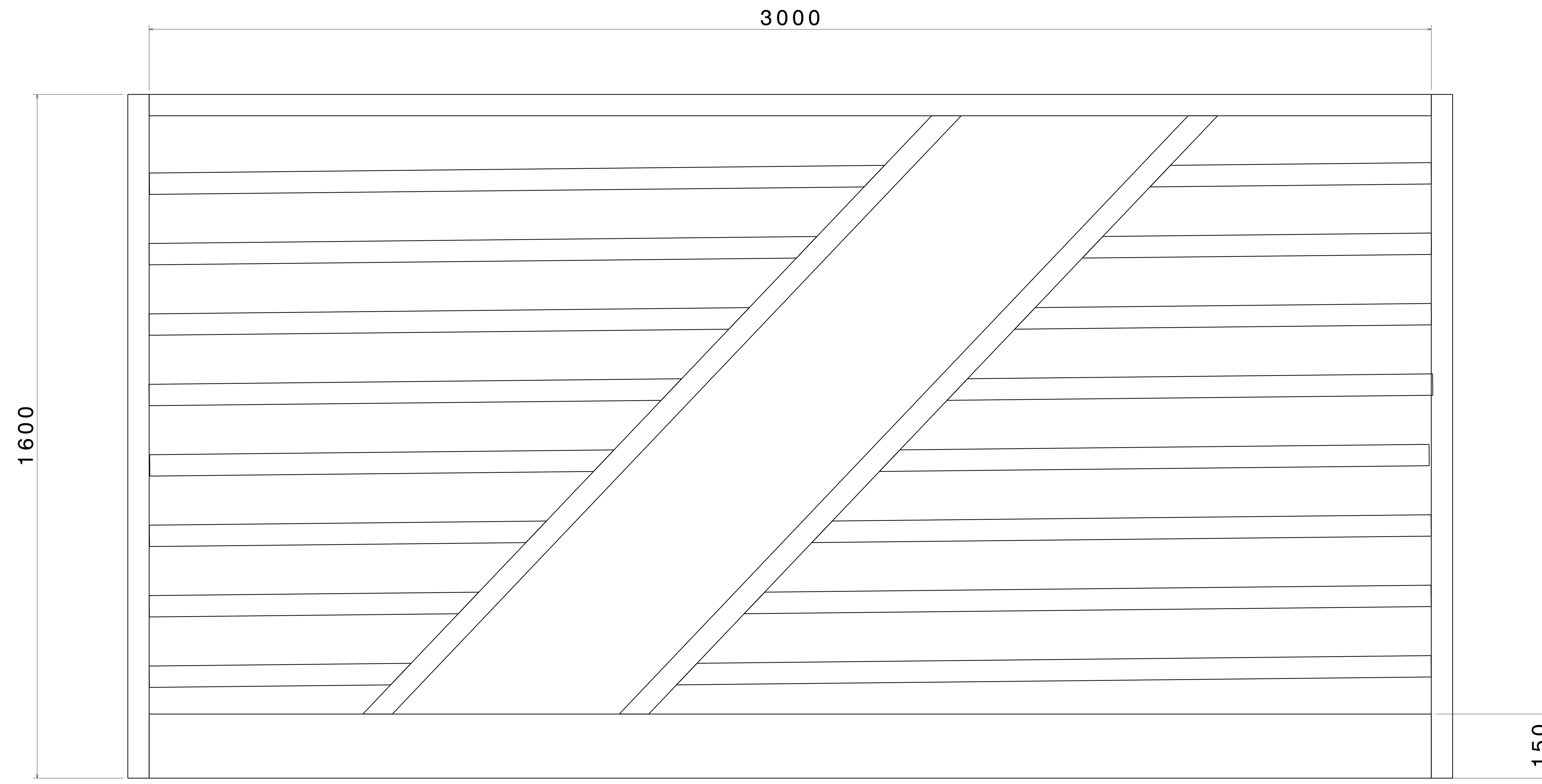

Front view  
Scale: 1:5

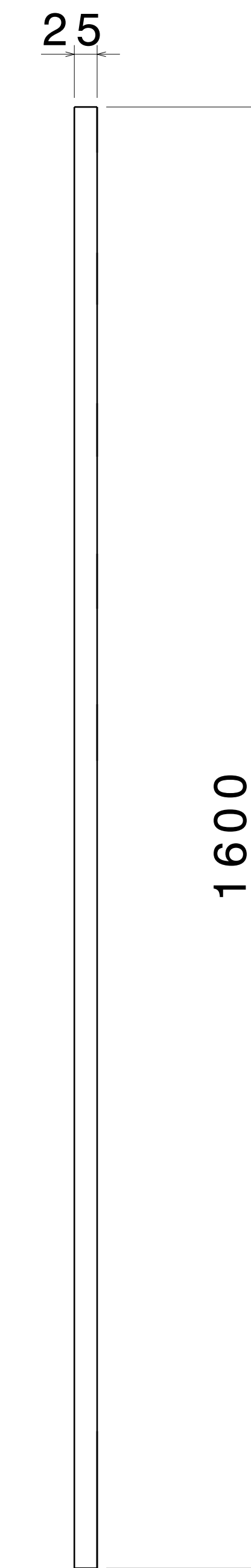

Right view  
Scale: 1:5

UNLESS OTHERWISE SPECIFIED DIMENSION ARE IN MM  
VIEWS: THIRD ANGLE PROJECTION

This drawing is our property. It can't be reproduced or communicated without our written agreement.		APL APOLLO TUBES LTD.	
DRAWN BY SB		DATE 25FEB2021	
CHECKED BY P2P Analysis & Solutions		DATE 25FEB2021	
DESIGNED BY P2P Analysis & Solutions		DATE 25FEB2021	
DRAWING TITLE GATE		SIZE A0	DRAWING NUMBER P2P FEB 21-12
SCALE NONE		WEIGHT (kg) XXX	REV 00
		SHEET 2 OF 3	

REV/DATE	DESCRIPTION
00/25FEB2021	INITIAL REVISION

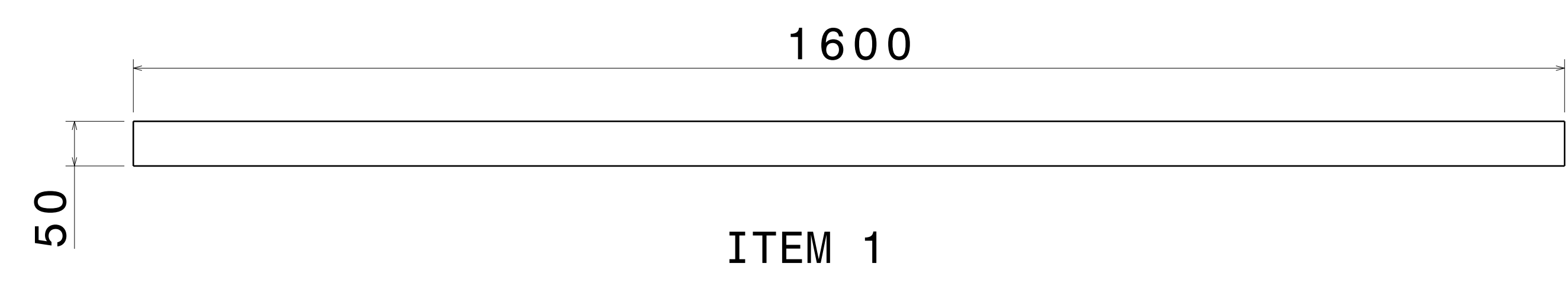

25  
2  
Right view  
Scale: 1:5

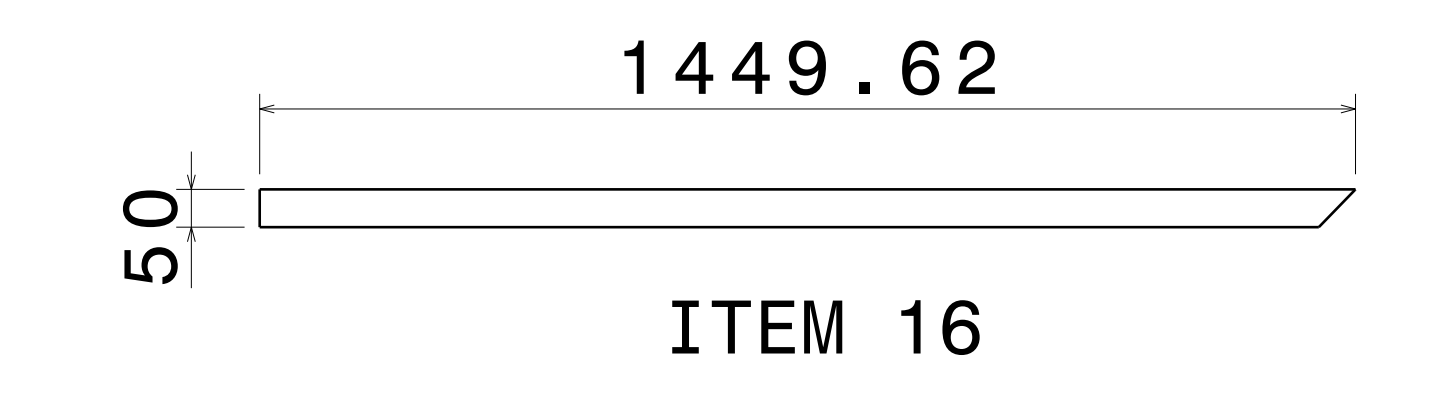

25  
2  
Right view  
Scale: 1:10

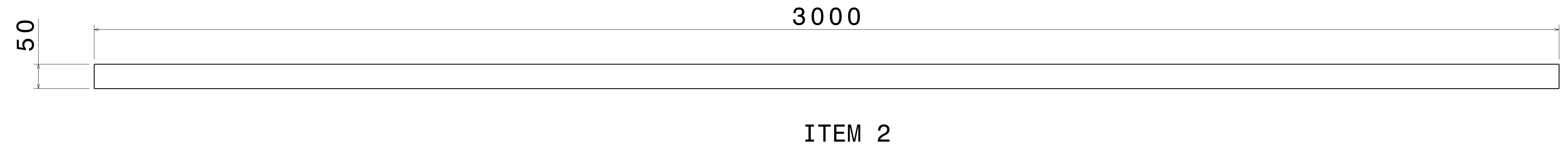

25  
2  
Right view  
Scale: 1:5

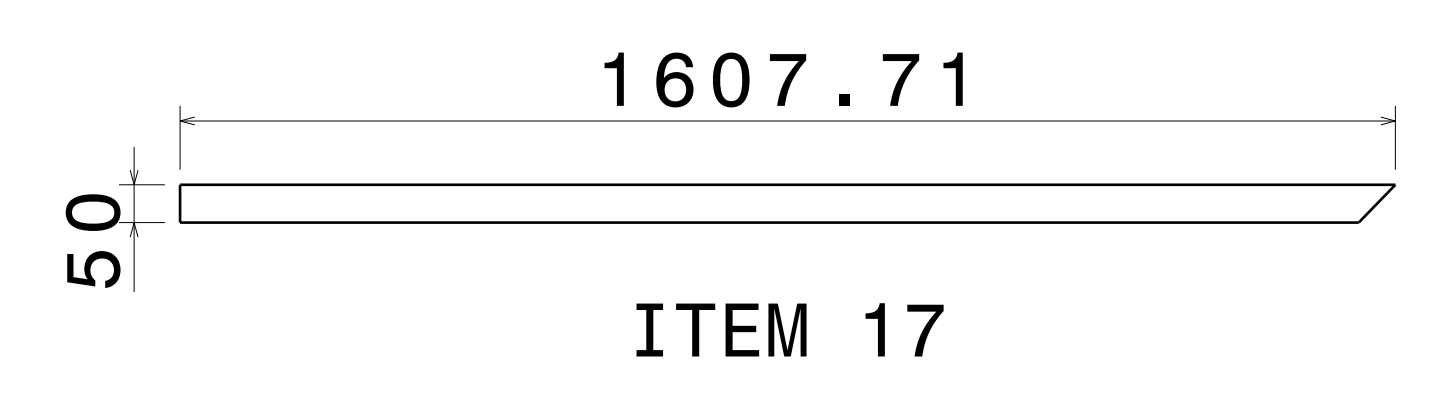

25  
2  
Right view  
Scale: 1:10

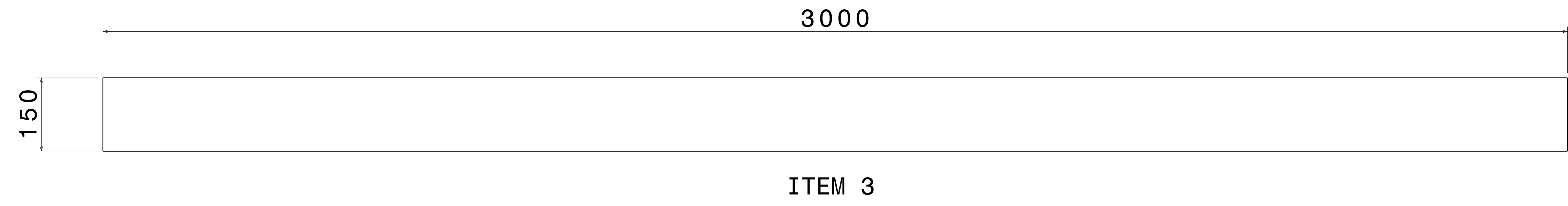

25  
2  
Right view  
Scale: 1:5

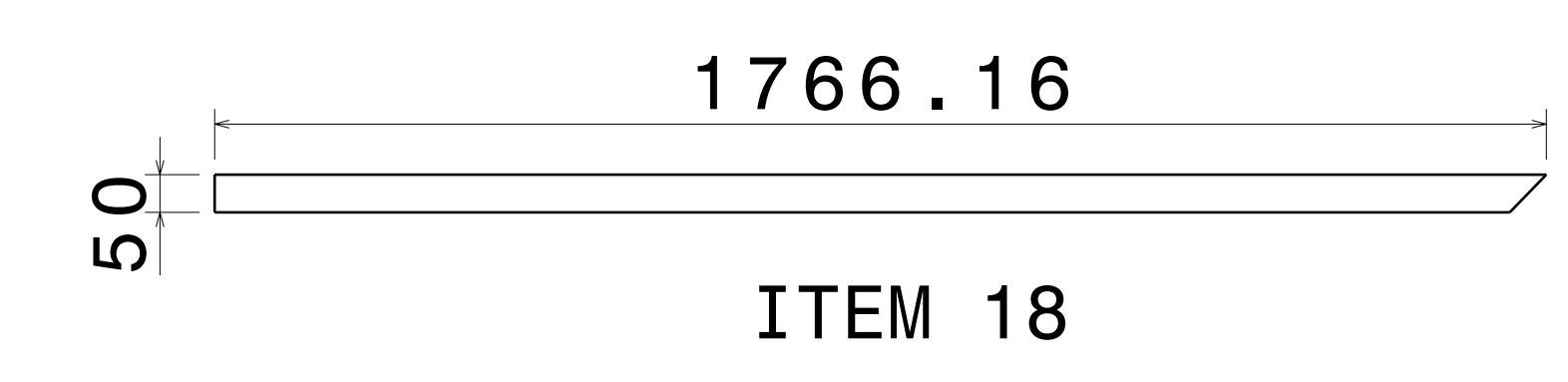

25  
2  
Right view  
Scale: 1:10

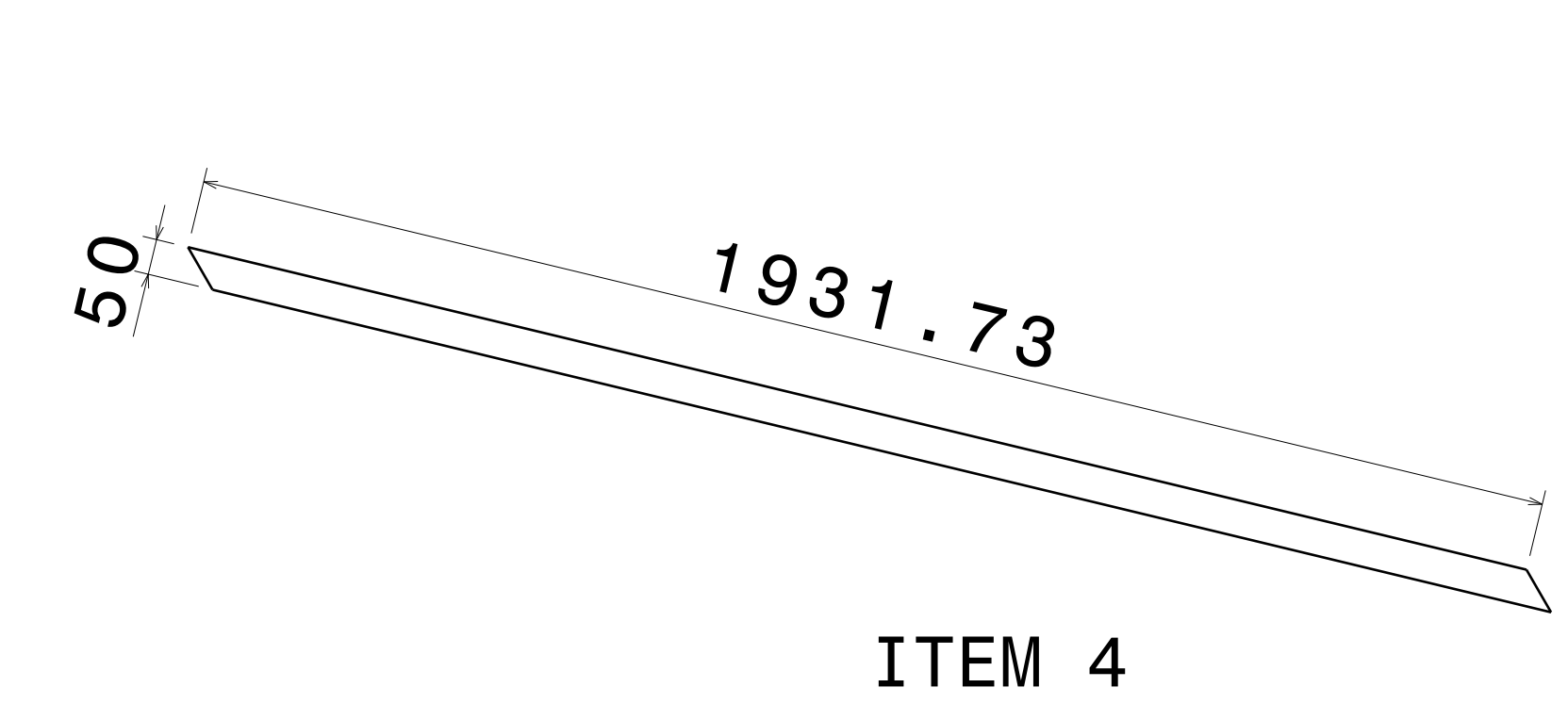

25  
1.6  
Right view  
Scale: 1:10

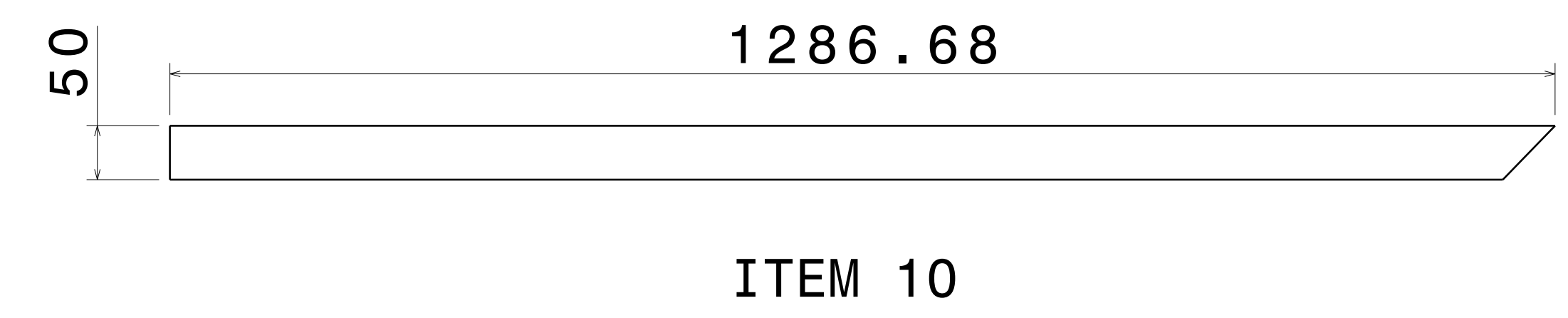

25  
2  
Right view  
Scale: 1:5

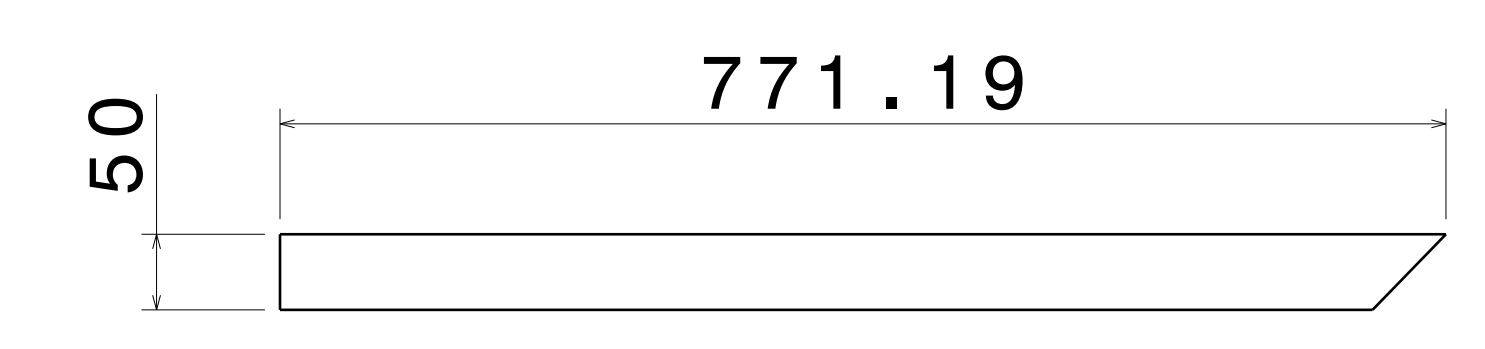

25  
2  
Right view  
Scale: 1:5

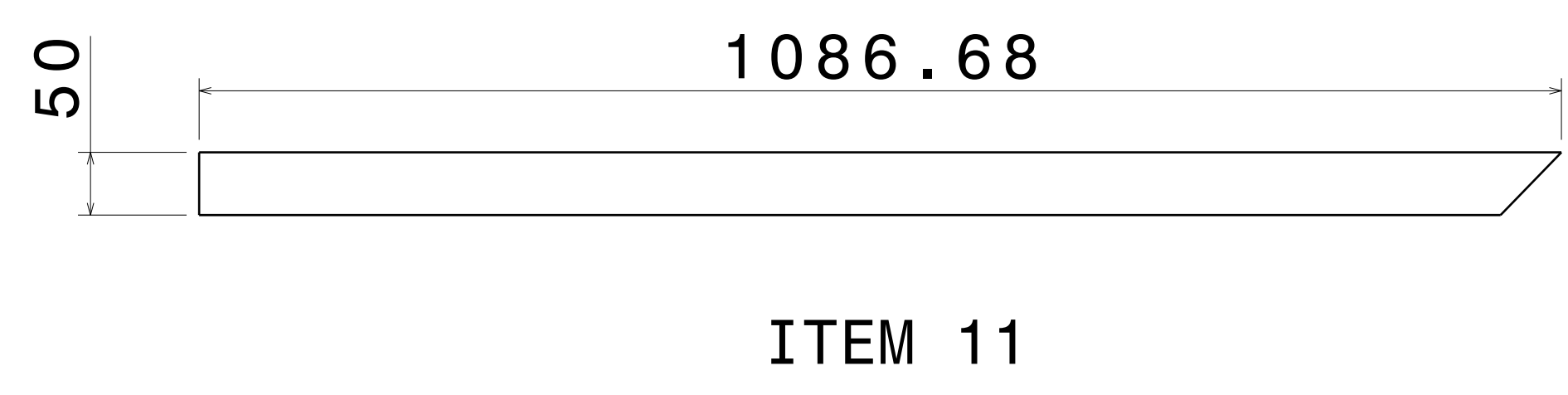

25  
2  
Right view  
Scale: 1:5

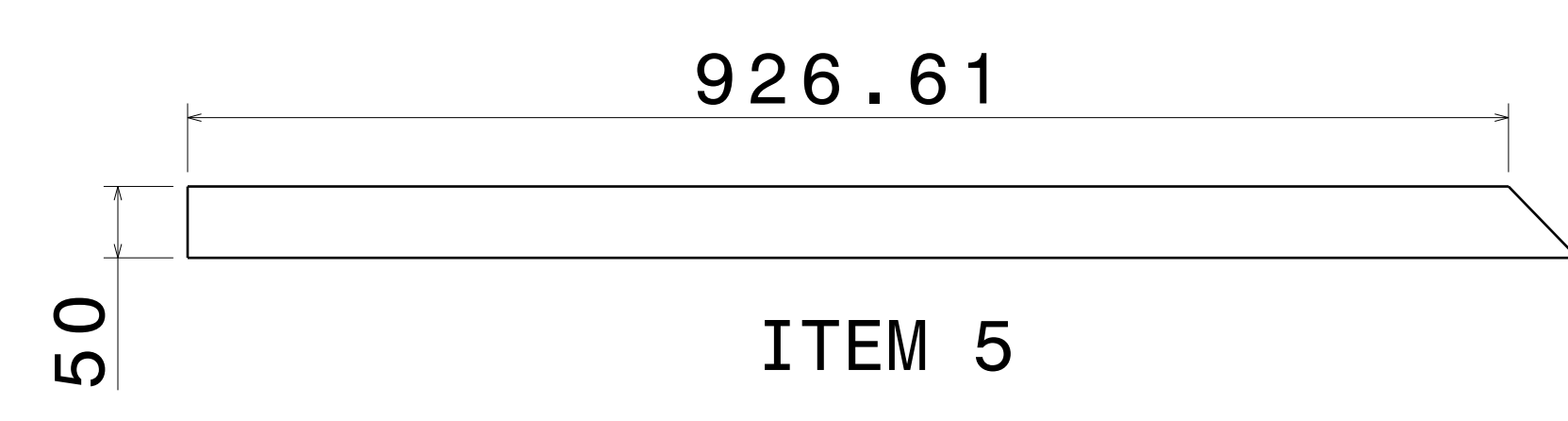

25  
2  
Right view  
Scale: 1:5

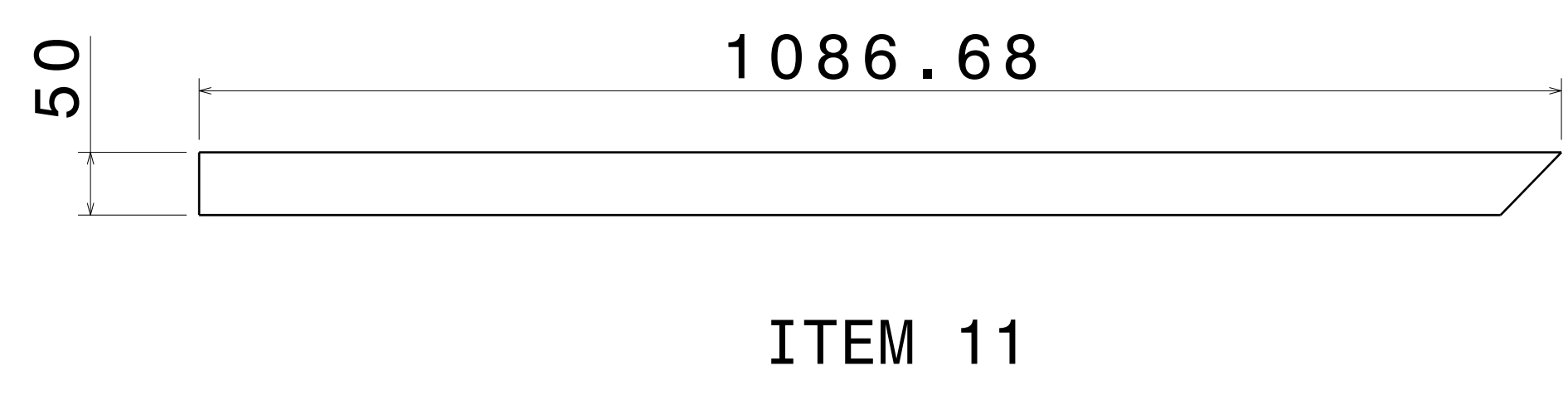

25  
2  
Right view  
Scale: 1:5

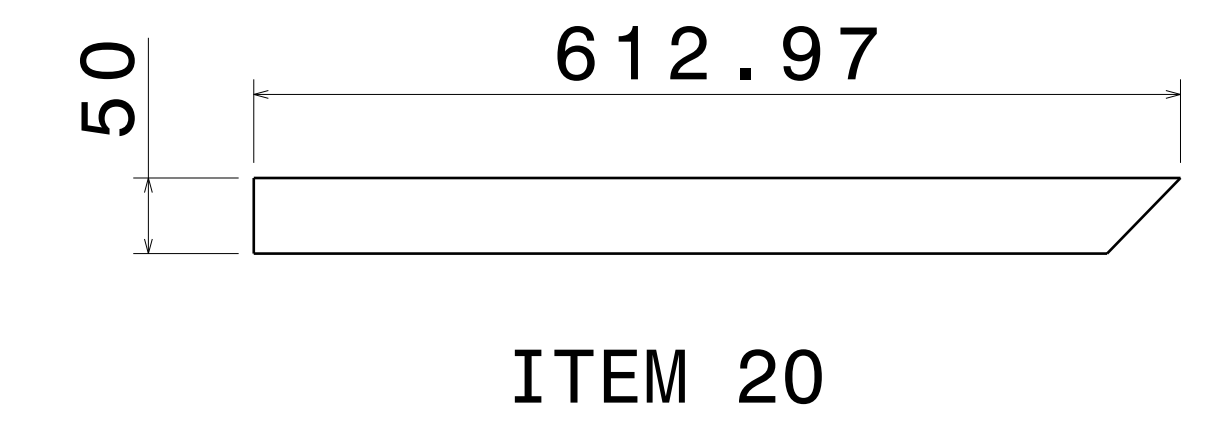

25  
2  
Right view  
Scale: 1:5

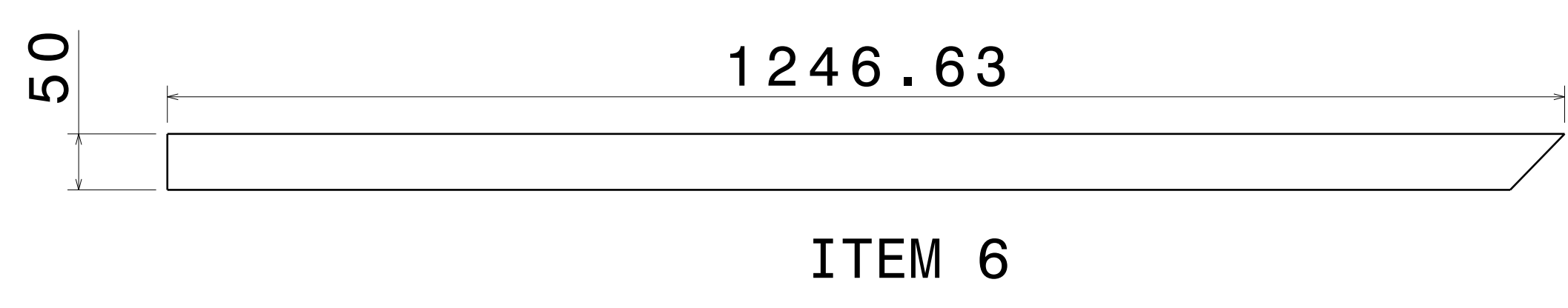

25  
2  
Right view  
Scale: 1:5

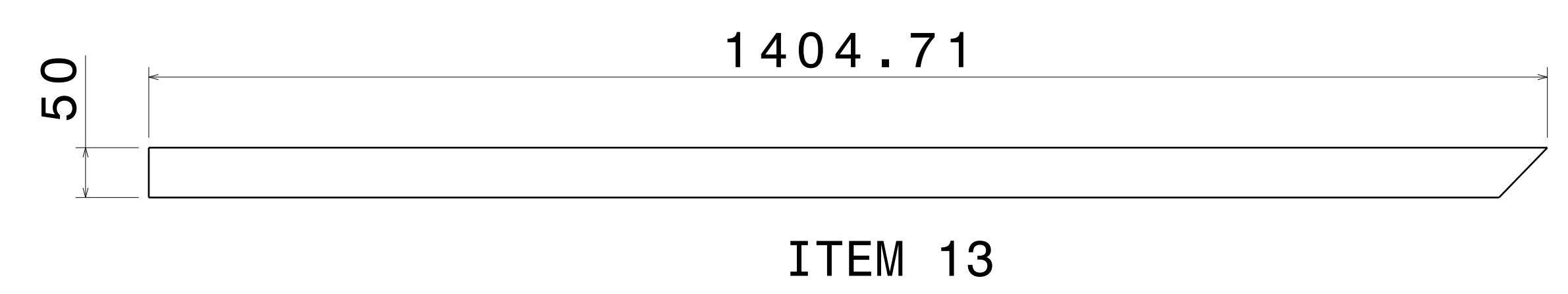

25  
2  
Right view  
Scale: 1:5

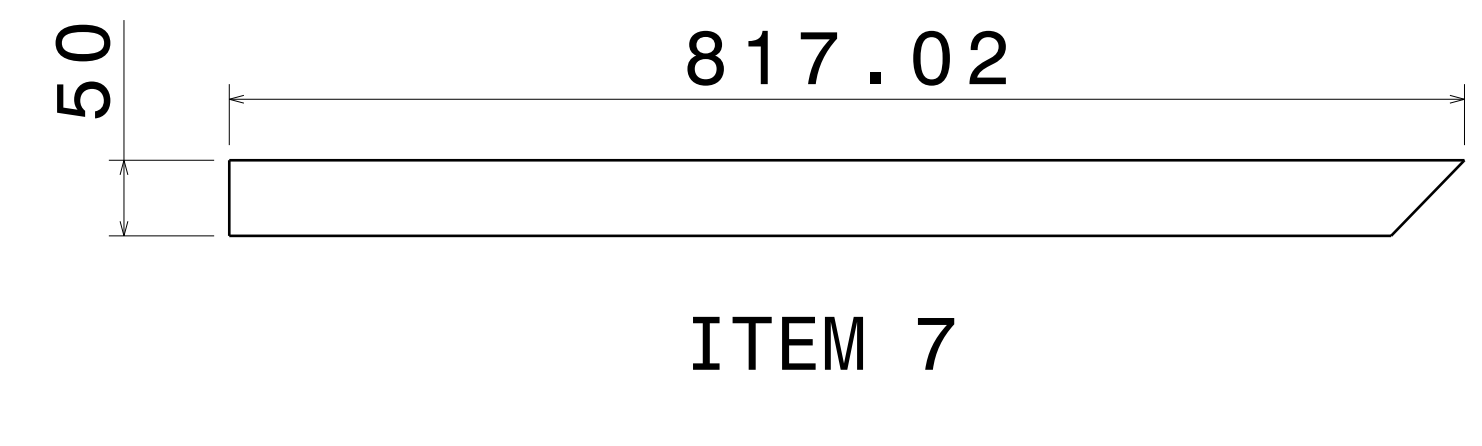

25  
2  
Right view  
Scale: 1:5

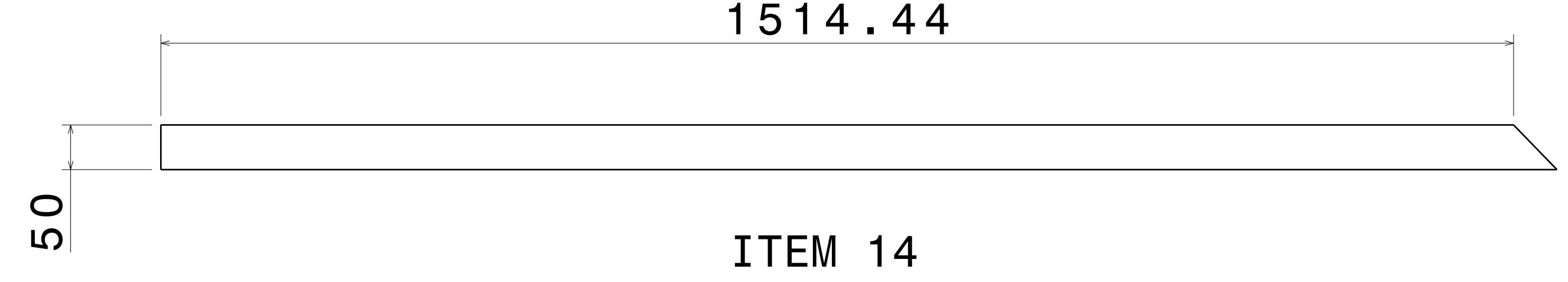

25  
2  
Right view  
Scale: 1:5

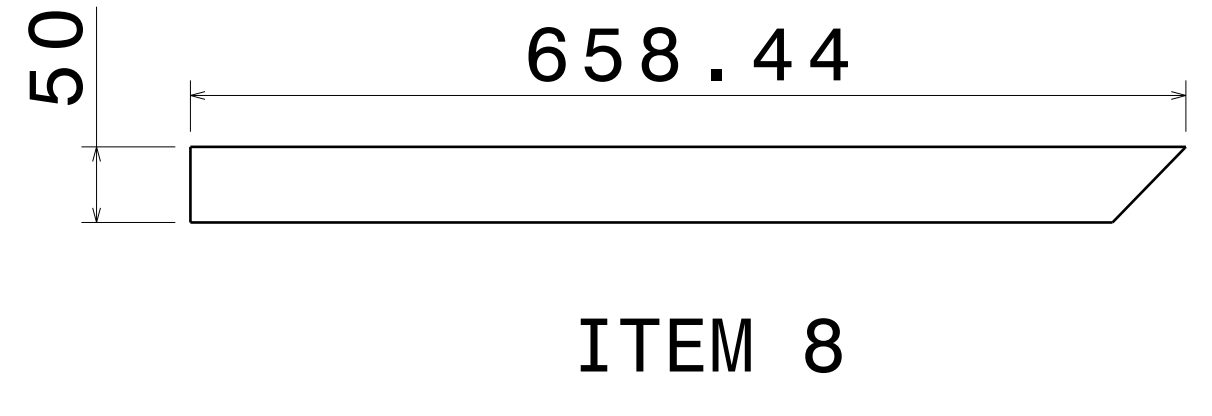

25  
2  
Right view  
Scale: 1:5

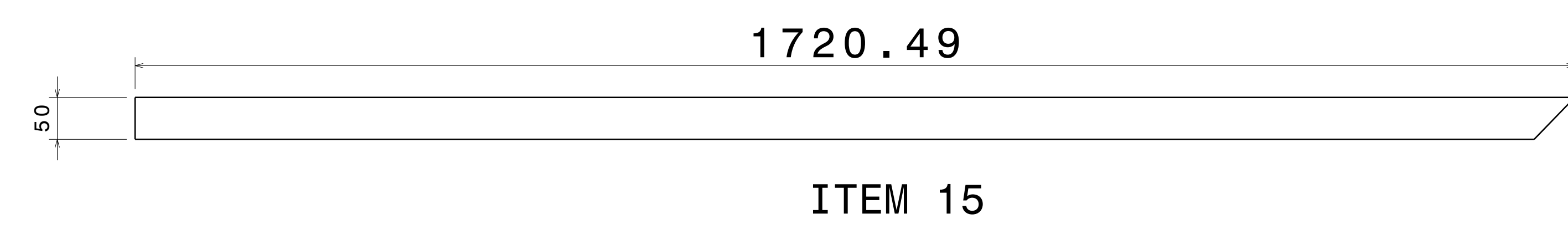

25  
2  
Right view  
Scale: 1:5

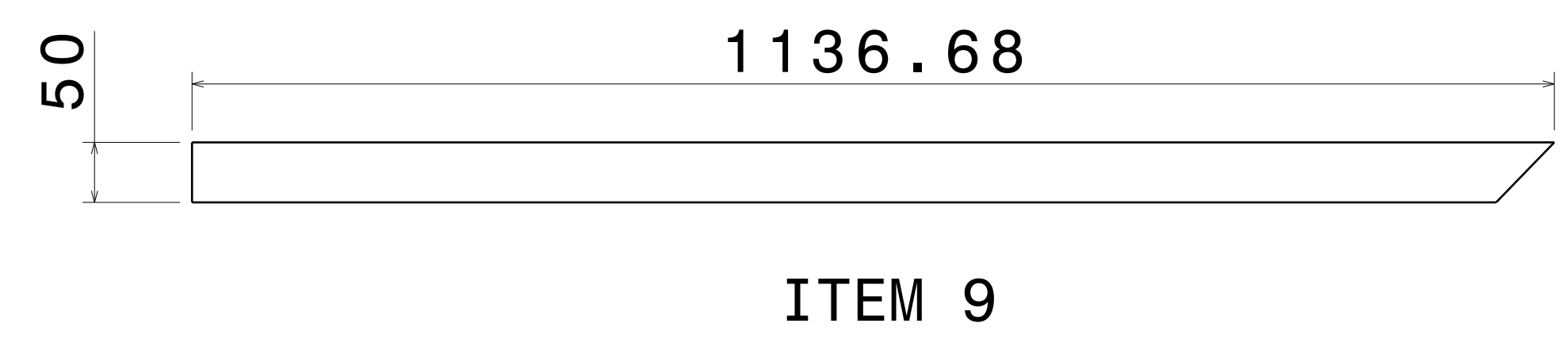

25  
2  
Right view  
Scale: 1:5

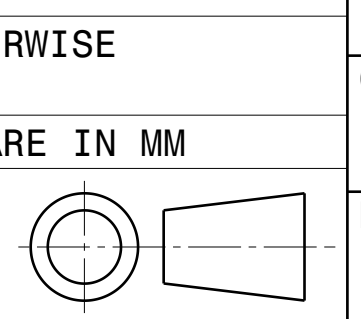
This drawing is our property. It can't be reproduced or communicated without our written agreement.		APL APOLLO TUBES LTD. 	
DRAWN BY SB		DATE 25FEB2021	
CHECKED BY P2P Analysis & Solutions		DATE 25FEB2021	
DESIGNED BY P2P Analysis & Solutions		DATE 25FEB2021	
UNLESS OTHERWISE SPECIFIED DIMENSION ARE IN MM VIEWS: THIRD ANGLE PROJECTION 		DRAWING TITLE GATE	
SIZE A0	DRAWING NUMBER P2P FEB 21-12	REV 00	
SCALE NONE	WEIGHT (kg) XXX	SHEET 3 OF 3	