

| REV/DATE | DESCRIPTION |
|----------------|------------------|
| 00 / 16FEB2021 | INITIAL REVISION |

- NOTES:
- (⊥) ALL VERTICAL SUPPORTS ARE PERPENDICULAR.
 - FLATNESS OF .5MM IS APPLIED BY DEFAULT.
 - ⊲ WELD BEAD OF 2MM RADIUS IS FOLLOWED.
 - ▽▽ SURFACE FINISH MEDIUM TO SMOOTH IS USED.
 - ALL TUBES ARE AS PER APL APOLLO STANDARD. CHANGES MAY EFFECT THE LOAD CAPACITY.
 - ALL HORIZONTAL AND VERTICAL TUBES ARE PERPENDICULAR TO EACH OTHER WITH ±1 DEG.
 - FINE WELDING IS REQUIRED AS PER MENTIONED DETAILS AND FINISHING.
 - HIGHER CURRENT WELDING MAY AFFECT THE BRITTLENESS OF MATERIAL WHICH LATER MAY RAISE TO WEAKENING OF STRUCTURE.
 - FABRICATORS ARE ALLOWED TO USE FITTINGS/FRAMES/SUPPORTS AS NEEDED AND THE SAME MUST BE COMMUNICATED BACK TO ENGINEERING TEAM.
 - BOP COMPONENT WEIGHTS ARE FOR REFERENCE ONLY AND SUBJECTED TO CHANGE PER PURCHASED COMPONENTS.

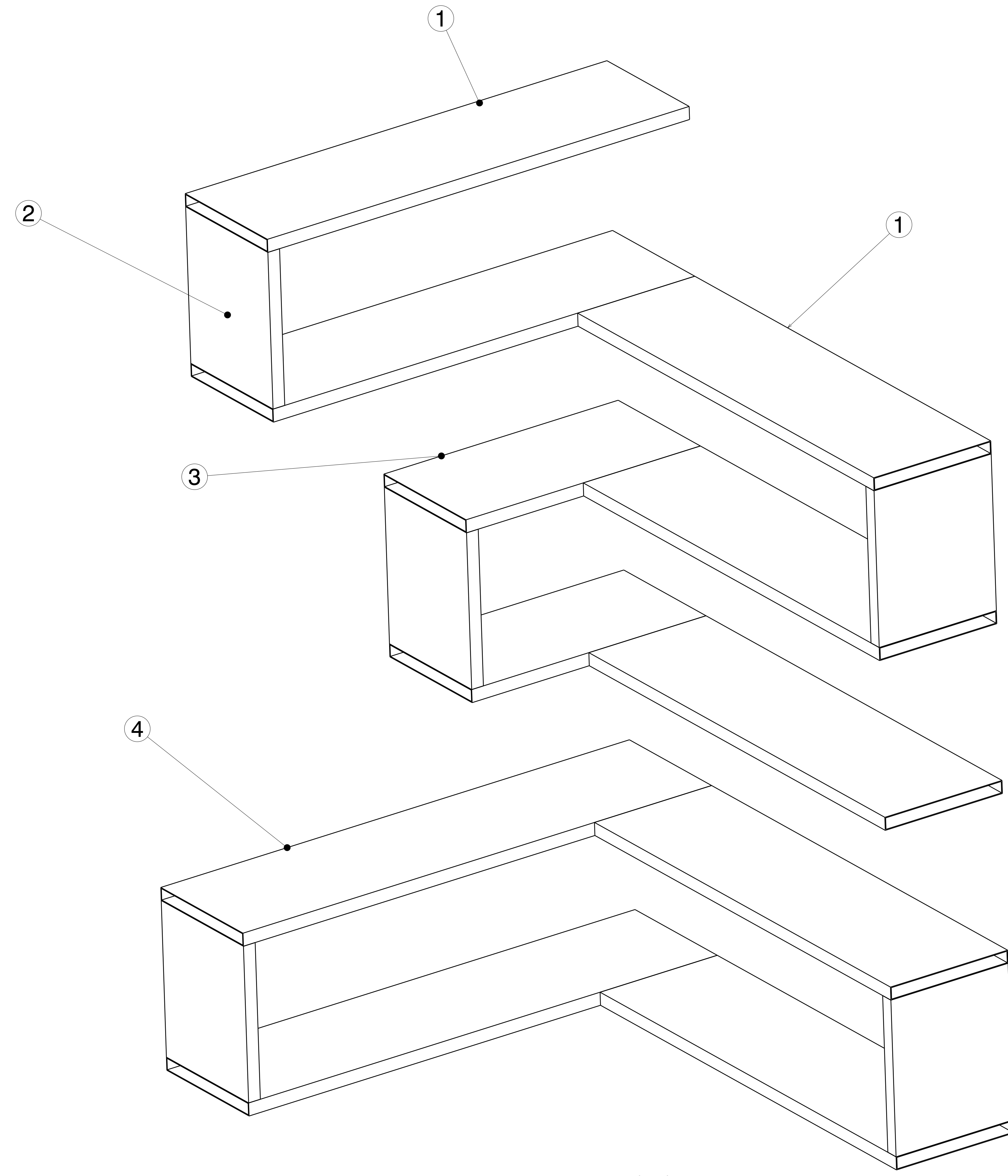

Isometric view
Scale: 1:4

| ITEM NO. | PART NUMBER | DESCRIPTION | QTY. | Wt (Kg) / Each |
|----------|-------------|-----------------------|------|----------------|
| 4 | PLANK 4 | 250 X 25 X 1.6 X 1000 | 2 | 6.83 |
| 3 | PLANK 3 | 250 X 25 X 1.6 X 500 | 5 | 3.42 |
| 2 | PLANK 2 | 250 X 25 X 1.6 X 300 | 5 | 2.05 |
| 1 | PLANK 1 | 250 X 25 X 1.6 X 900 | 7 | 6.15 |

| | | | |
|---|----------------|------------------------------|--|
| This drawing is our property. It can't be reproduced or communicated without our written agreement. | | APL APOLLO TUBES LTD. | |
| DRAWN BY | | DATE | |
| SB | | 16FEB2021 | |
| CHECKED BY | | DATE | |
| P2P Analysis & Solutions | | 16FEB2021 | |
| DESIGNED BY | | DATE | |
| P2P Analysis & Solutions | | 16FEB2021 | |
| DRAWING TITLE | | REV | |
| WINDOWS PHOTO VIEWER | | 00 | |
| SIZE | DRAWING NUMBER | SCALE | |
| A0 | P2P FEB21 - 13 | As Indicated | |
| WEIGHT (kg) | | SHEET 1 OF 3 | |
| 0kg | | | |

UNLESS OTHERWISE SPECIFIED DIMENSION ARE IN MM
VIEWS: THIRD ANGLE PROJECTION

| REV | DATE | DESCRIPTION |
|-----|-----------|------------------|
| 00 | 16FEB2021 | INITIAL REVISION |

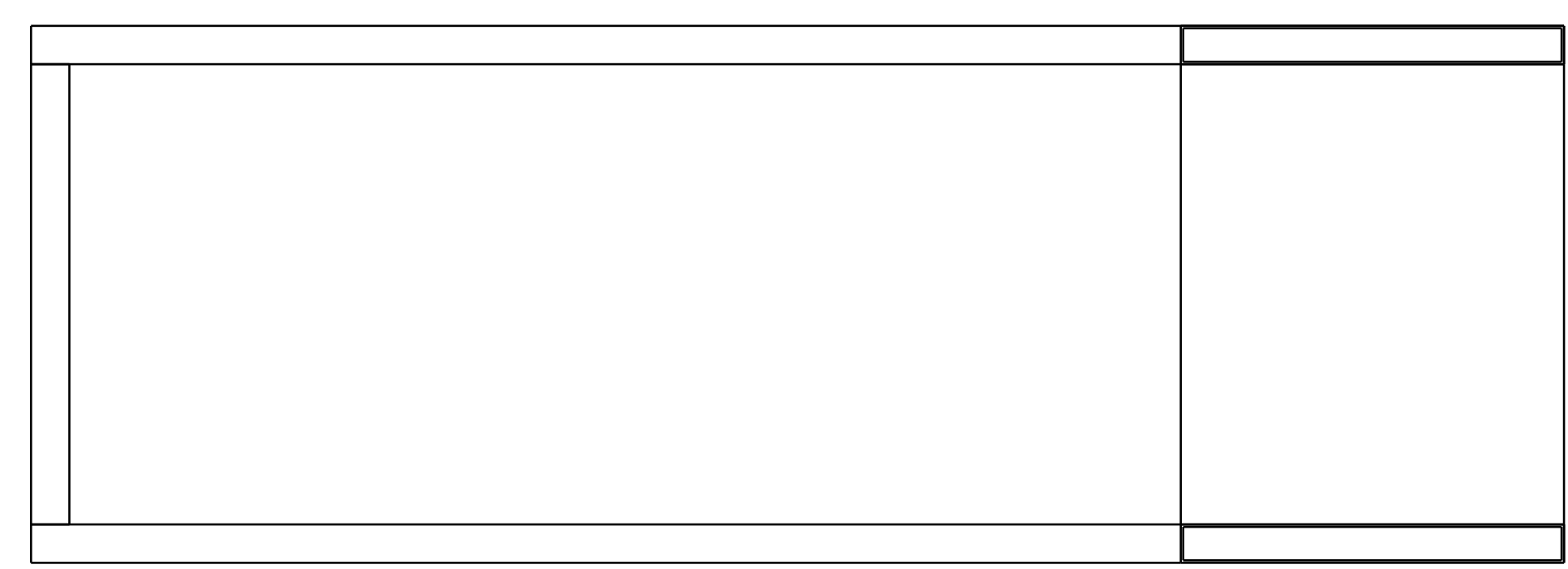
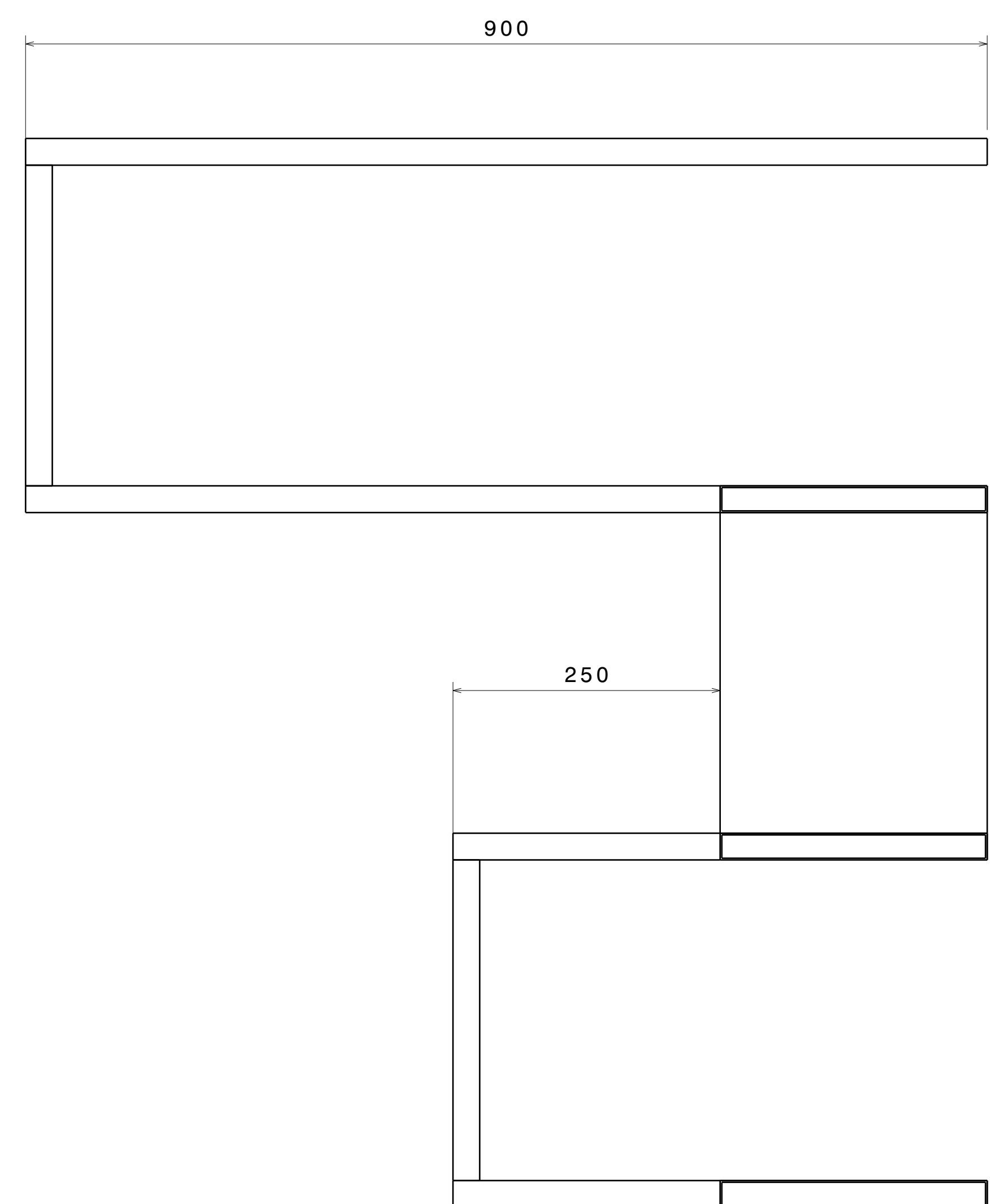
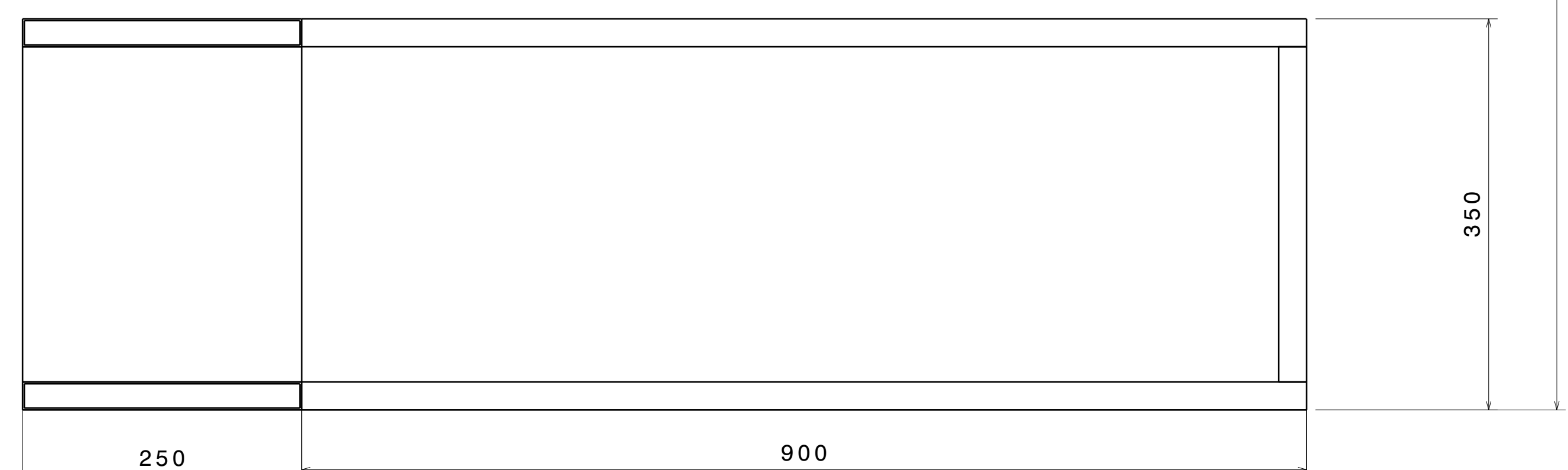
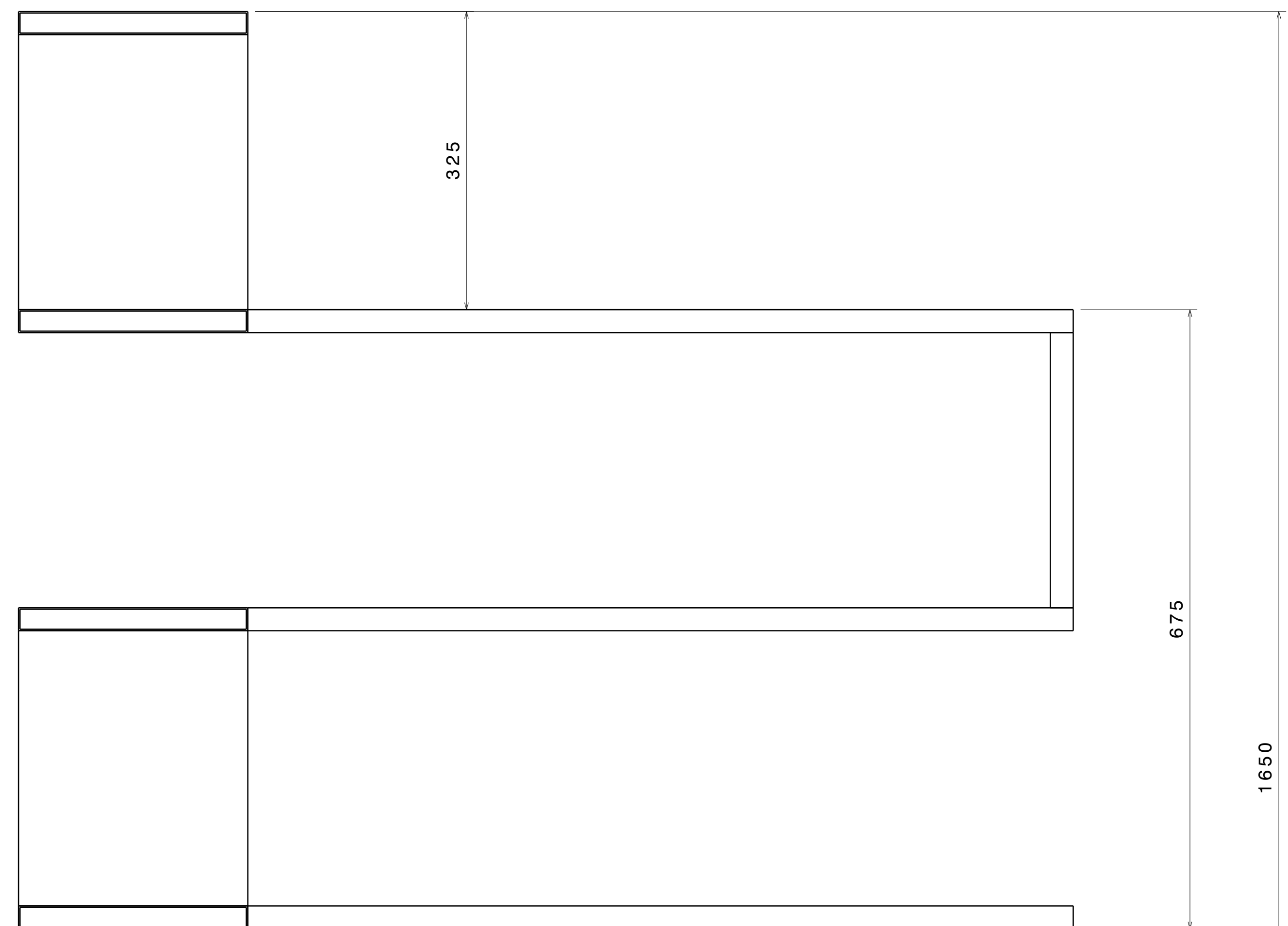
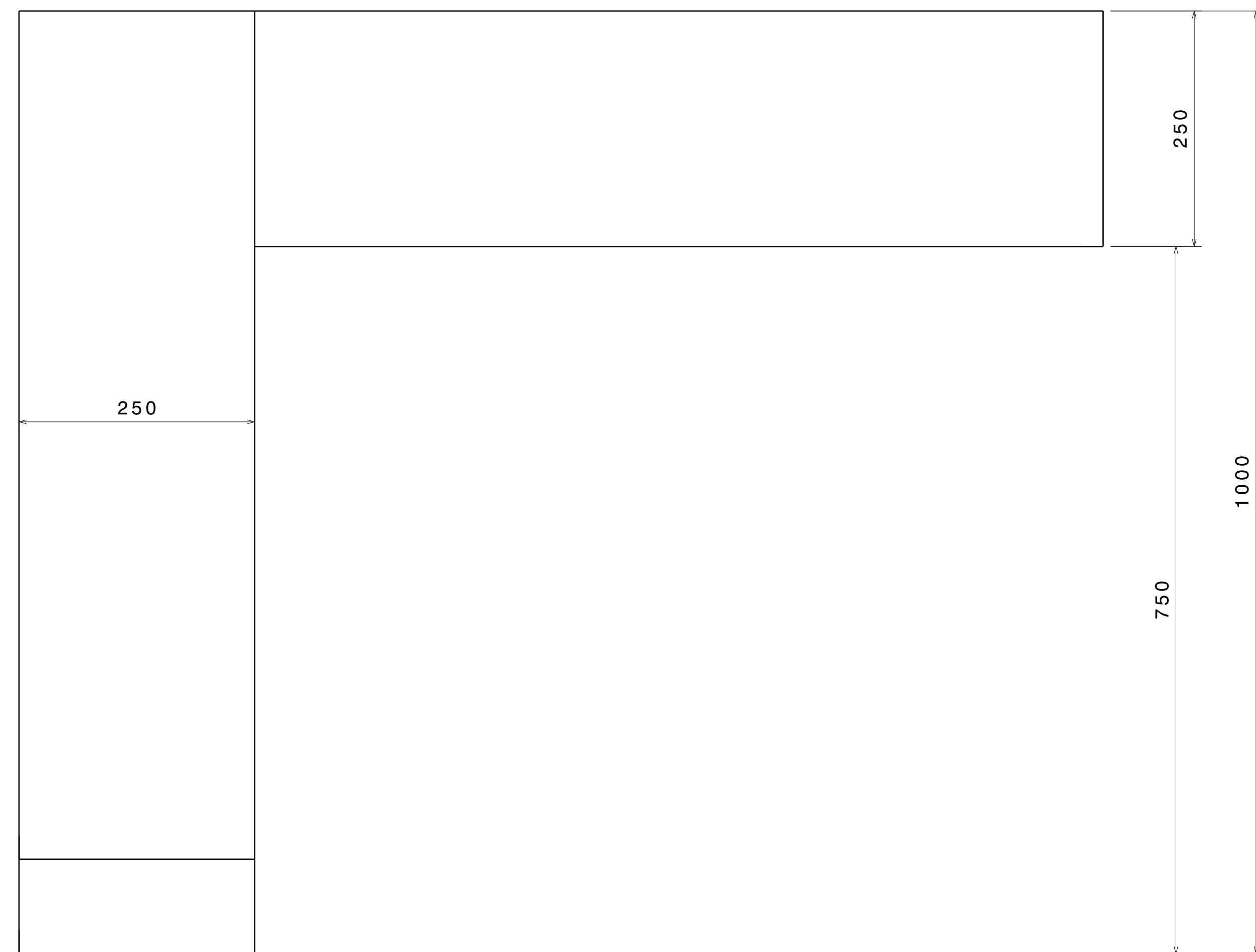

UNLESS OTHERWISE SPECIFIED DIMENSION ARE IN MM
VIEWS: THIRD ANGLE PROJECTION

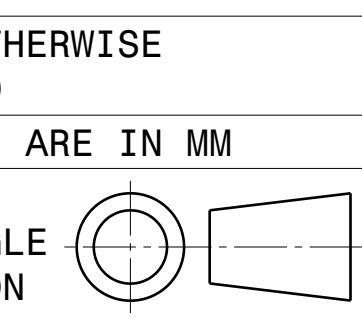

| | | | |
|---|--------------------|---|--------------------------------|
| This drawing is our property. It can't be reproduced or communicated without our written agreement. | | APL APOLLO TUBES LTD.  | |
| DRAWN BY SB | | DATE 16FEB2021 | |
| CHECKED BY P2P Analysis & Solutions | | DATE 16FEB2021 | |
| DESIGNED BY P2P Analysis & Solutions | | DATE 16FEB2021 | |
| DRAWING TITLE WINDOWS PHOTO VIEWER | | SIZE A0 | DRAWING NUMBER P2P_FEB21-13 |
| SCALE NONE | WEIGHT (kg) XXX | REV 00 | SHEET 2 OF 3 |

| REV | DATE | DESCRIPTION |
|-----|-----------|------------------|
| 00 | 16FEB2021 | INITIAL REVISION |

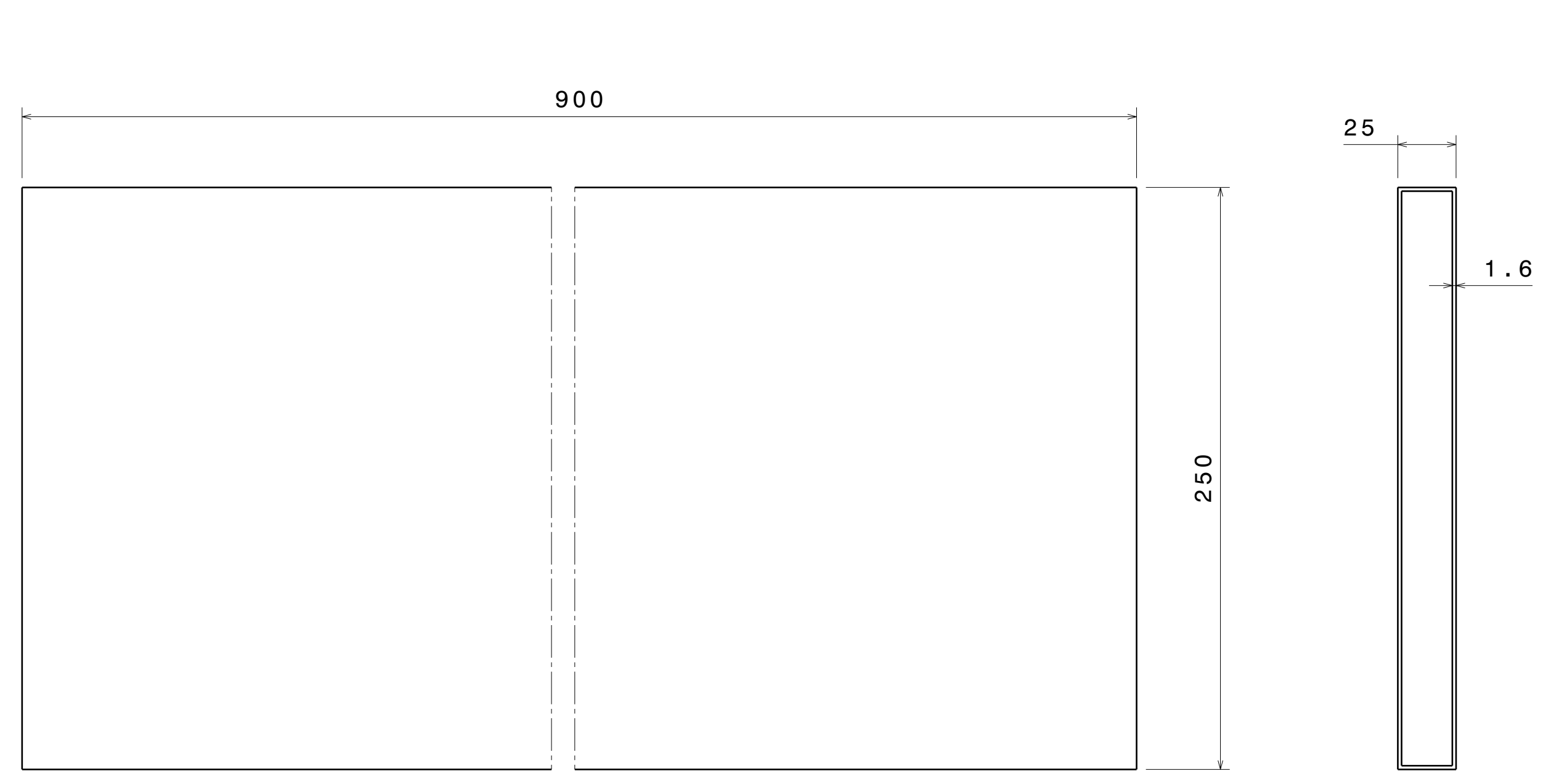

ITEM 1

Right view
Scale: 1:2

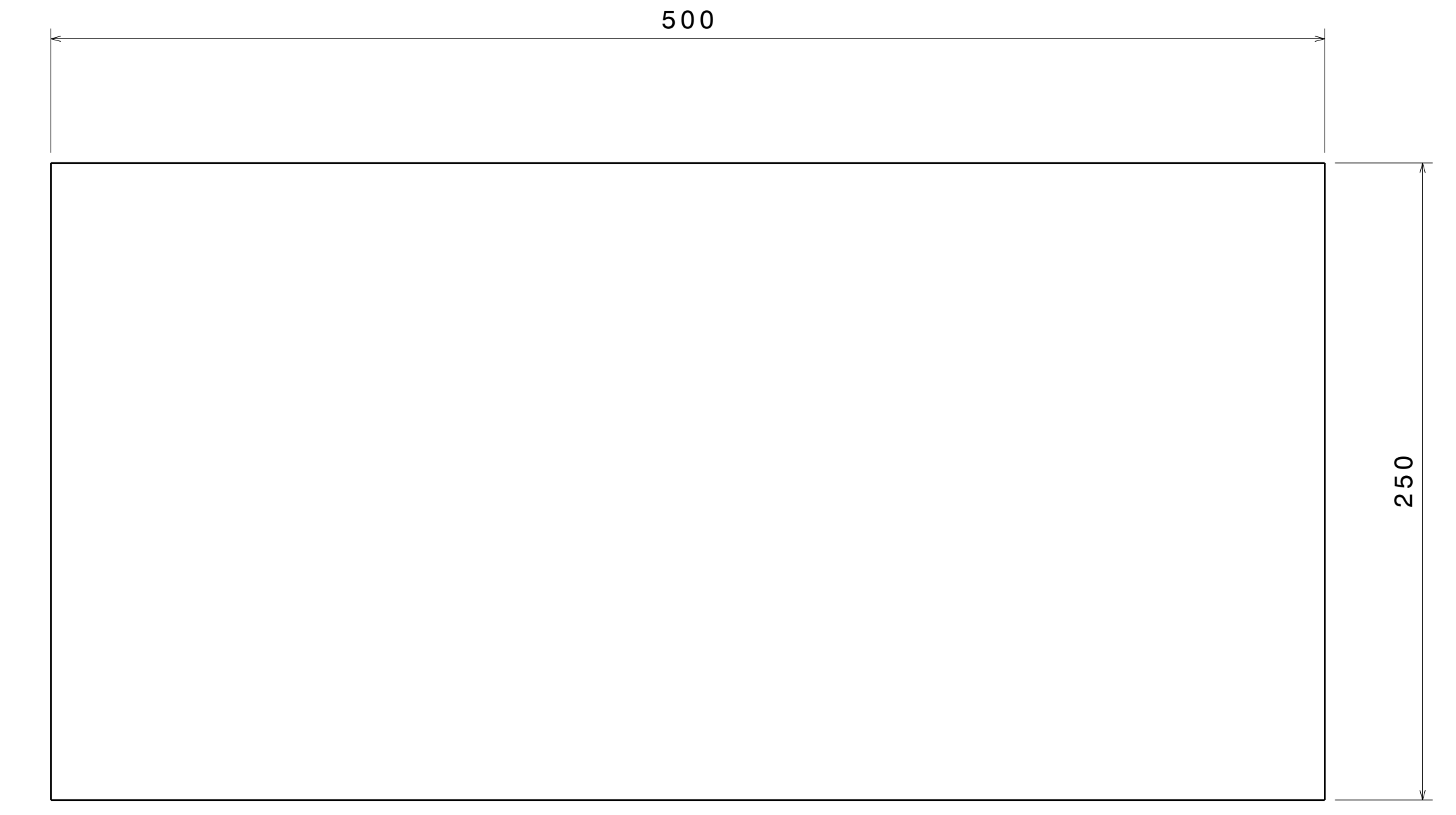

ITEM 3

Right view
Scale: 1:2

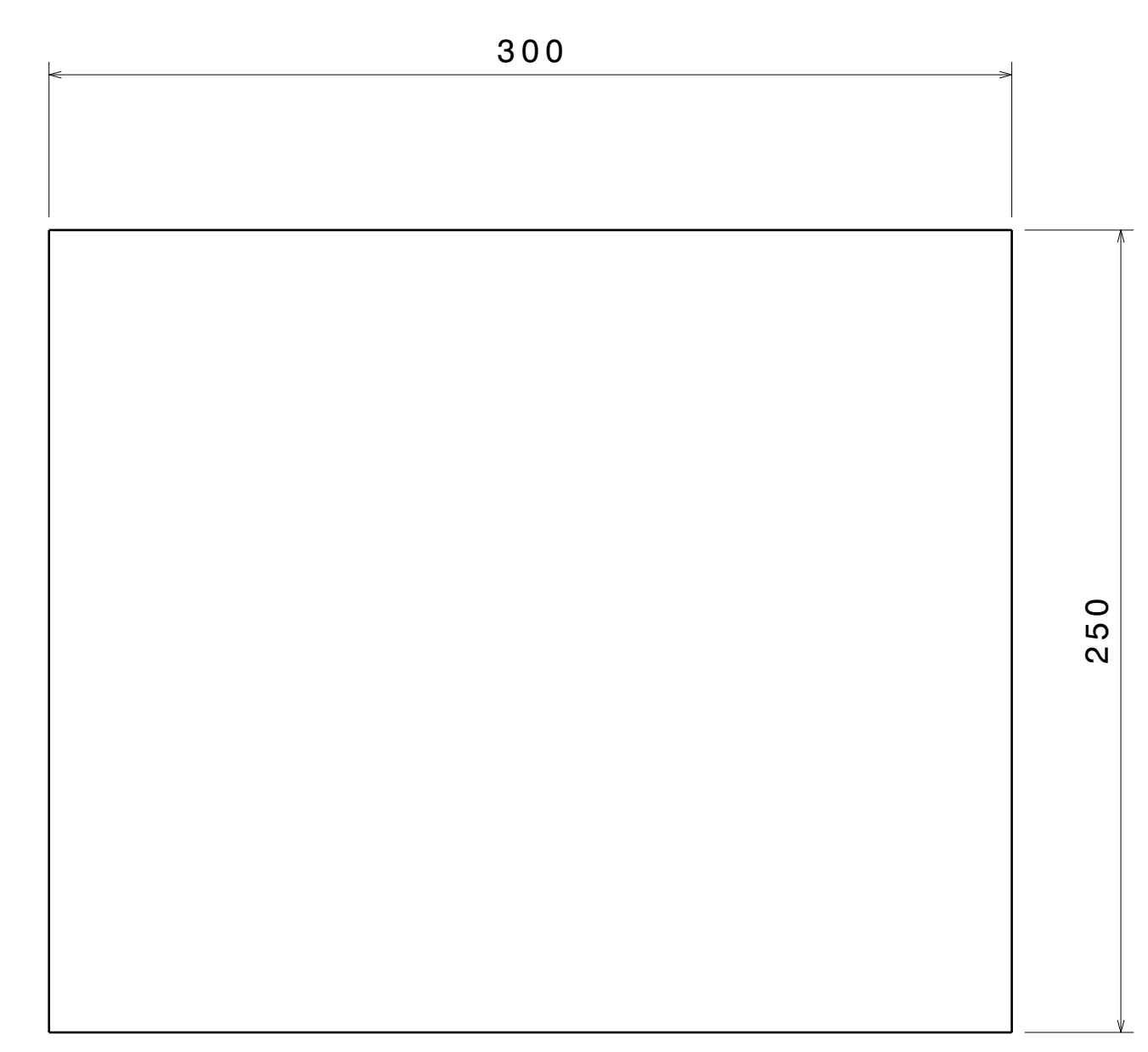

ITEM 2

Right view
Scale: 1:2

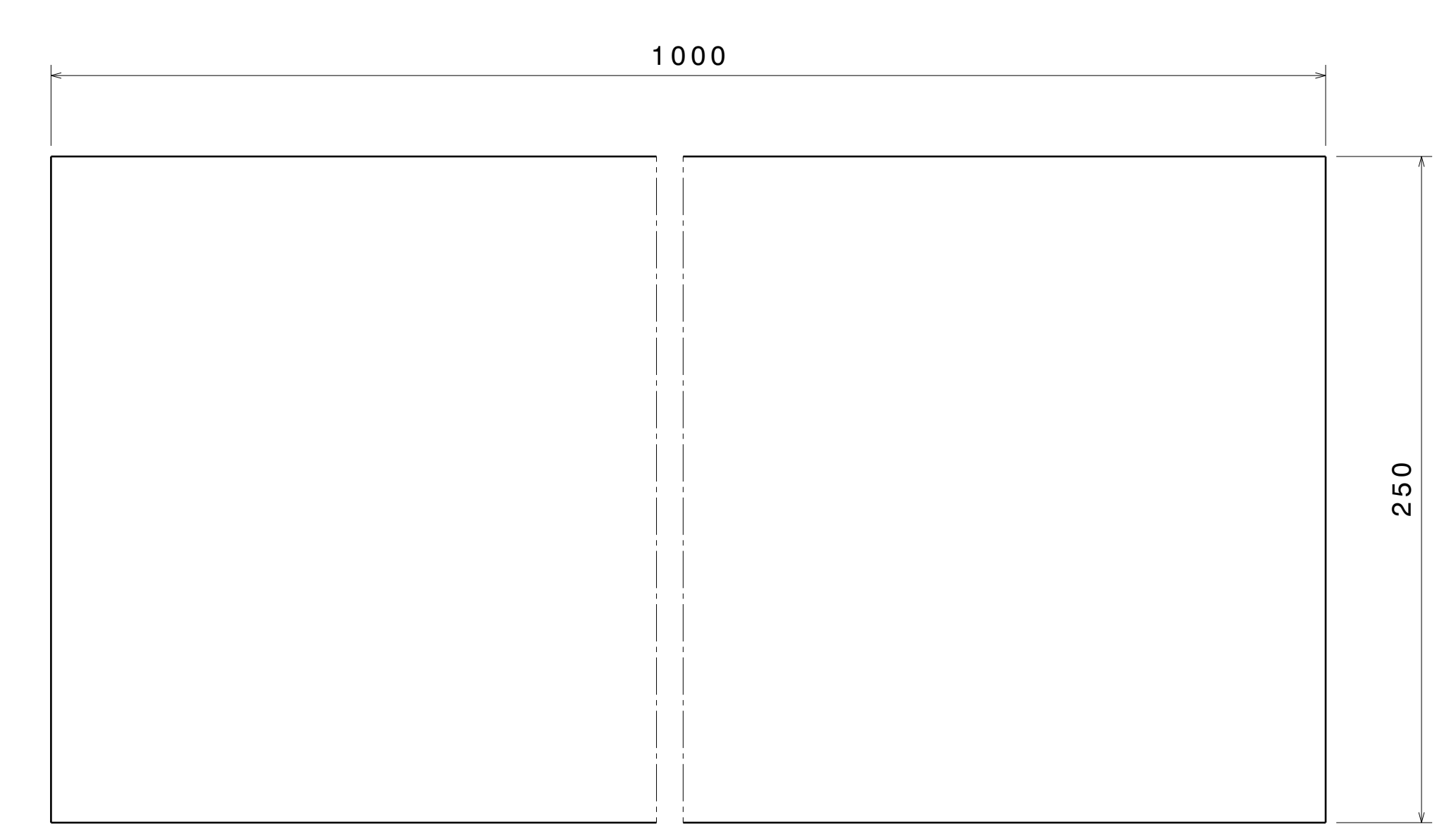

ITEM 4

Right view[2]
Scale: 1:2

UNLESS OTHERWISE SPECIFIED DIMENSION ARE IN MM
VIEWS: THIRD ANGLE PROJECTION

| | | | |
|---|--------------------------------|-----------------------|--------------|
| This drawing is our property. It can't be reproduced or communicated without our written agreement. | | APL APOLLO TUBES LTD. | |
| DRAWN BY SB | | DATE 16FEB2021 | |
| CHECKED BY P2P Analysis & Solutions | | DATE 16FEB2021 | |
| DESIGNED BY P2P Analysis & Solutions | | DATE 16FEB2021 | |
| SIZE A0 | DRAWING NUMBER P2P_FEB21-13 | | REV 00 |
| SCALE NONE | WEIGHT (kg) | XXX | SHEET 3 OF 3 |