

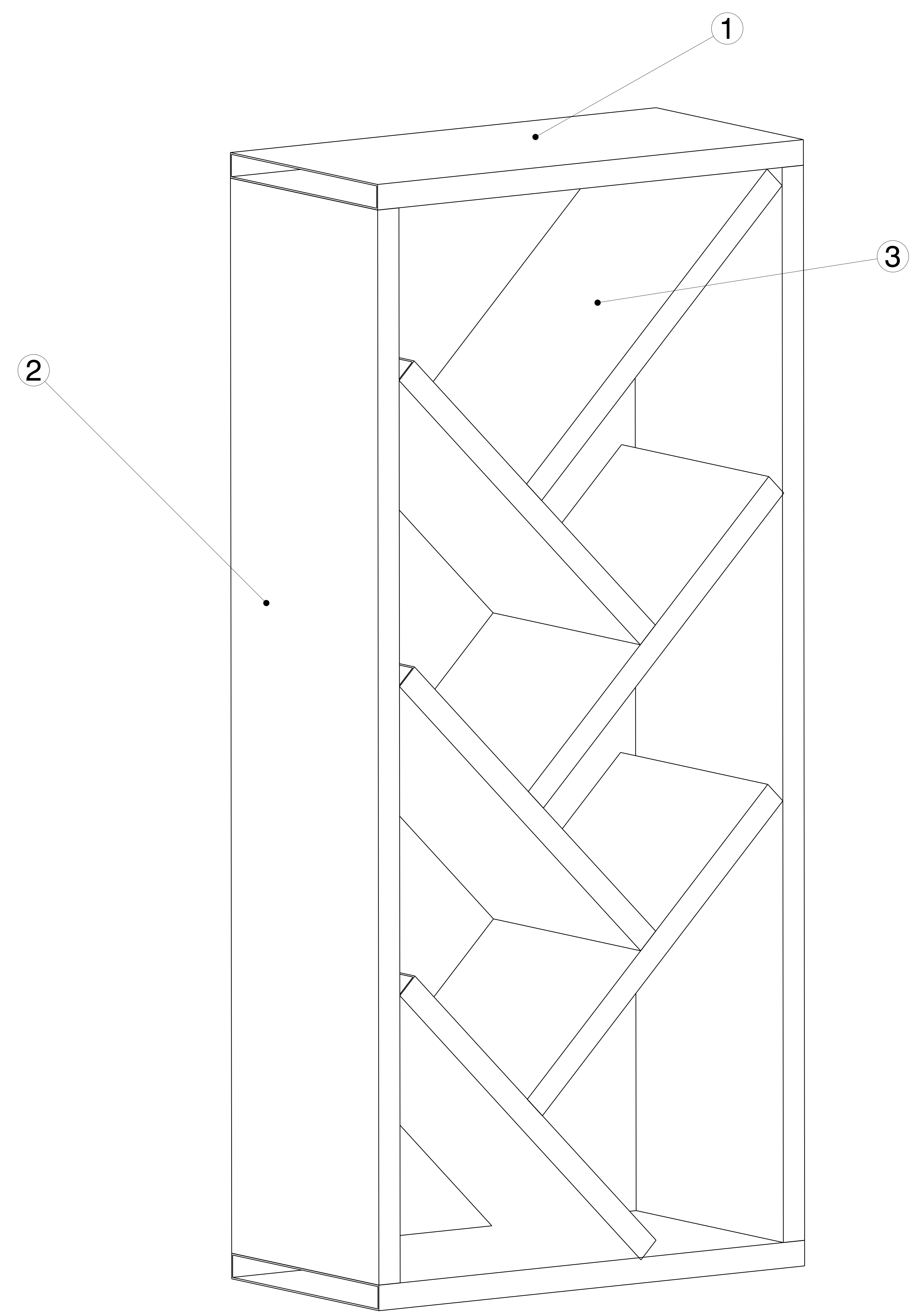

REV	DATE	DESCRIPTION
00	17 FEB 2021	INITIAL REVISION

- NOTES:
- (⊥) ALL VERTICAL SUPPORTS ARE PERPENDICULAR.
  - FLATNESS OF .5MM IS APPLIED BY DEFAULT.
  - ⊲ WELD BEAD OF 2MM RADIUS IS FOLLOWED.
  - ▽▽ SURFACE FINISH MEDIUM TO SMOOTH IS USED.
  - ALL TUBES ARE AS PER APL APOLLO STANDARD. CHANGES MAY EFFECT THE LOAD CAPACITY.
  - ALL HORIZONTAL AND VERTICAL TUBES ARE PERPENDICULAR TO EACH OTHER WITH ±1 DEG.
  - FINE WELDING IS REQUIRED AS PER MENTIONED DETAILS AND FINISHING.
  - HIGHER CURRENT WELDING MAY AFFECT THE BRITTLENESS OF MATERIAL WHICH LATER MAY RAISE TO WEAKENING OF STRUCTURE.
  - FABRICATORS ARE ALLOWED TO USE FITTINGS/FRAMES/SUPPORTS AS NEEDED AND THE SAME MUST BE COMMUNICATED BACK TO ENGINEERING TEAM.
  - BOP COMPONENT WEIGHTS ARE FOR REFERENCE ONLY AND SUBJECTED TO CHANGE PER PURCHASED COMPONENTS.



Isometric view  
Scale: 1:2

ITEM NO.	PART NUMBER	DESCRIPTION	QTY.	Wt (kg)/Each
3	PLANK 3	250 X 25 X 1.6 X 400	6	2.74
2	PLANK 2	250 X 25 X 1.6 X 1050	2	7.18
1	PLANK 1	250 X 25 X 1.6 X 500	2	3.42

This drawing is our property. It can't be reproduced or communicated without our written agreement.		APL APOLLO TUBES LTD. 	
DRAWN BY RR		DATE 17 FEB 2021	
CHECKED BY P2P Analysis & Solutions		DATE 17 FEB 2021	
DESIGNED BY P2P Analysis & Solutions		DATE 17 FEB 2021	
DRAWING TITLE BOOK STAND		SIZE A0	DRAWING NUMBER P2P_FEB21-07
SCALE As Indicated		WEIGHT (kg) 0kg	REV 00
		SHEET 1 OF 3	

UNLESS OTHERWISE SPECIFIED DIMENSION ARE IN MM  
VIEWS: THIRD ANGLE PROJECTION

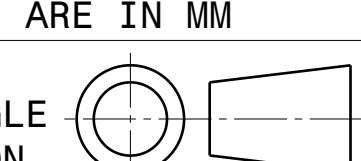

REV	DATE	DESCRIPTION
00	17 FEB 2021	INITIAL REVISION

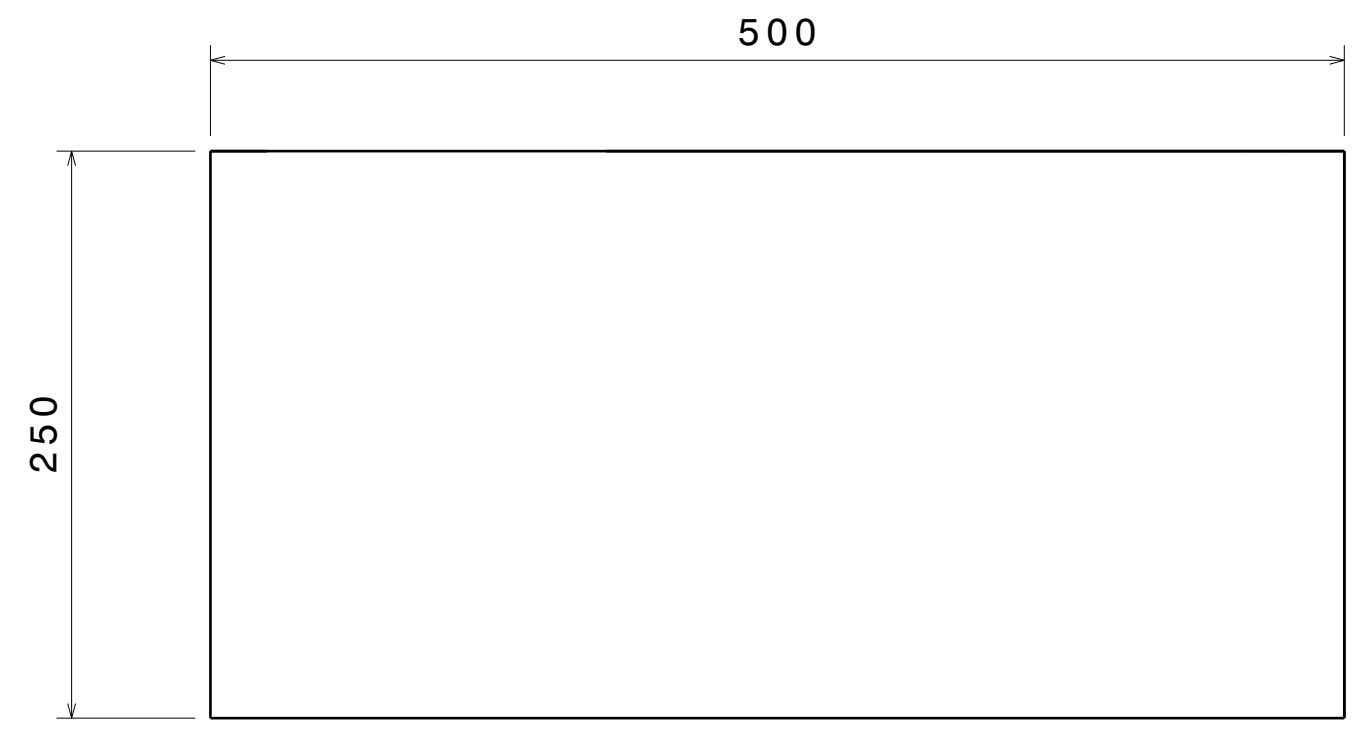

Top view  
Scale: 3:10

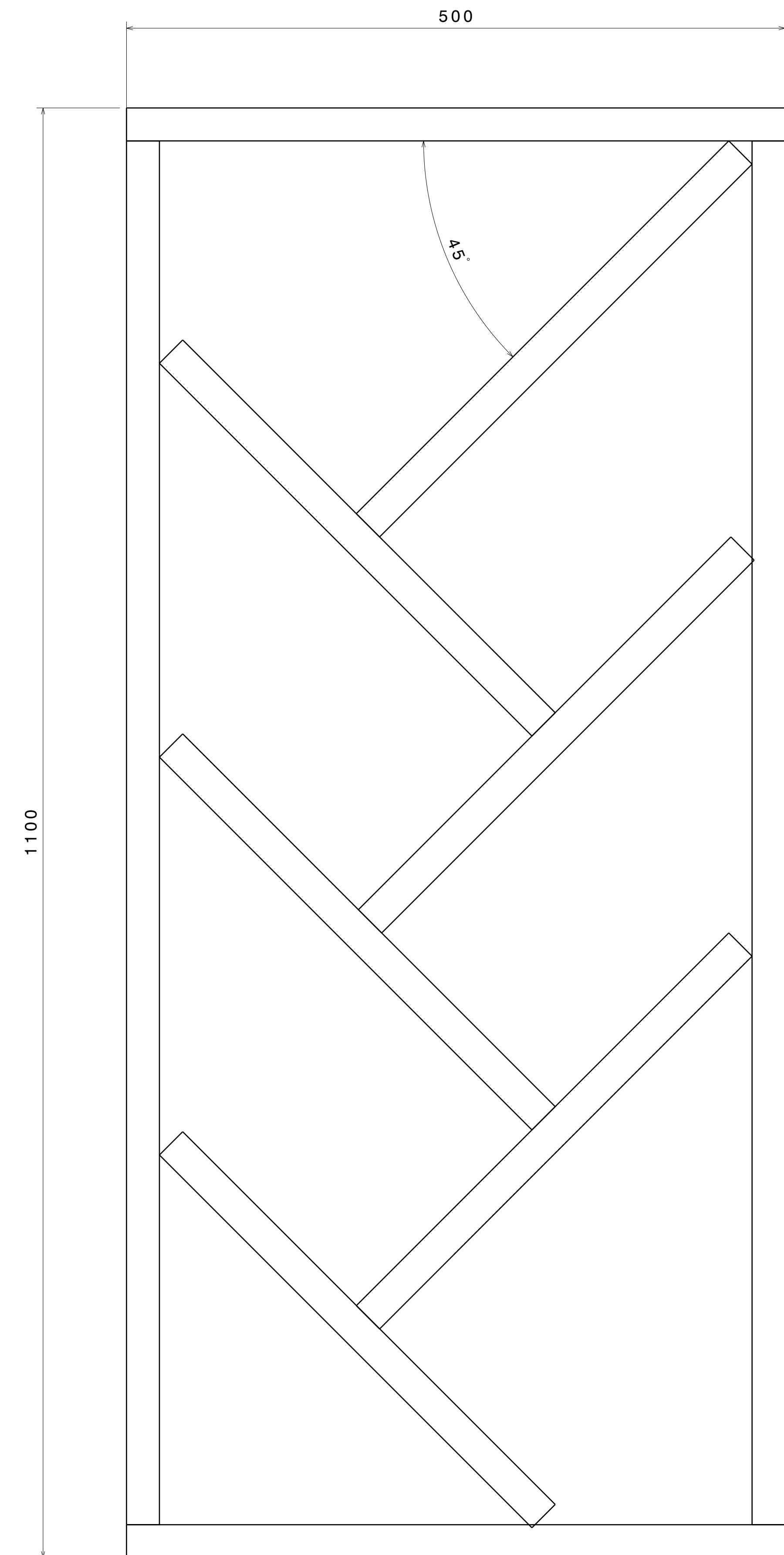

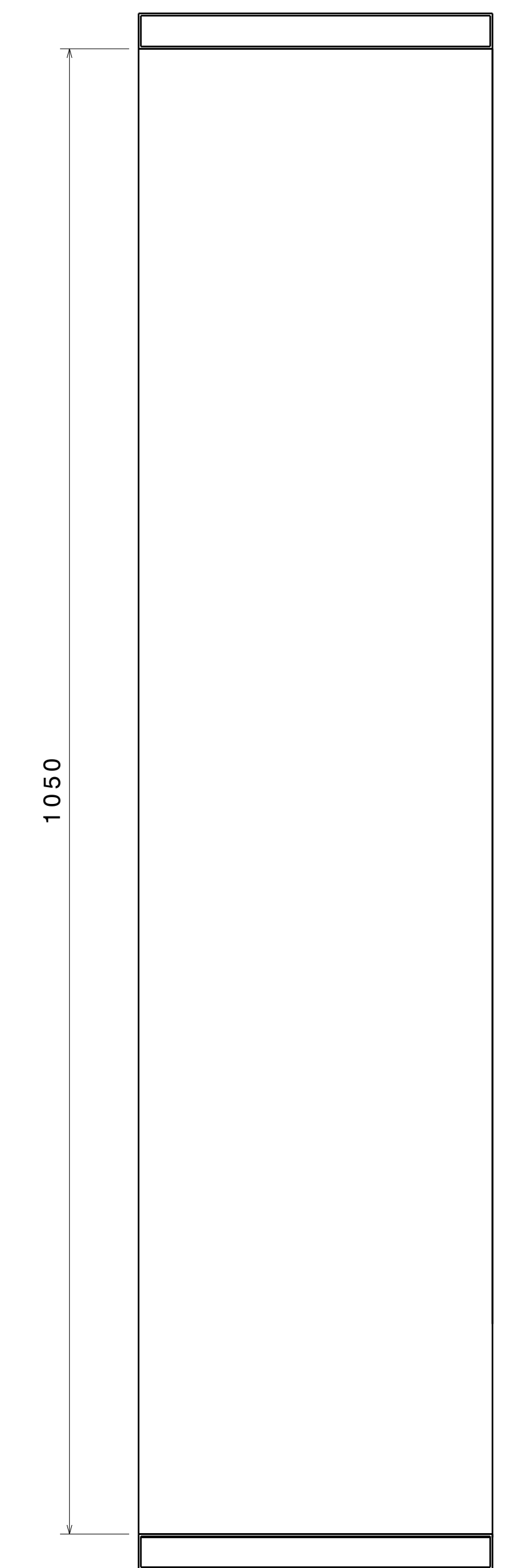

Front view  
Scale: 2:5

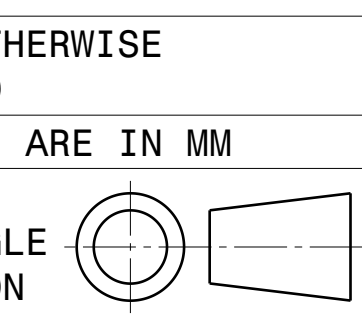

Right view  
Scale: 3:10

UNLESS OTHERWISE SPECIFIED DIMENSION ARE IN MM  
VIEWS: THIRD ANGLE PROJECTION



This drawing is our property. It can't be reproduced or communicated without our written agreement.		APL APOLLO TUBES LTD. 	
DRAWN BY: SB		DATE: 17 FEB 2021	
CHECKED BY: P2P Analysis & Solutions		DATE: 17 FEB 2021	
DESIGNED BY: P2P Analysis & Solutions		DATE: 17 FEB 2021	
DRAWING TITLE: BOOK STAND		SIZE: A0	DRAWING NUMBER: P2P_FEB21-07
SCALE: NONE		WEIGHT (kg): XXX	REV: 00
		SHEET 2 OF 3	

REV	DATE	DESCRIPTION
00	17 FEB 2021	INITIAL REVISION



ITEM 1

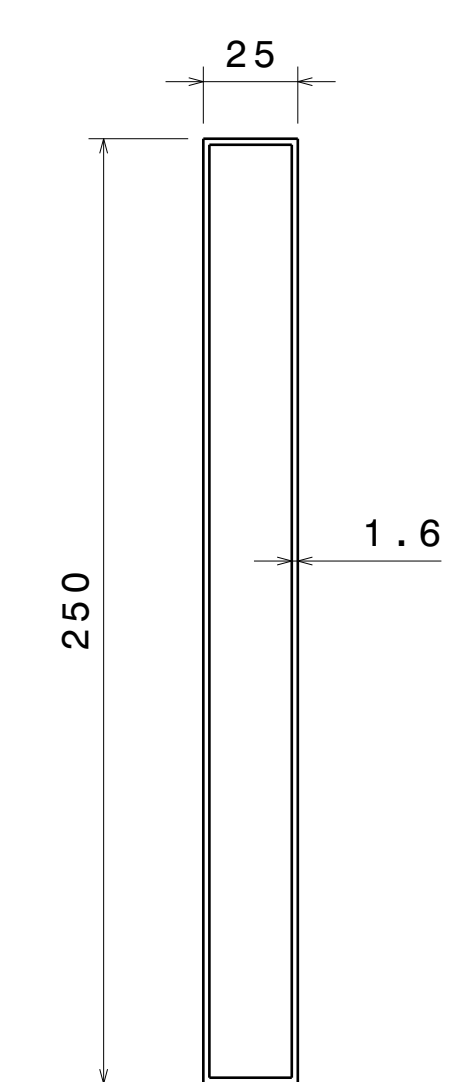

Right view  
Scale: 1:2

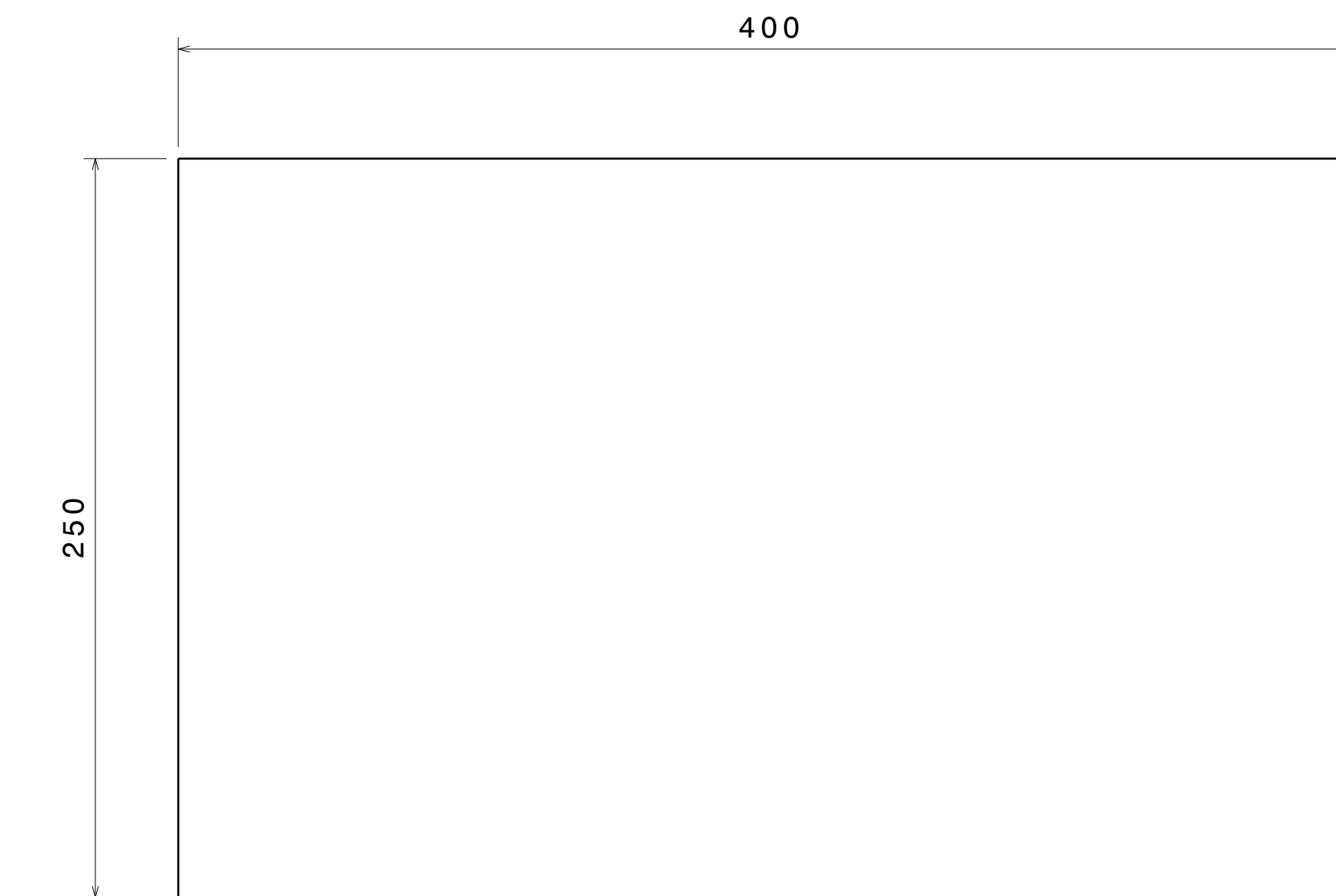

ITEM 3

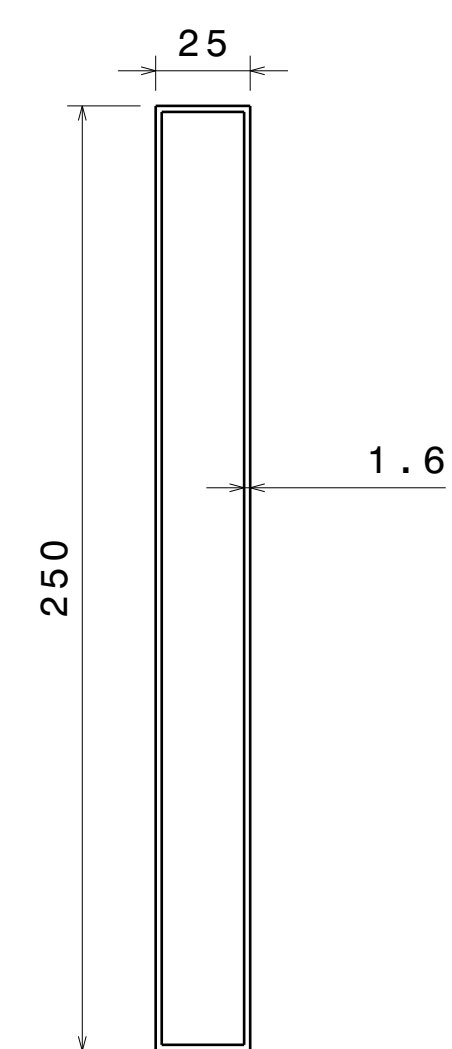

Right view  
Scale: 1:2

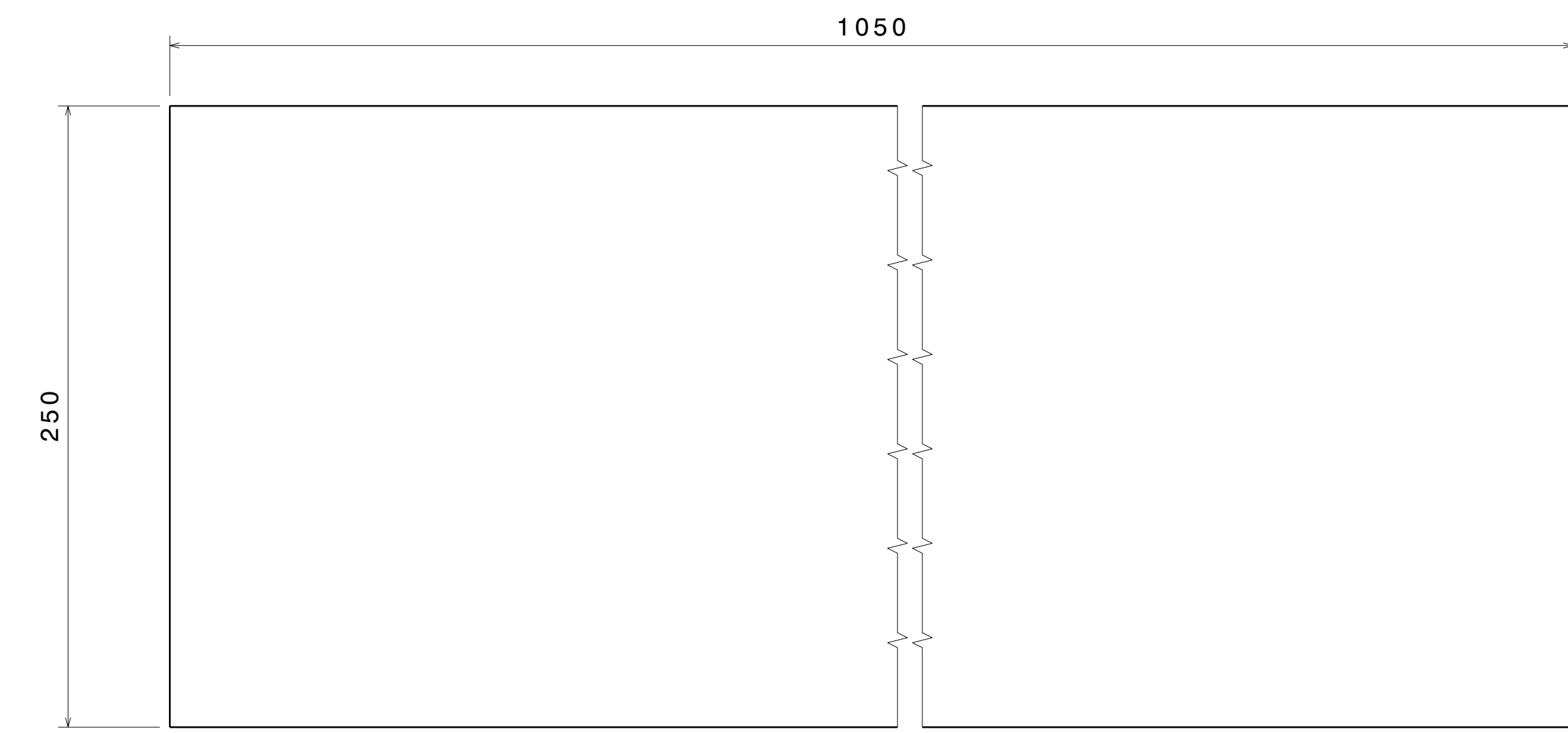

ITEM 2

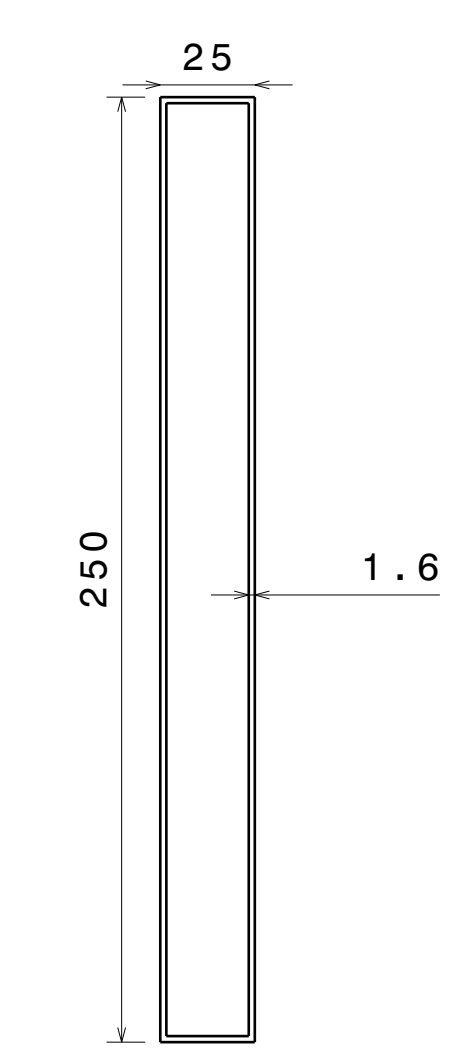

Right view  
Scale: 1:2

This drawing is our property.  
It can't be reproduced  
or communicated without  
our written agreement.

APL APOLLO TUBES LTD. 

UNLESS OTHERWISE  
SPECIFIED  
DIMENSION ARE IN MM  
VIEWS:  
THIRD ANGLE  
PROJECTION

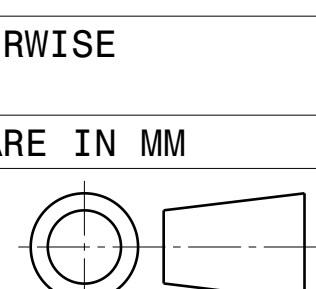

DRAWN BY	DATE	DRAWING TITLE	
SB	17 FEB 2021	BOOK STAND	
CHECKED BY	DATE	SIZE	DRAWING NUMBER
P2P Analysis & Solutions	17 FEB 2021	A0	P2P_FEB21-07
DESIGNED BY	DATE	SCALE	WEIGHT (kg)
P2P Analysis & Solutions	17 FEB 2021	NONE	XXX
		SHEET 3 OF 3	

REV  
00