

REV	DATE	DESCRIPTION
00	25JAN2021	INITIAL REVISION

- NOTES:
- (⊥) ALL VERTICAL SUPPORTS ARE PERPENDICULAR.
  - FLATNESS OF .5MM IS APPLIED BY DEFAULT.
  - ⊲ WELD BEAD OF 2MM RADIUS IS FOLLOWED.
  - ▽ SURFACE FINISH MEDIUM TO SMOOTH IS USED.
  - ALL TUBES ARE AS PER APL APOLLO STANDARD. CHANGES MAY EFFECT THE LOAD CAPACITY.
  - ALL HORIZONTAL AND VERTICAL TUBES ARE PERPENDICULAR TO EACH OTHER WITH ±1 DEG.
  - FINE WELDING IS REQUIRED AS PER MENTIONED DETAILS AND FINISHING.
  - HIGHER CURRENT WELDING MAY AFFECT THE BRITTLENESS OF MATERIAL WHICH LATER MAY RAISE TO WEAKENING OF STRUCTURE.
  - FABRICATORS ARE ALLOWED TO USE FITTINGS/FRAMES/SUPPORTS AS NEEDED AND THE SAME MUST BE COMMUNICATED BACK TO ENGINEERING TEAM.
  - BOP COMPONENT WEIGHTS ARE FOR REFERENCE ONLY AND SUBJECTED TO CHANGE PER PURCHASED COMPONENTS.

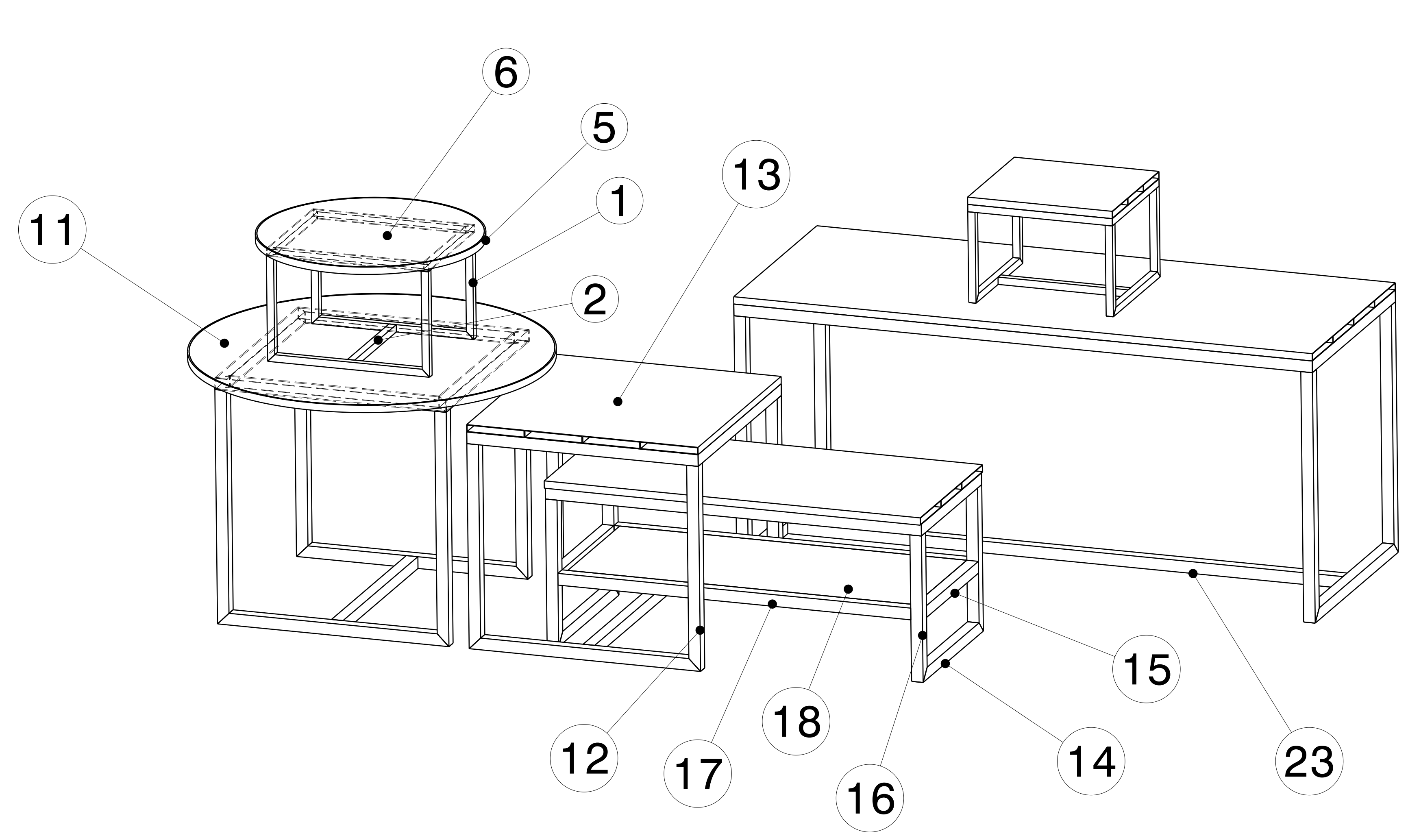

ISOMETRIC VIEW  
SCALE : 1:10

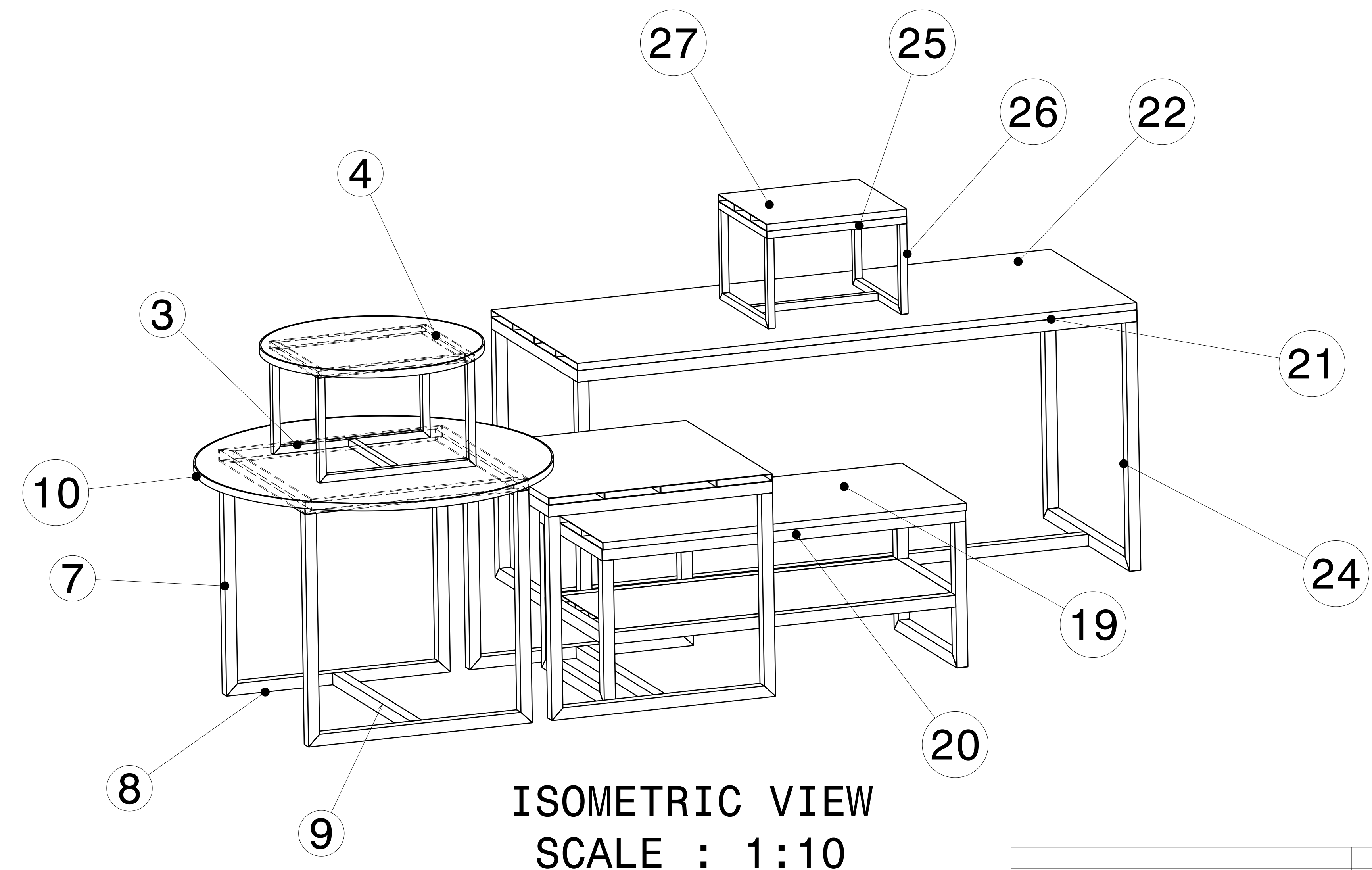

ISOMETRIC VIEW  
SCALE : 1:10

ITEM NO.	PART NUMBER	DESCRIPTION	QTY.	Wt (Kg)/Each
27	RHS PLANK 5	150 X 25 X 1.6 X 500	3	2.16
26	SHS FRAME 18	25 X 25 X 2 X 310	4	0.43
25	SHS FRAME 17	25 X 25 X 2 X 500	2	0.69
24	SHS FRAME 16	40 X 40 X 2.6 X 855	4	2.55
23	SHS FRAME 15	40 X 40 X 2.6 X 1920	1	5.87
22	RHS PLANK 4	200 X 25 X 1.6 X 2000	4	11.16
21	SHS FRAME 14	40 X 40 X 2.6 X 2000	2	6.12
20	SHS FRAME 13	40 X 40 X 2.6 X 1300	2	3.85
19	RHS PLANK 3	200 X 25 X 1.6 X 1300	3	7.25
18	RHS PLANK 2	125 X 25 X 1.6 X 1200	4	4.43
17	SHS FRAME 12	40 X 40 X 2.6 X 1220	2	3.73
16	SHS FRAME 11	40 X 40 X 2.6 X 500	4	1.15
15	SHS FRAME 10	40 X 40 X 2.6 X 500	2	1.53
14	SHS FRAME 9	40 X 40 X 2.6 X 580	4	1.65
13	RHS PLANK 1	200 X 25 X 1.6 X 800	4	4.46
12	SHS FRAME 8	40 X 40 X 2.6 X 700	4	1.63
11	BOP CIRCULAR PLATE	DIA 1190 X 10 THK	1	87.42
10	BOP CIRCULAR THIN RING	DIA 1200 X 5 THK	1	3.69
9	SHS FRAME 7	40 X 40 X 2.6 X 720	1	2.2
8	SHS FRAME 6	40 X 40 X 2.6 X 800	16	2.32
7	SHS FRAME 5	40 X 40 X 2.6 X 800	4	2.39
6	BOP CIRCULAR PLATE	DIA 740 X 10 THK	1	33.8
5	BOP CIRCULAR THIN RING	DIA 750 X 5 THK	1	2.3
4	SHS FRAME 4	25 X 25 X 2 X 450	6	0.62
3	SHS FRAME 3	25 X 25 X 2 X 560	4	0.78
2	SHS FRAME 2	25 X 25 X 2 X 400	1	0.58
1	SHS FRAME 1	25 X 25 X 2 X 360	4	0.5

This drawing is our property. It can't be reproduced or communicated without our written agreement.

**APL APOLLO TUBES LTD.**

DRAWING TITLE: **JAN 21-11**

DRAWN BY: **VM** DATE: **25JAN2021**

CHECKED BY: **P2P Analysis & Solutions** DATE: **25JAN2021**

DESIGNED BY: **P2P Analysis & Solutions** DATE: **25JAN2021**

UNLESS OTHERWISE SPECIFIED DIMENSION ARE IN MM VIEWS: THIRD ANGLE PROJECTION

SIZE	DRAWING NUMBER	REV
<b>A0</b>	<b>P2P JAN21-11</b>	<b>00</b>
SCALE	WEIGHT(kg)	SHEET 1 OF 3
<b>As Indicated</b>	<b>0kg</b>	

REV	DATE	DESCRIPTION
00	25JAN2021	INITIAL REVISION

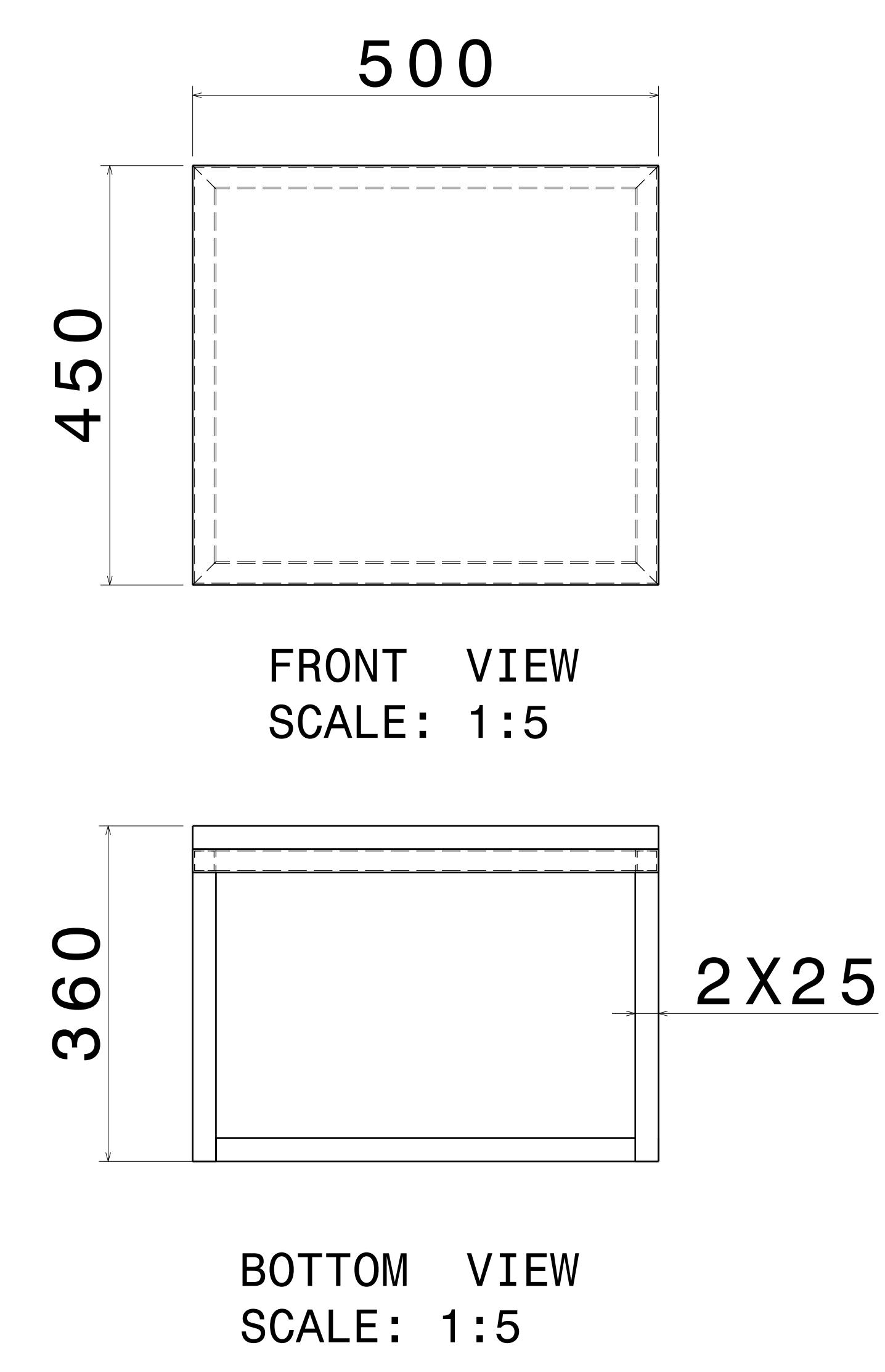
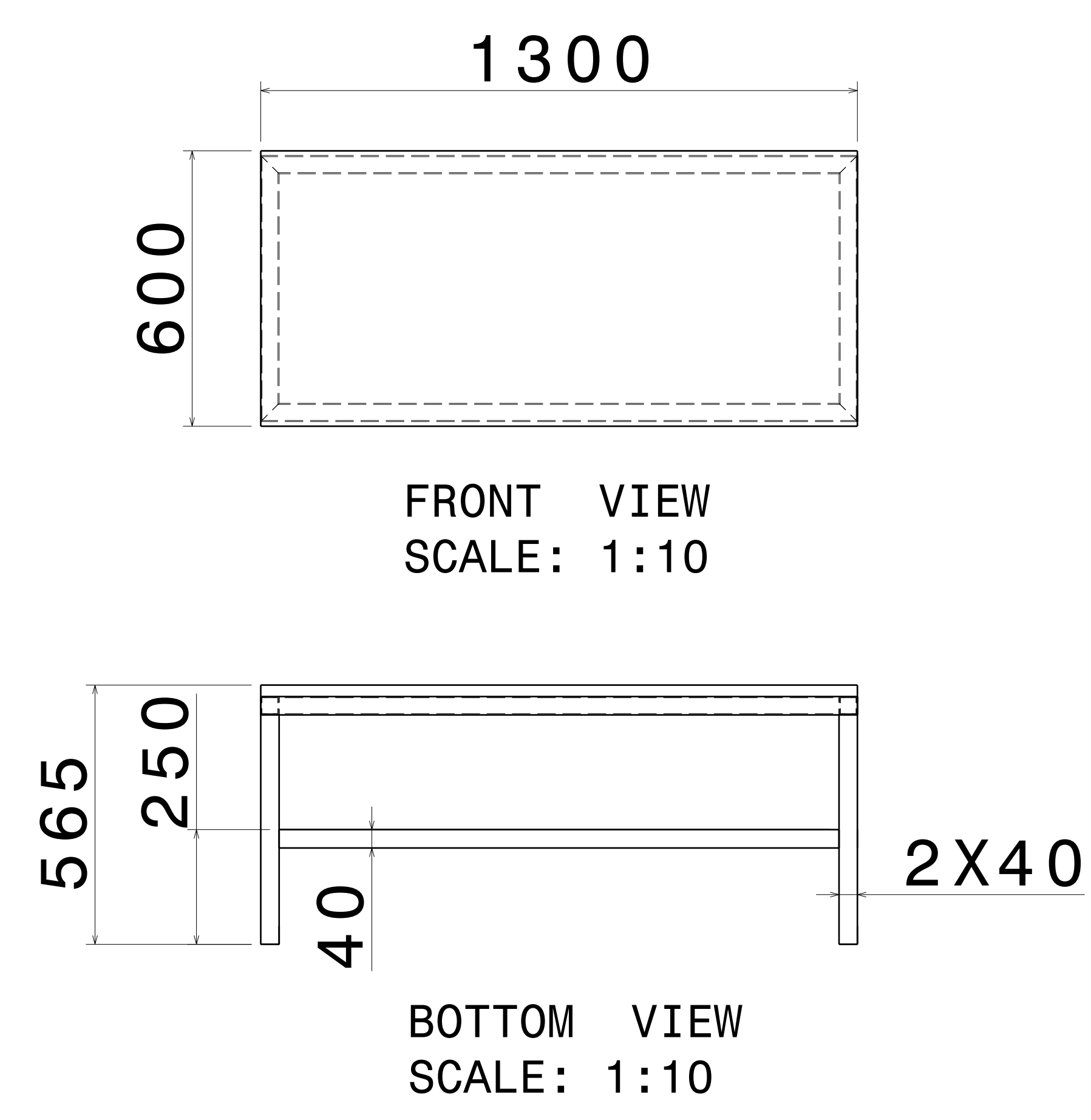
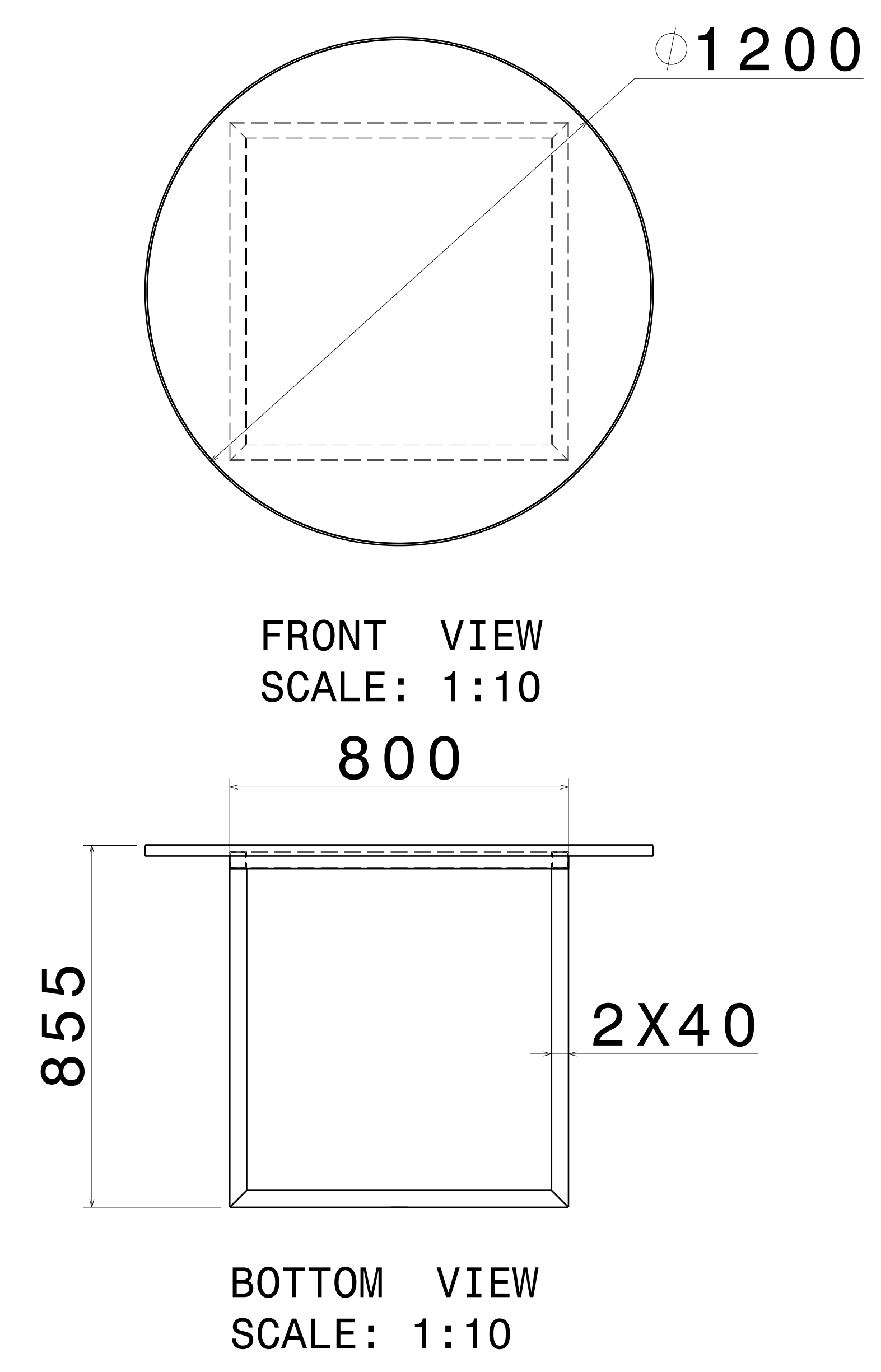
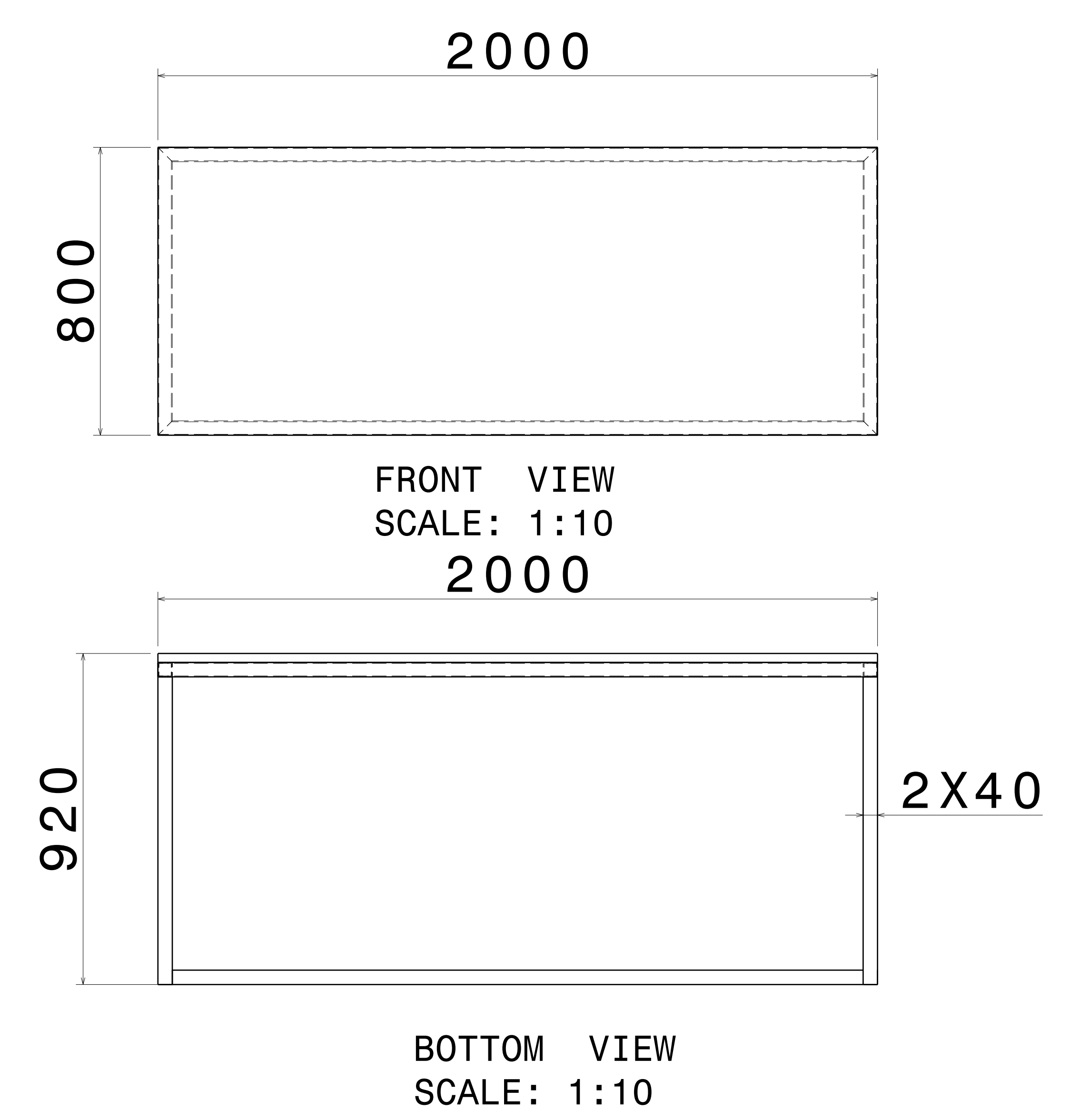
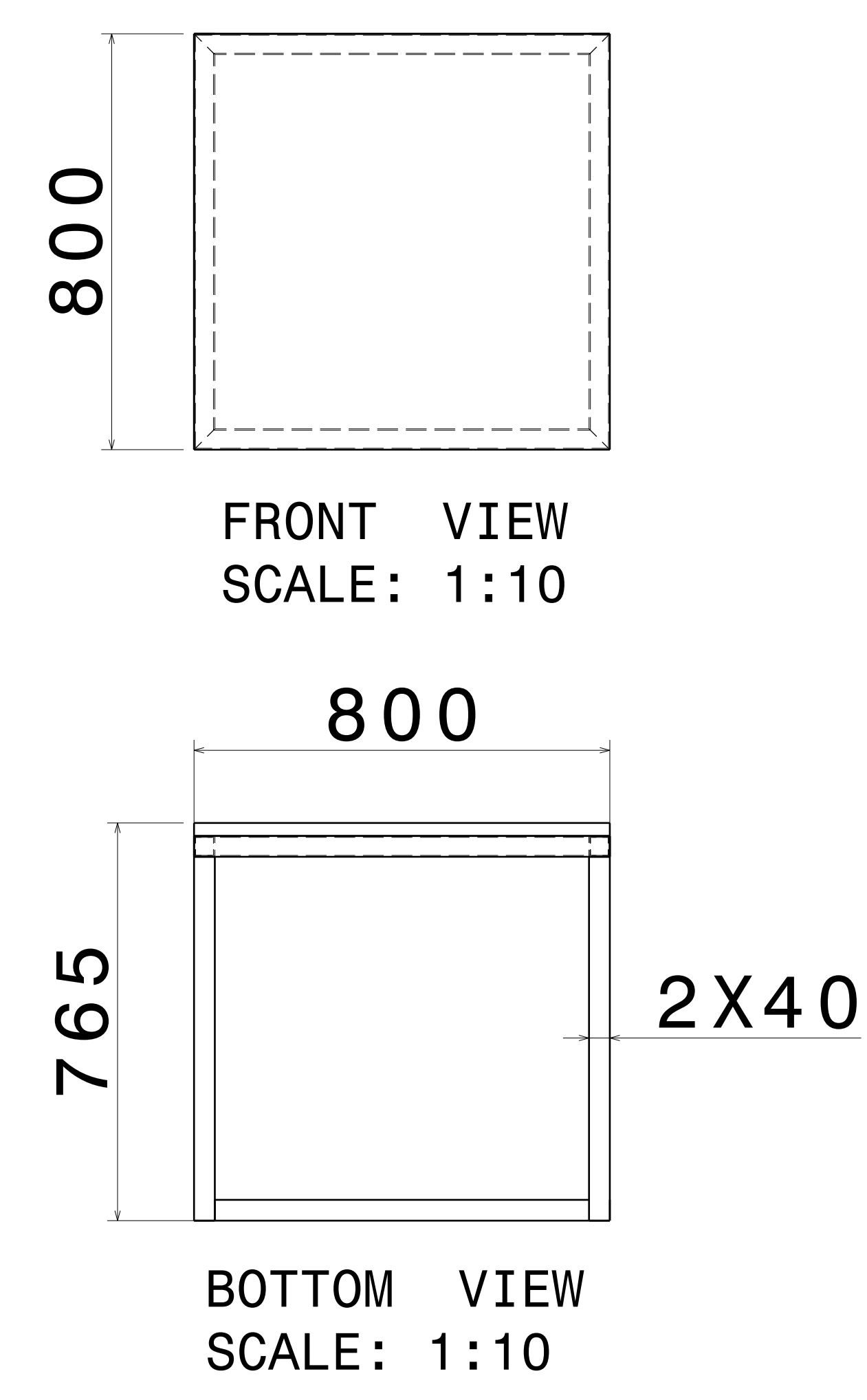
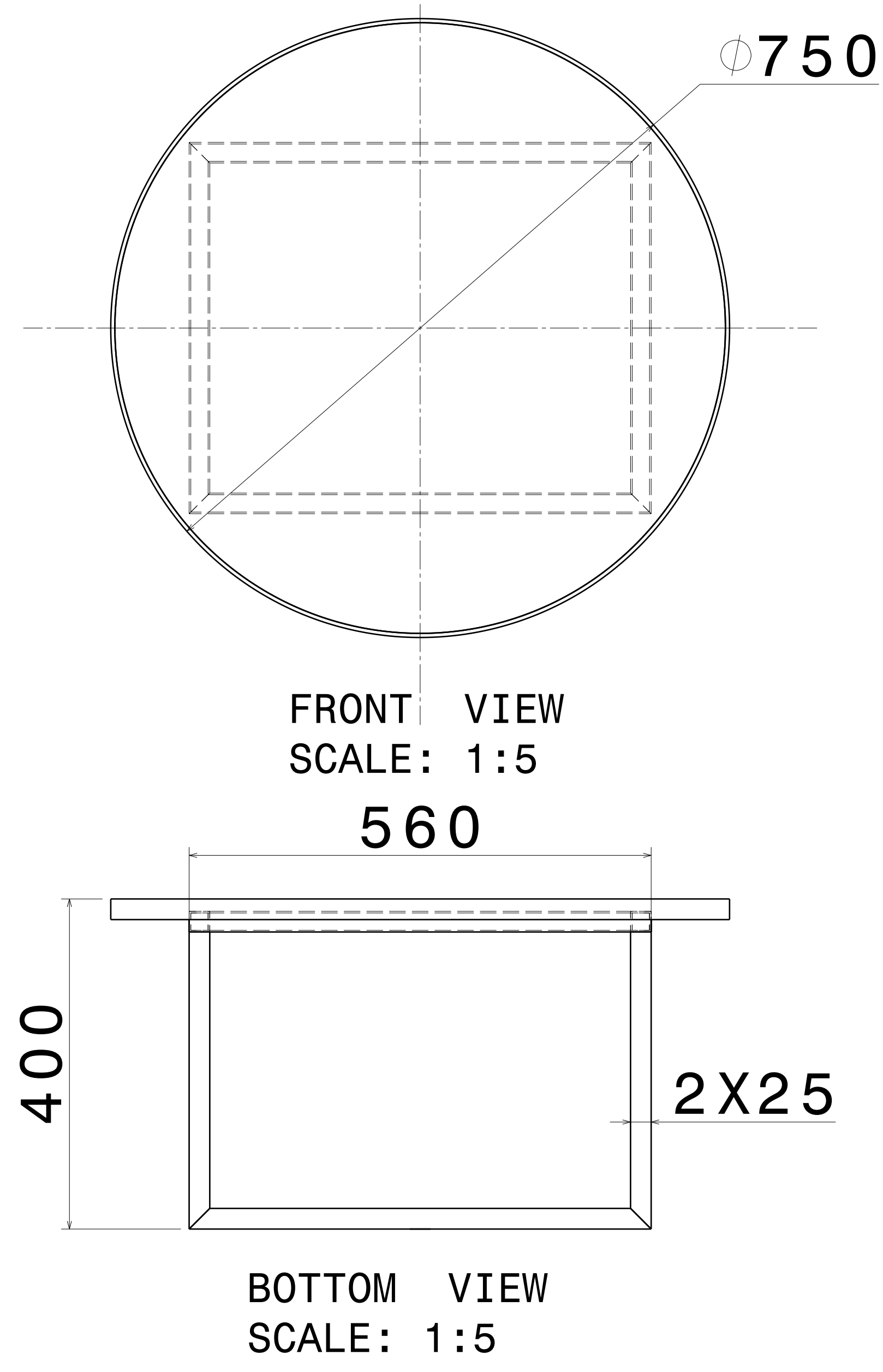

UNLESS OTHERWISE SPECIFIED DIMENSION ARE IN MM  
VIEWS: THIRD ANGLE PROJECTION

This drawing is our property. It can't be reproduced or communicated without our written agreement.		APL APOLLO TUBES LTD.	
DRAWN BY SB		DATE 25JAN2021	
CHECKED BY P2P Analysis & Solutions		DATE 25JAN2021	
DESIGNED BY P2P Analysis & Solutions		DATE 25JAN2021	
SIZE A0	DRAWING NUMBER P2P_JAN21-11		REV 00
SCALE NONE	WEIGHT (kg)	XXX	SHEET 2 OF 3



REV	DATE	DESCRIPTION
00	25JAN2021	INITIAL REVISION

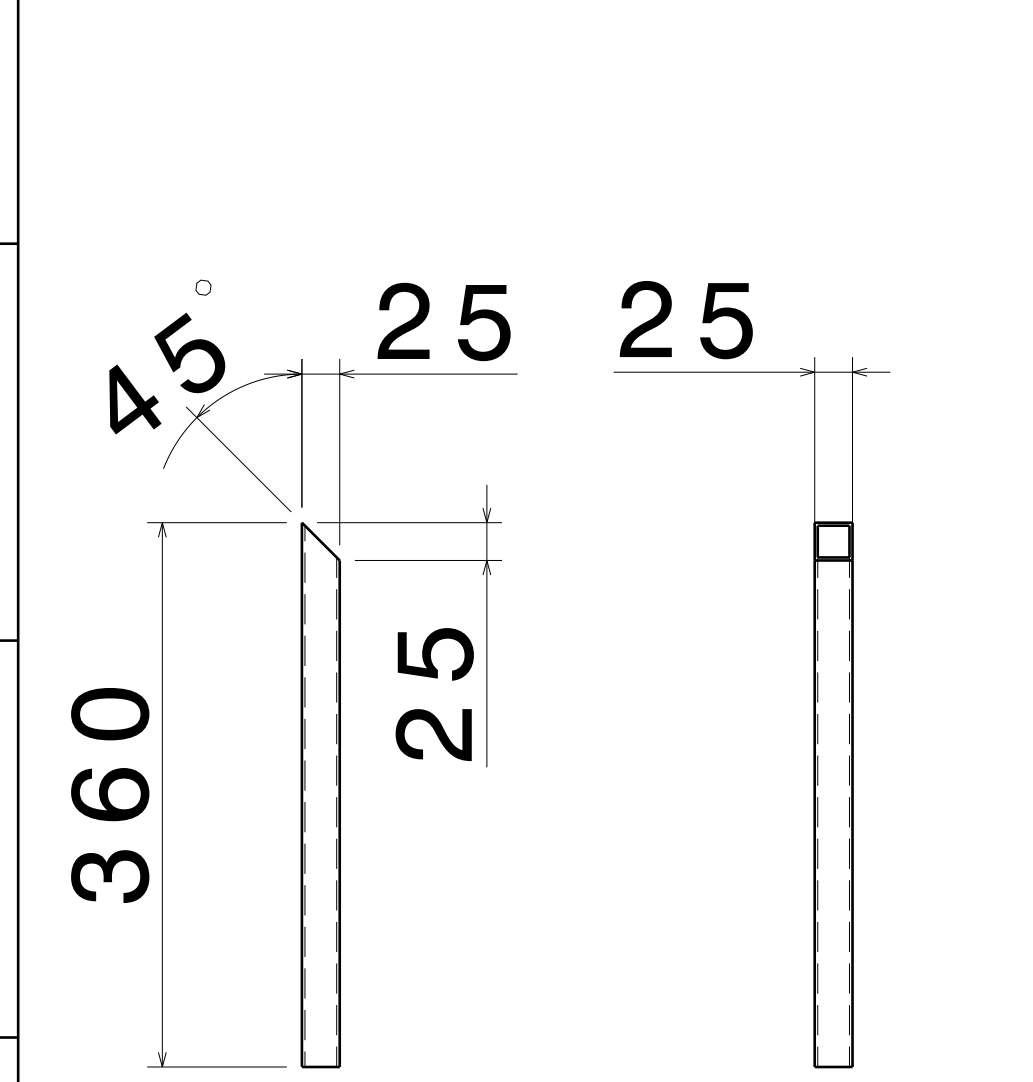

FRONT VIEW RIGHT VIEW  
SCALE: 1:5 SCALE: 1:5

ITEM 1, SHS FRAME 1  
THICKNESS - 2.0MM

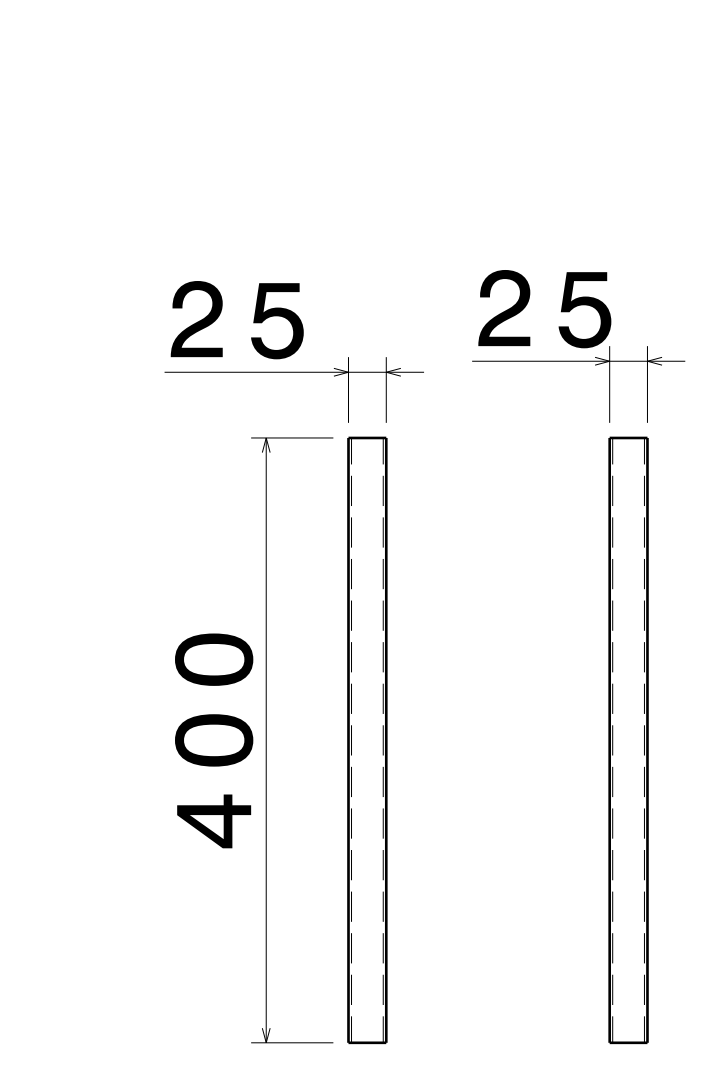

FRONT VIEW RIGHT VIEW  
SCALE: 1:5 SCALE: 1:5

ITEM 2, SHS FRAME 2  
THICKNESS - 2.0MM

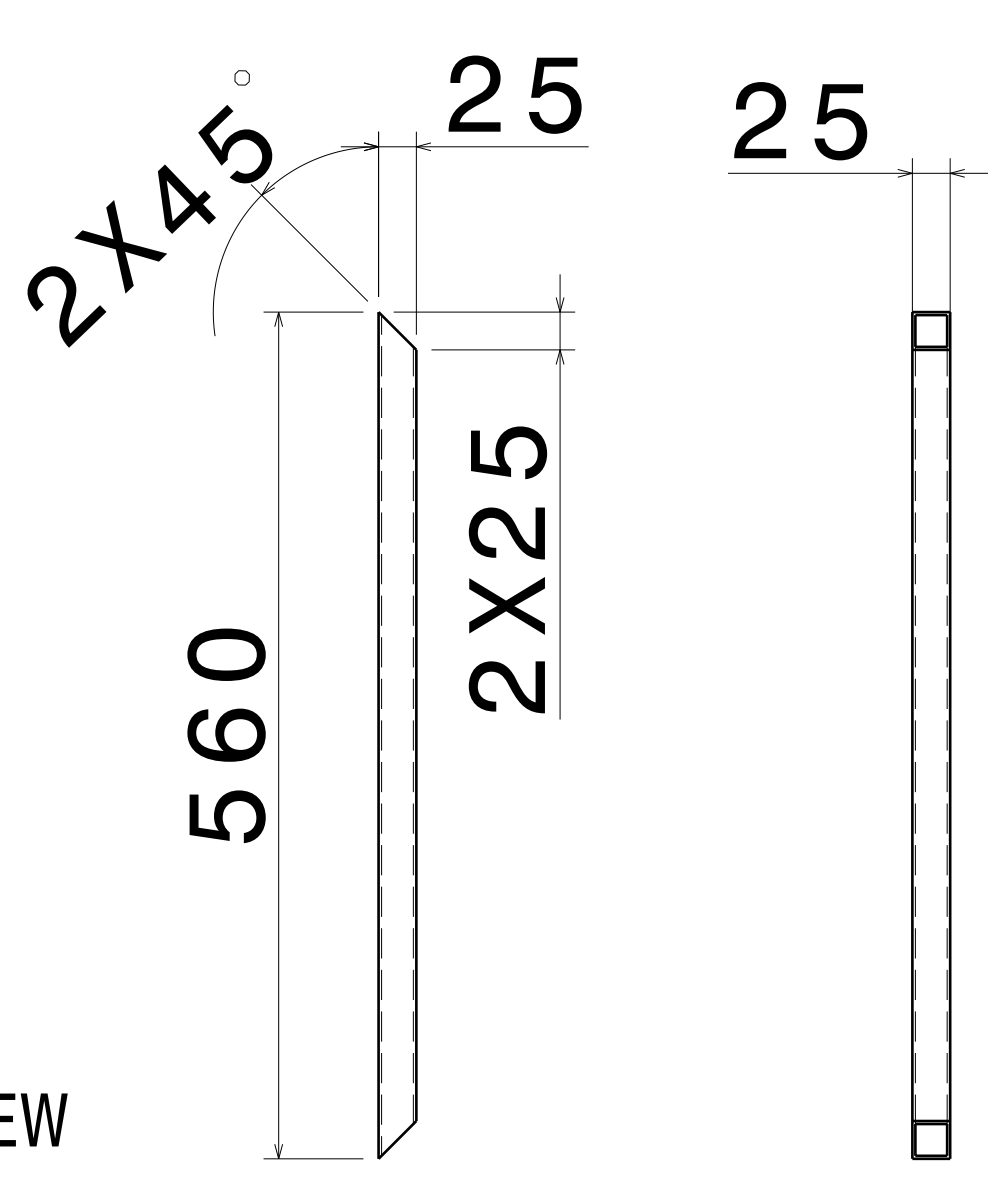

FRONT VIEW RIGHT VIEW  
SCALE: 1:5 SCALE: 1:5

ITEM 3, SHS FRAME 3  
THICKNESS - 2.0MM

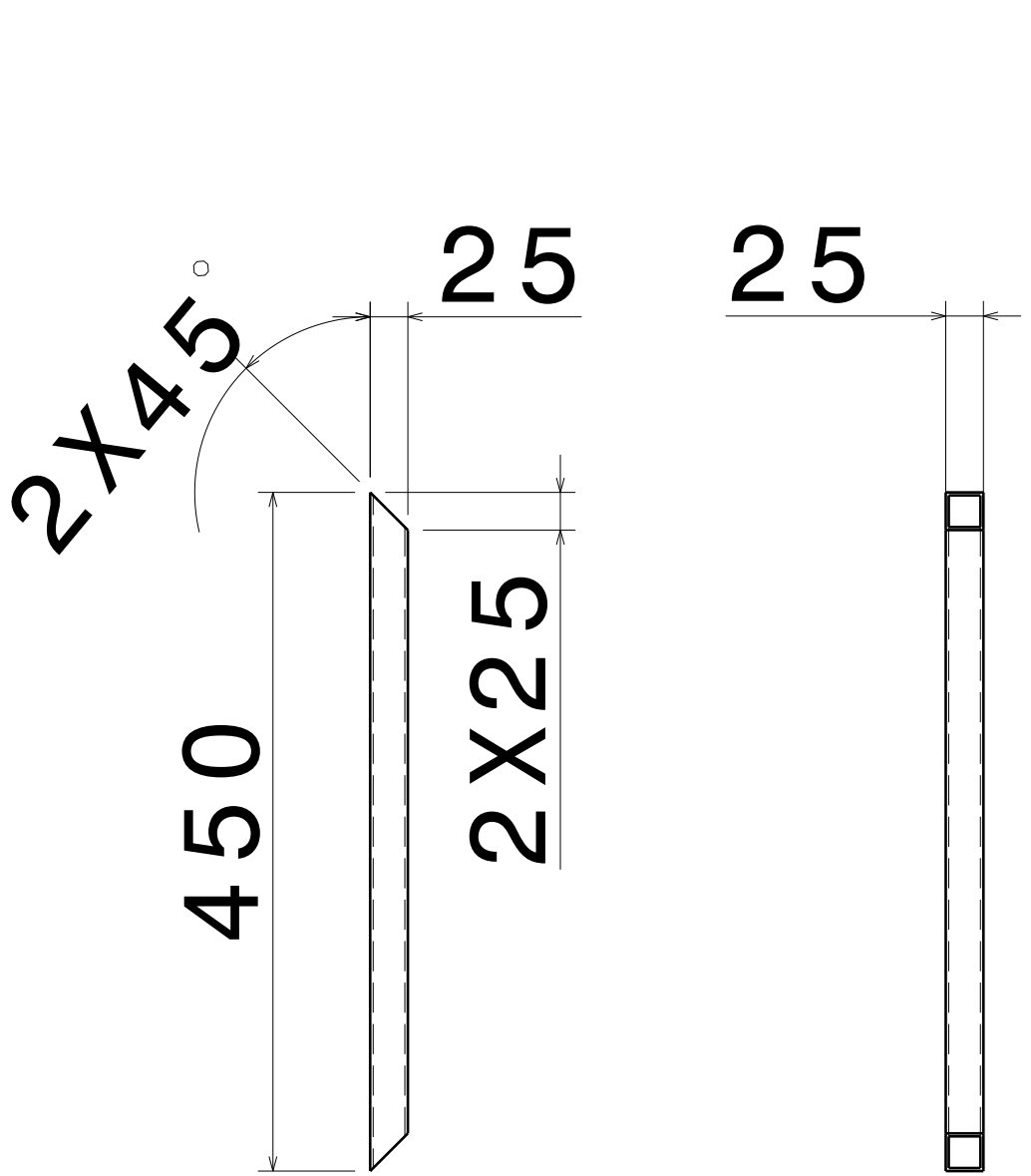

FRONT VIEW RIGHT VIEW  
SCALE: 1:5 SCALE: 1:5

ITEM 4, SHS FRAME 4  
THICKNESS - 2.0MM

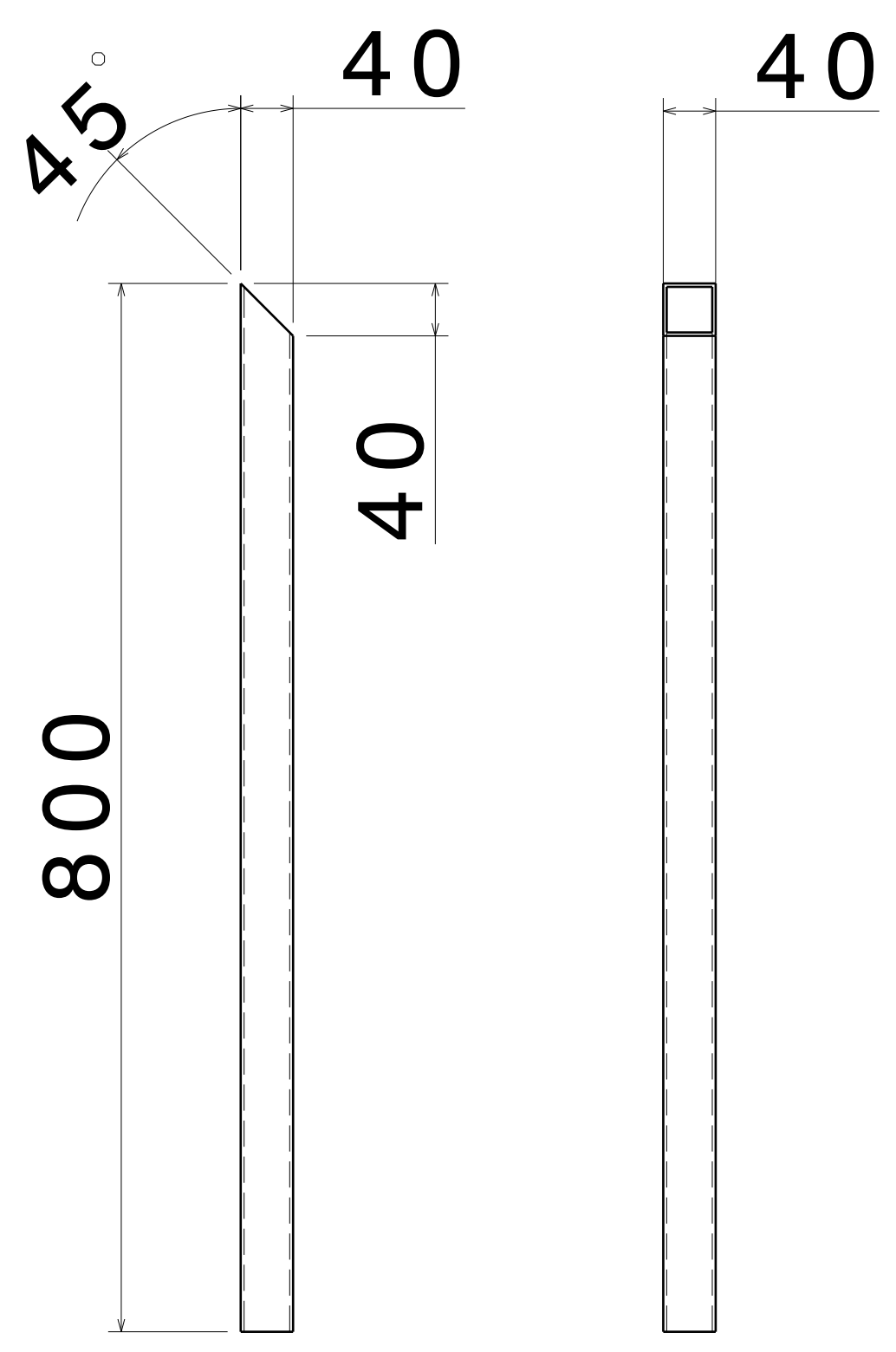

FRONT VIEW RIGHT VIEW  
SCALE: 1:5 SCALE: 1:5

ITEM 7, SHS FRAME 5  
THICKNESS - 2.6MM

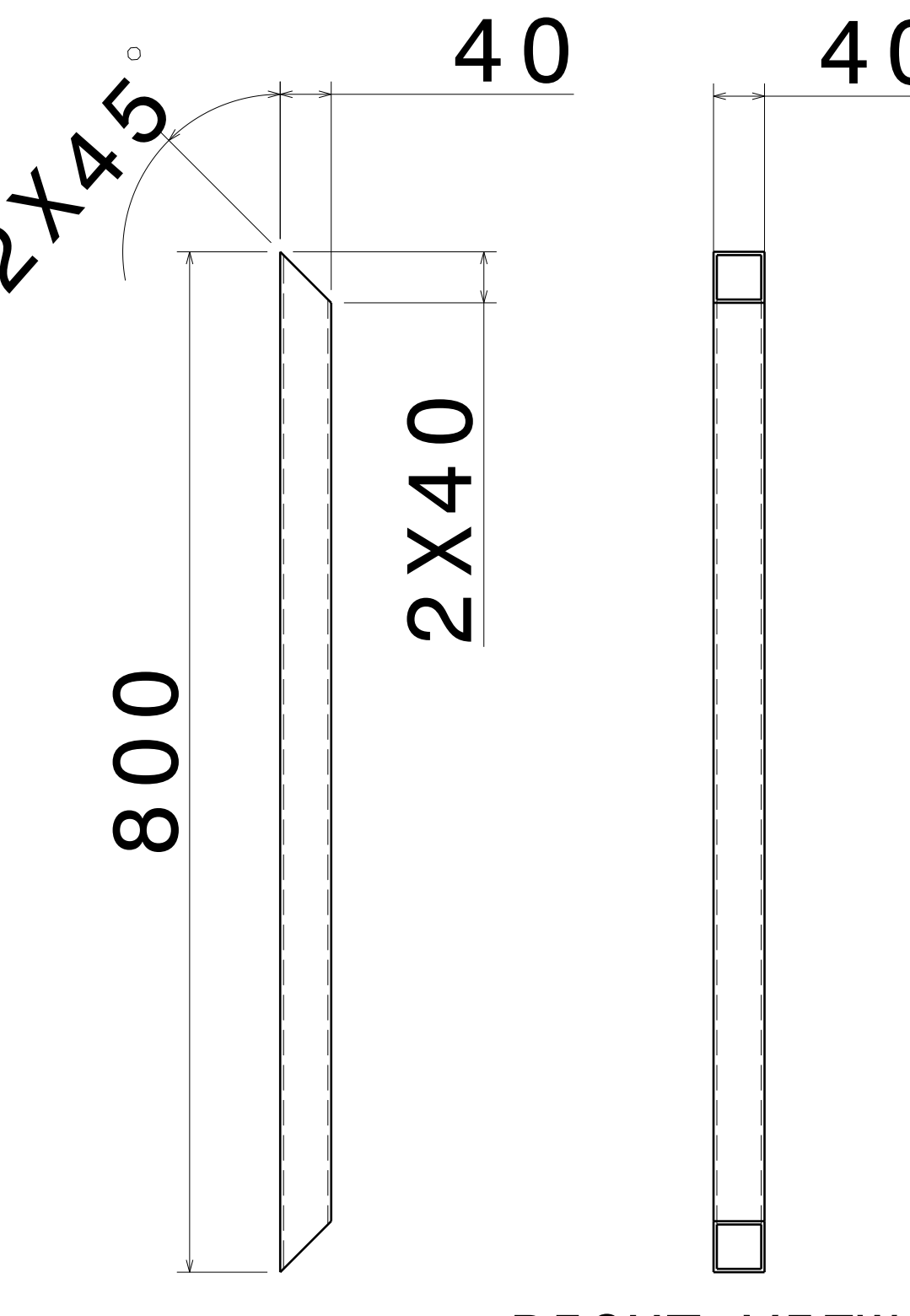

FRONT VIEW RIGHT VIEW  
SCALE: 1:5 SCALE: 1:5

ITEM 8, SHS FRAME 6  
THICKNESS - 2.6MM

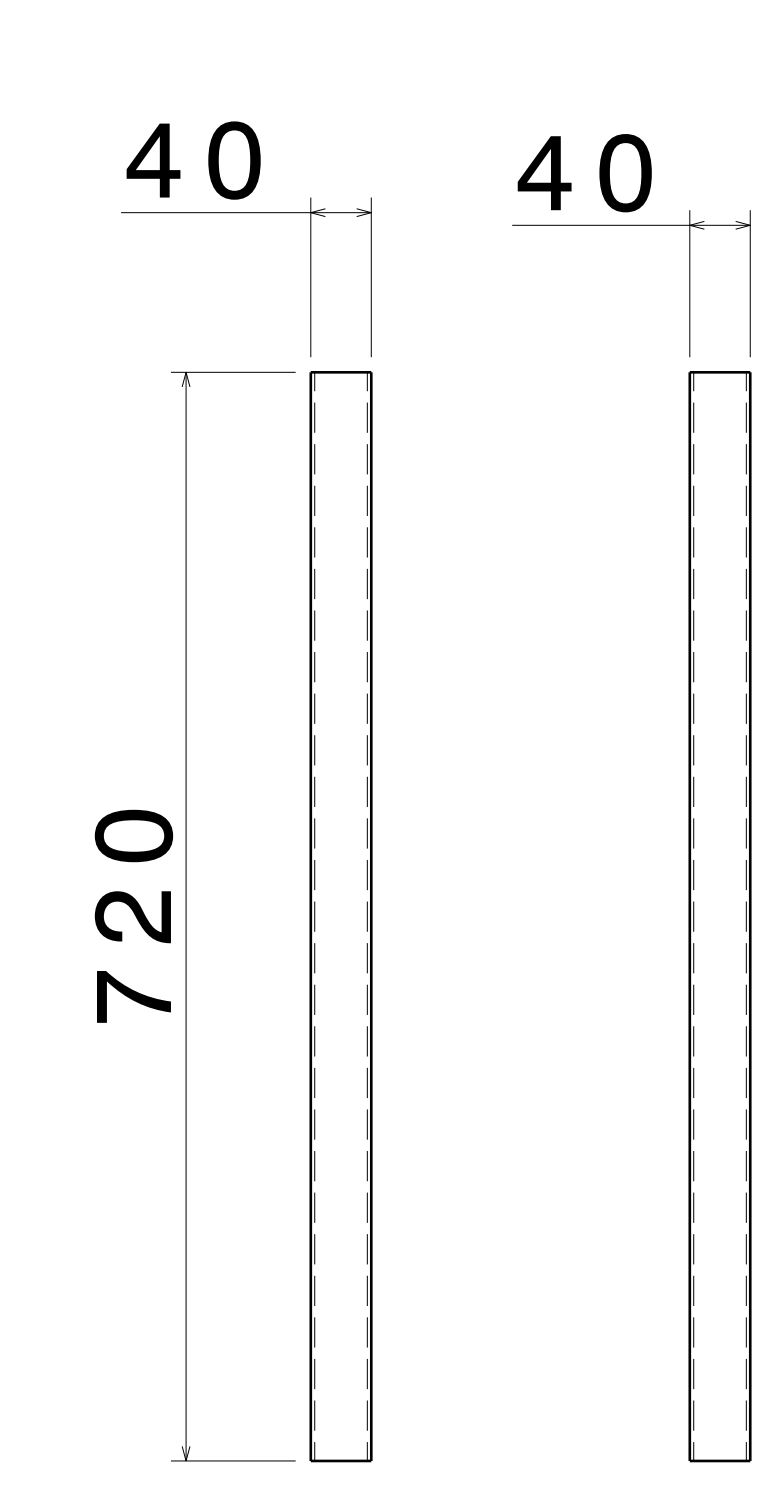

FRONT VIEW RIGHT VIEW  
SCALE: 1:5 SCALE: 1:5

ITEM 9, SHS FRAME 7  
THICKNESS - 2.6MM

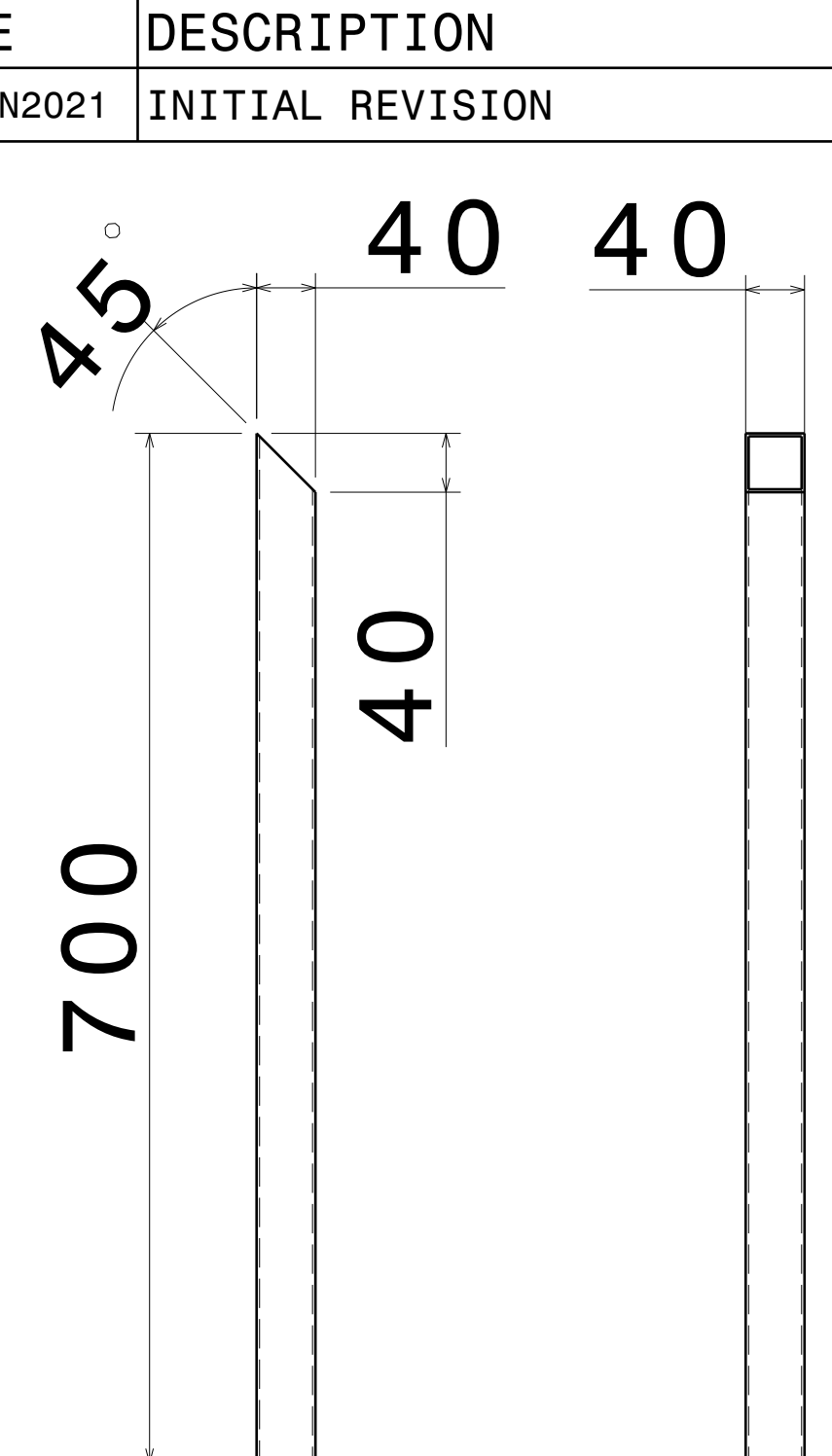

FRONT VIEW RIGHT VIEW  
SCALE: 1:5 SCALE: 1:5

ITEM 12, SHS FRAME 8  
THICKNESS - 2.6MM

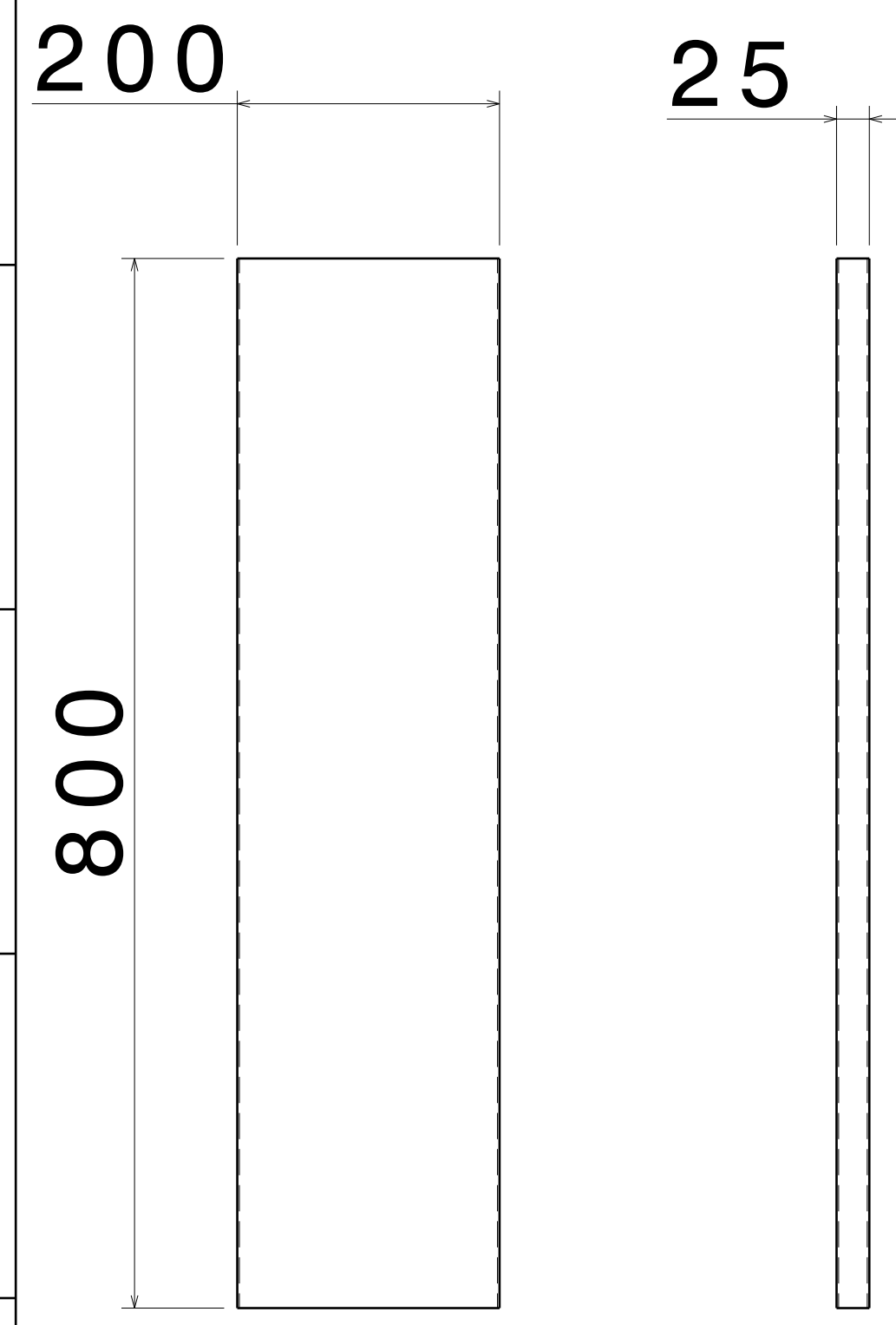

FRONT VIEW RIGHT VIEW  
SCALE: 1:5 SCALE: 1:5

ITEM 13, RHS PLANK 1  
THICKNESS - 1.6MM

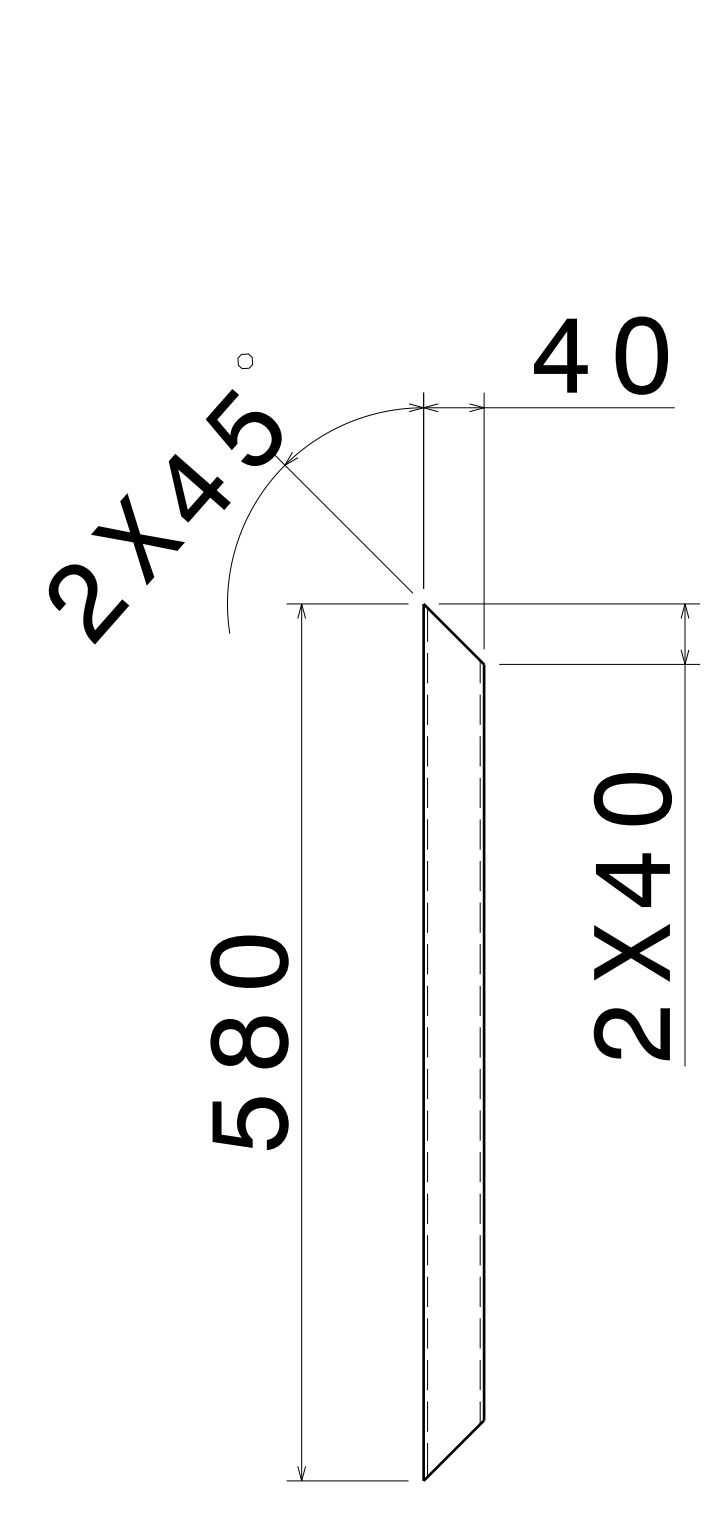

FRONT VIEW RIGHT VIEW  
SCALE: 1:5 SCALE: 1:5

ITEM 14, SHS FRAME 9  
THICKNESS - 2.6MM

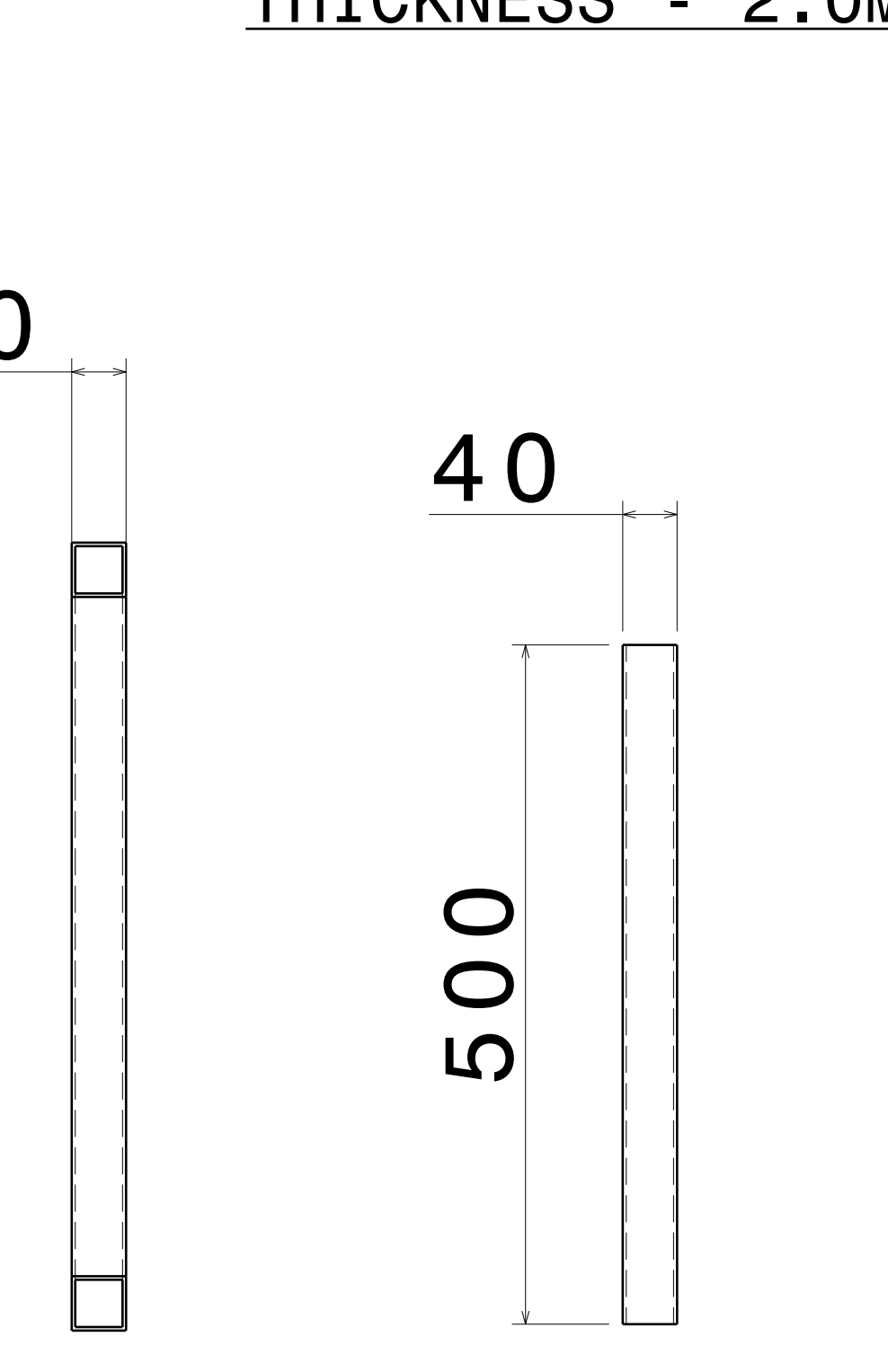

FRONT VIEW RIGHT VIEW  
SCALE: 1:5 SCALE: 1:5

ITEM 15, SHS FRAME 10  
THICKNESS - 2.6MM

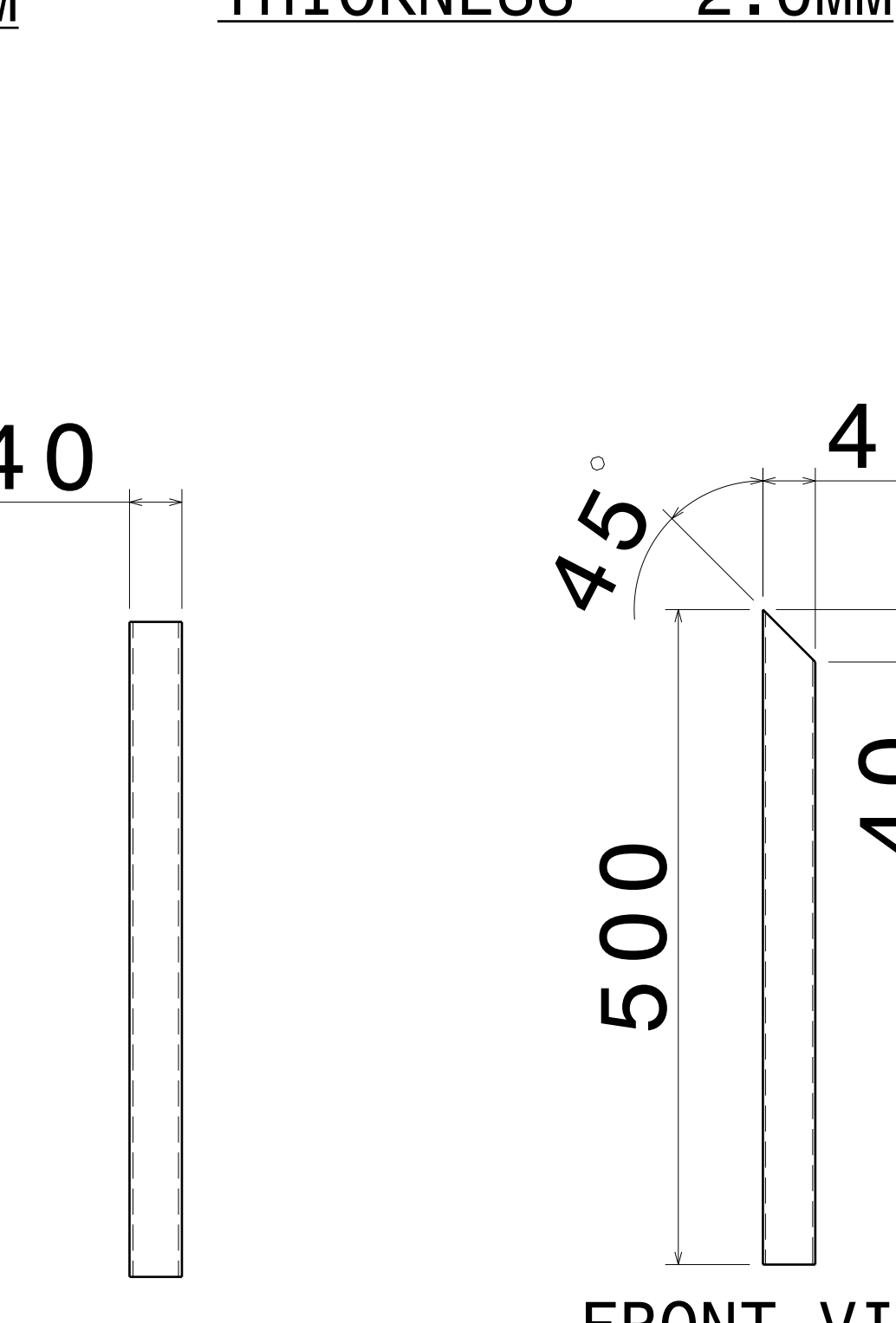

FRONT VIEW RIGHT VIEW  
SCALE: 1:5 SCALE: 1:5

ITEM 16, SHS FRAME 11  
THICKNESS - 2.6MM

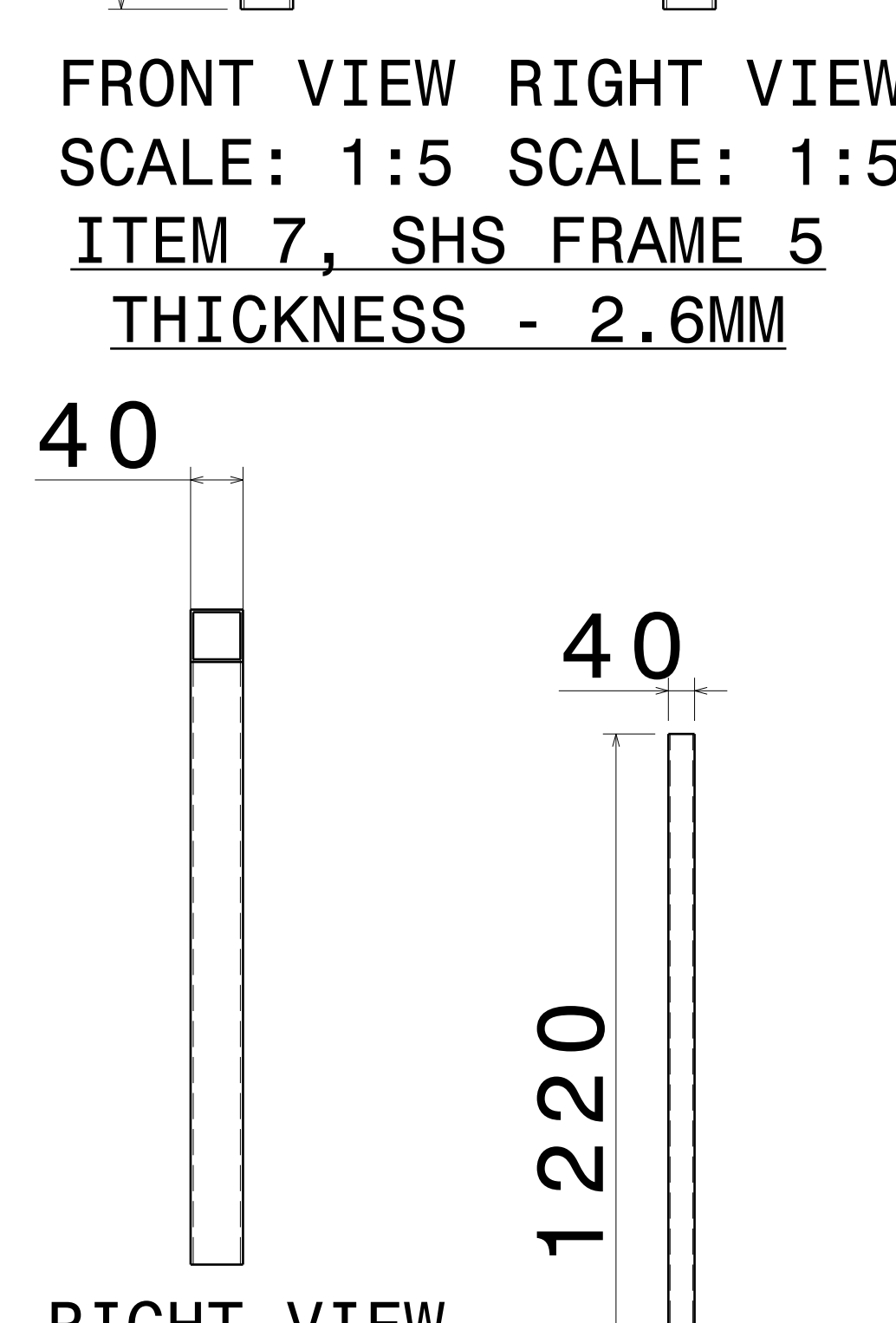

FRONT VIEW RIGHT VIEW  
SCALE: 1:10 SCALE: 1:10

ITEM 17, SHS FRAME 12  
THICKNESS - 2.6MM

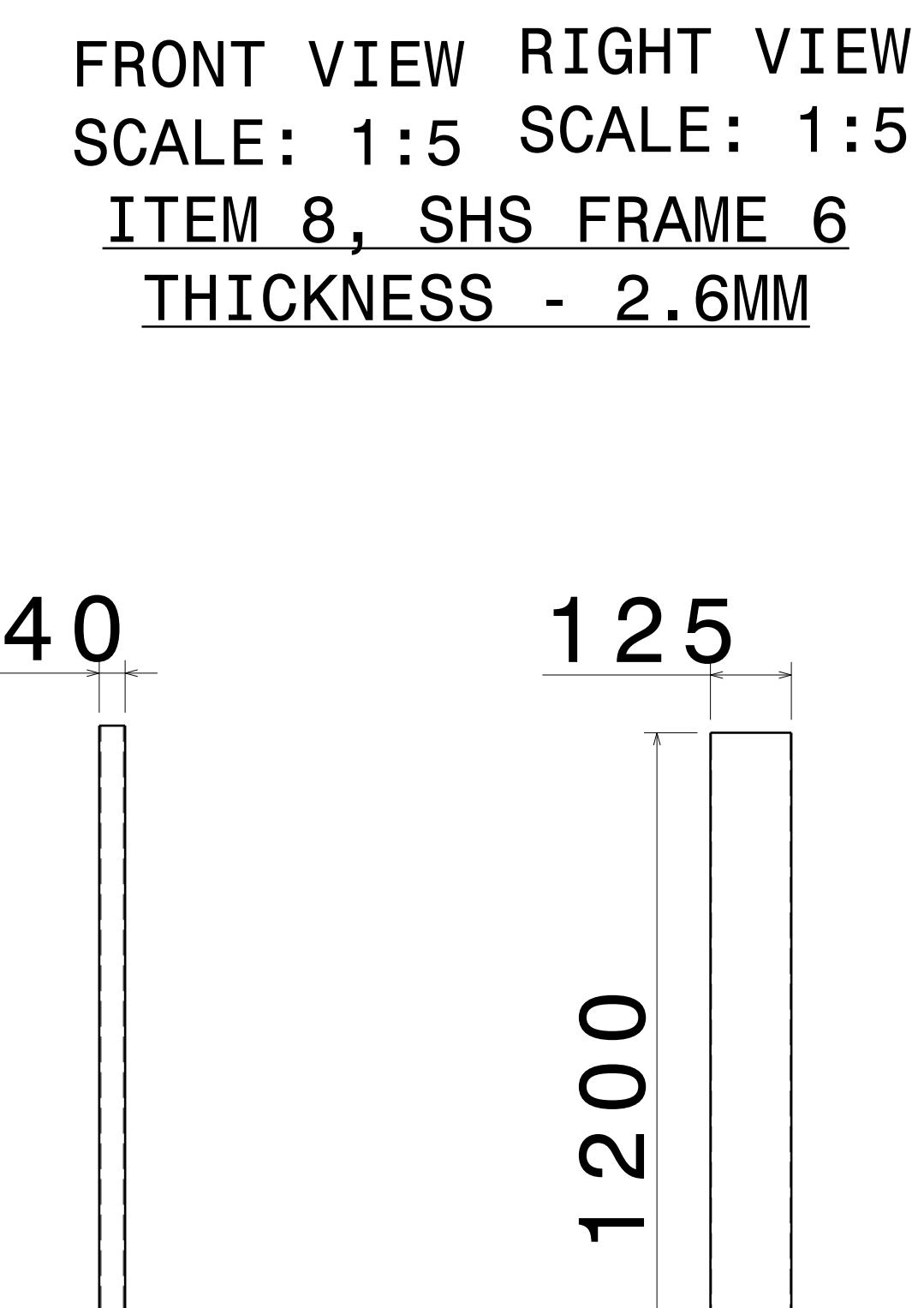

FRONT VIEW RIGHT VIEW  
SCALE: 1:5 SCALE: 1:5

ITEM 18, RHS PLANK 2  
THICKNESS - 1.6MM

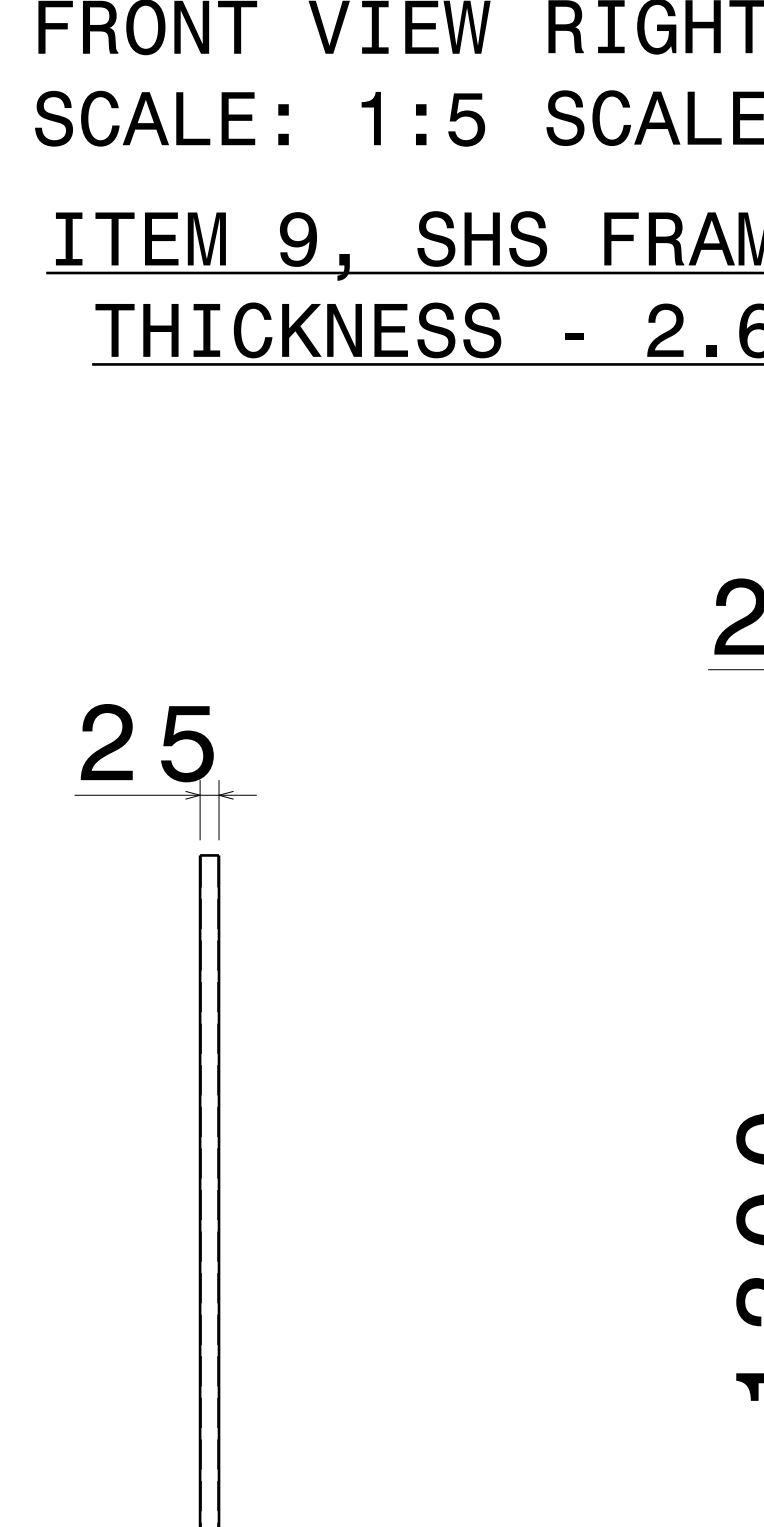

FRONT VIEW RIGHT VIEW  
SCALE: 1:10 SCALE: 1:10

ITEM 19, RHS PLANK 3  
THICKNESS - 1.6MM

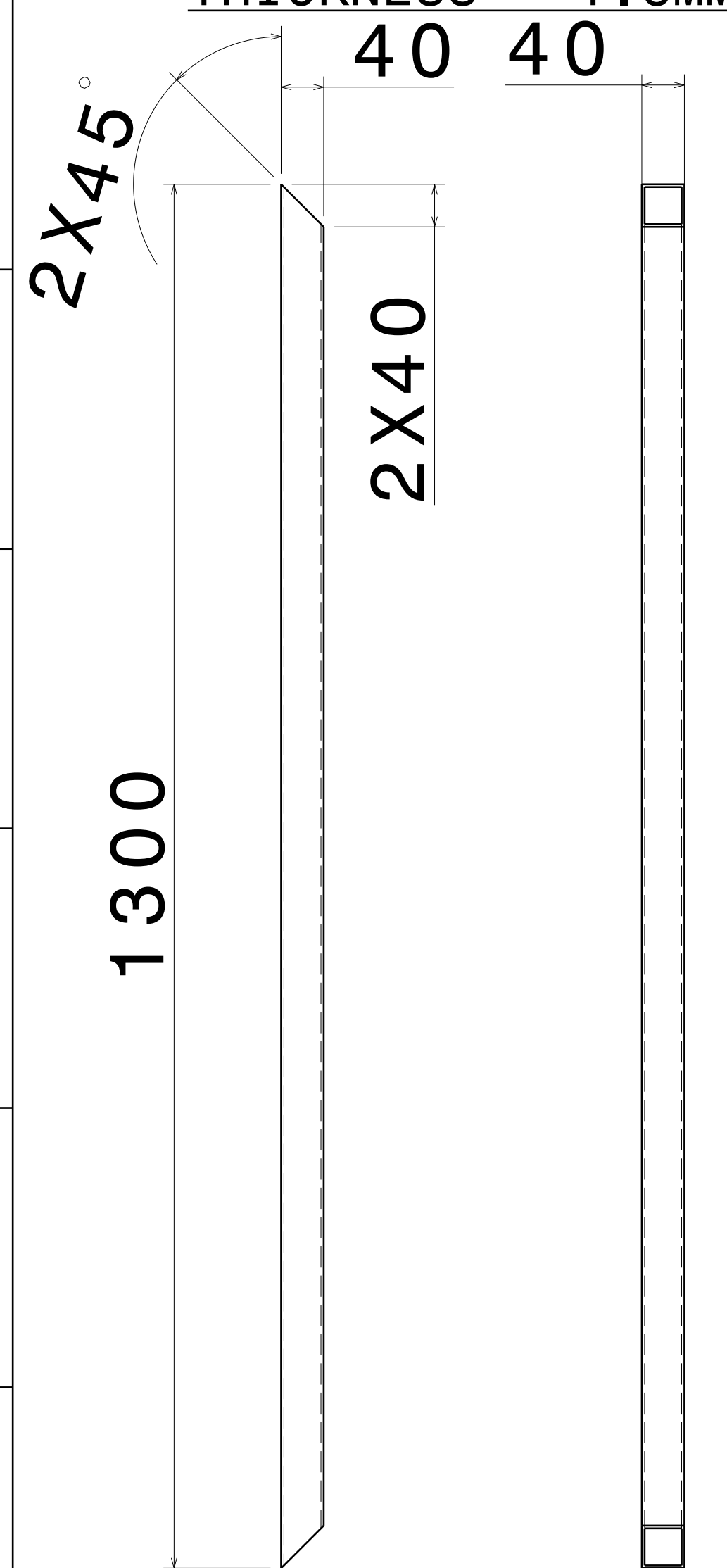

FRONT VIEW RIGHT VIEW  
SCALE: 1:5 SCALE: 1:5

ITEM 20, SHS FRAME 13  
THICKNESS - 2.6MM

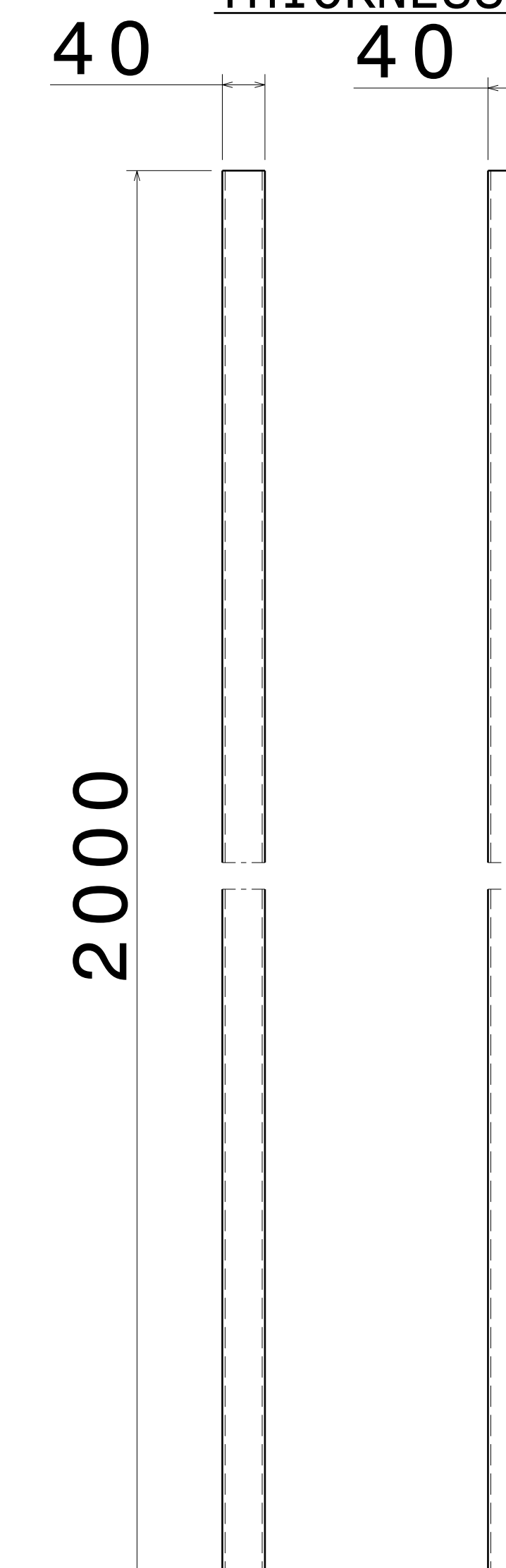

FRONT VIEW RIGHT VIEW  
SCALE: 1:5 SCALE: 1:5

ITEM 21, SHS FRAME 14  
THICKNESS - 2.6MM

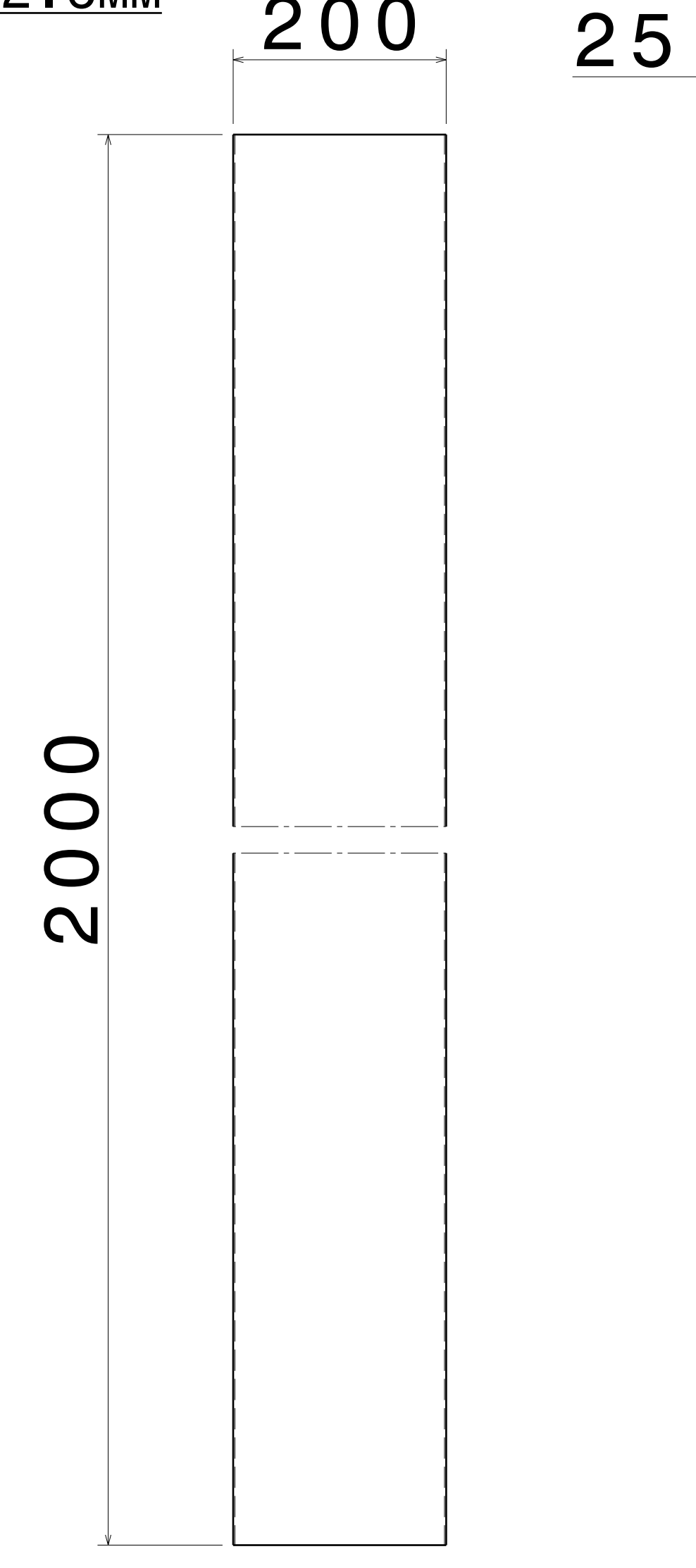

FRONT VIEW RIGHT VIEW  
SCALE: 1:5 SCALE: 1:5

ITEM 22, RHS PLANK 4  
THICKNESS - 1.6MM

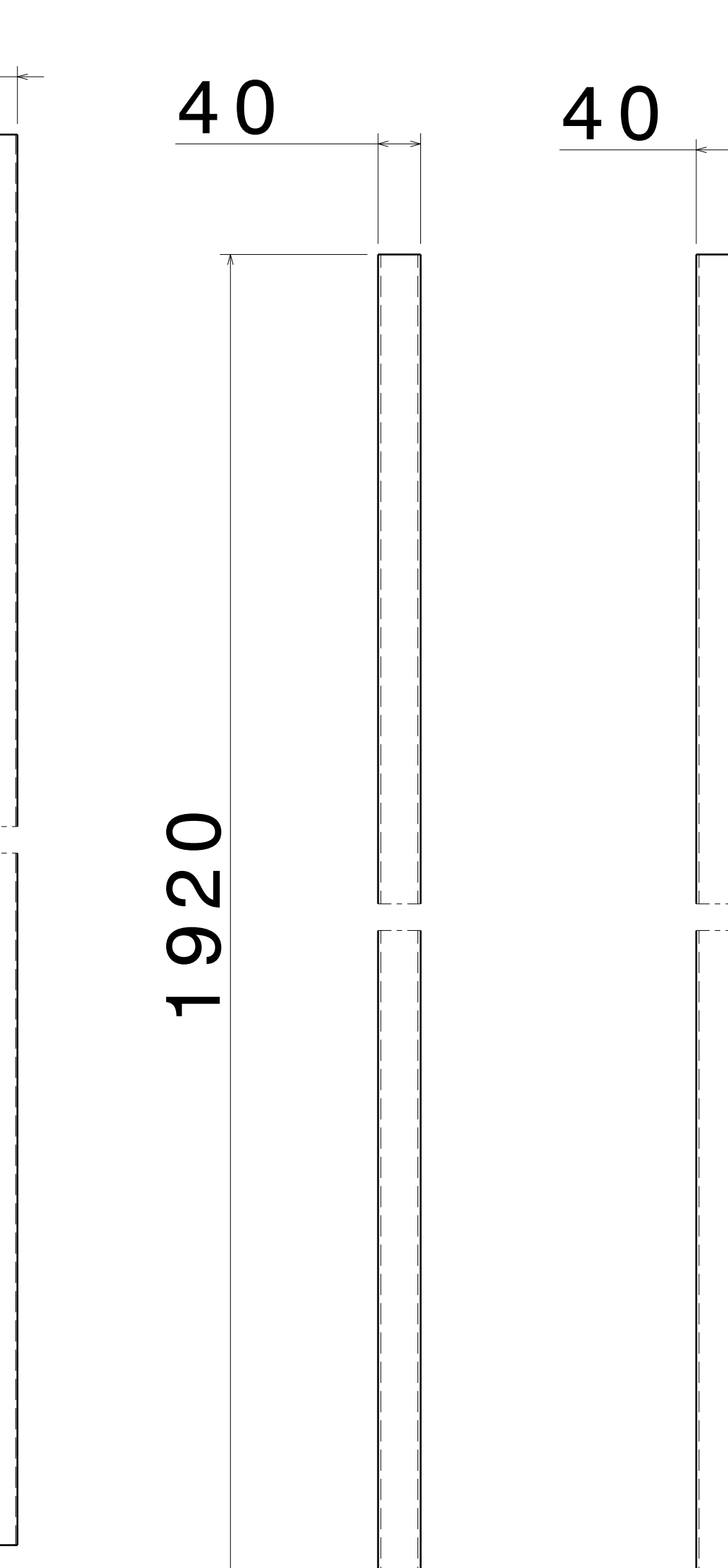

FRONT VIEW RIGHT VIEW  
SCALE: 1:5 SCALE: 1:5

ITEM 23, SHS FRAME 15  
THICKNESS - 2.6MM

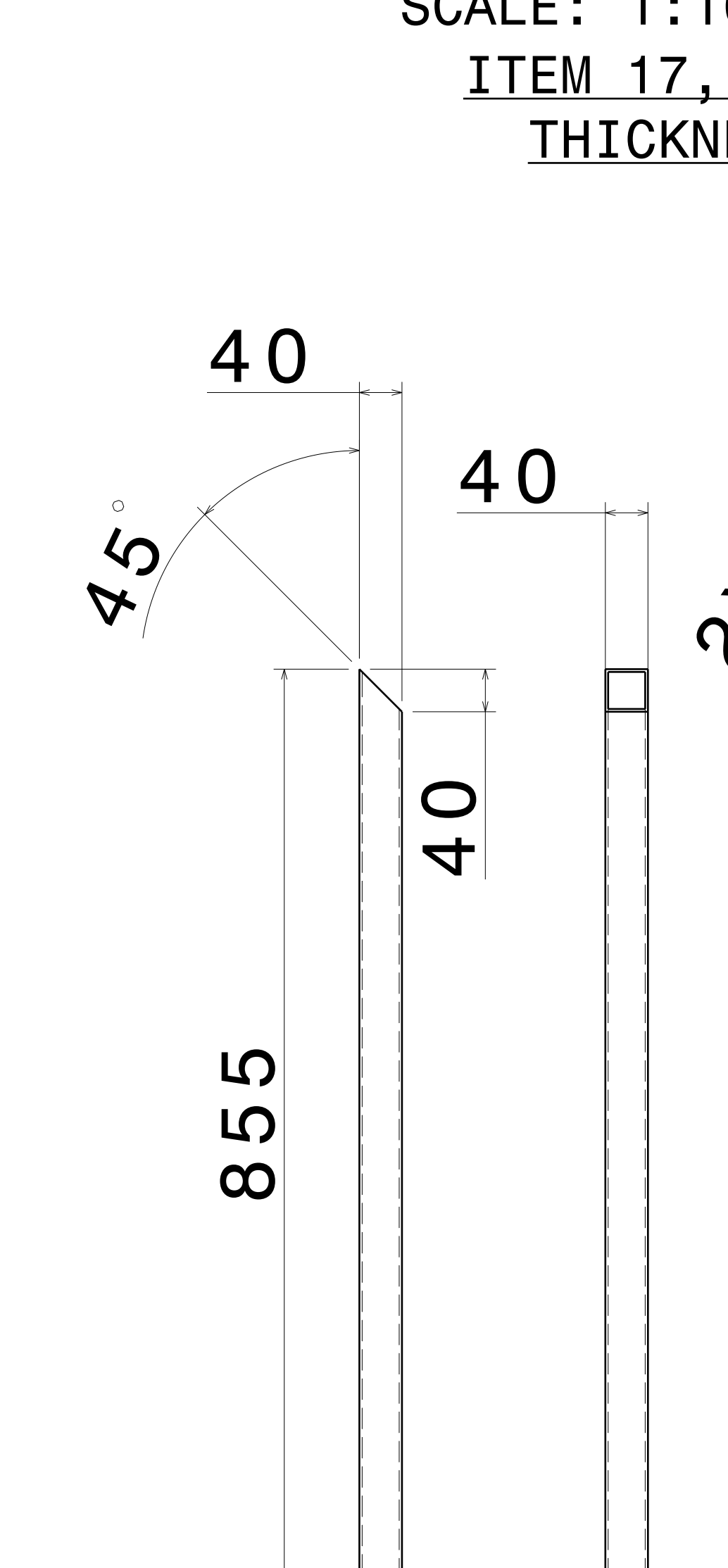

FRONT VIEW RIGHT VIEW  
SCALE: 1:5 SCALE: 1:5

ITEM 24, SHS FRAME 16  
THICKNESS - 2.6MM

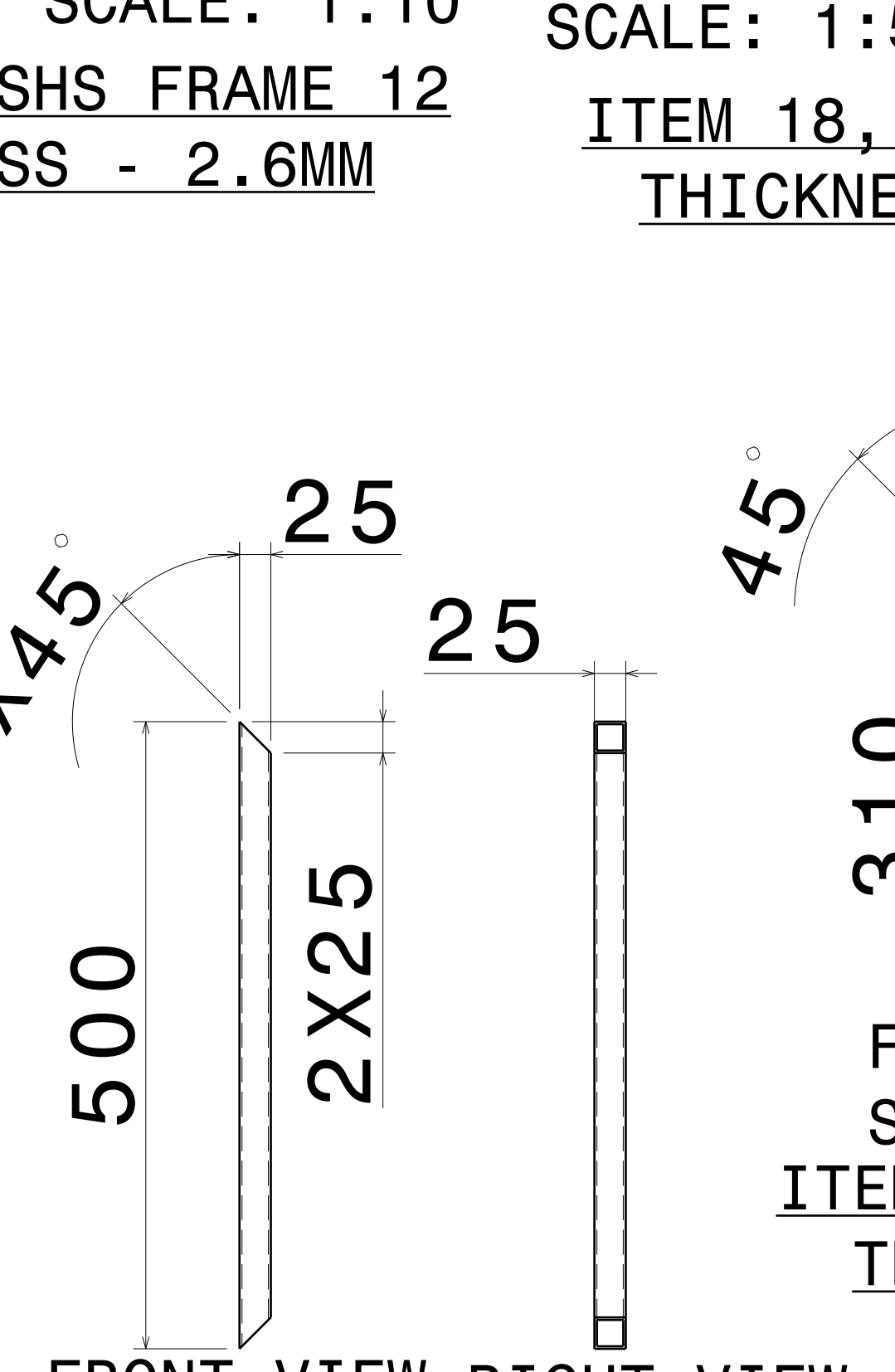

FRONT VIEW RIGHT VIEW  
SCALE: 1:5 SCALE: 1:5

ITEM 25, SHS FRAME 17  
THICKNESS - 2.6MM

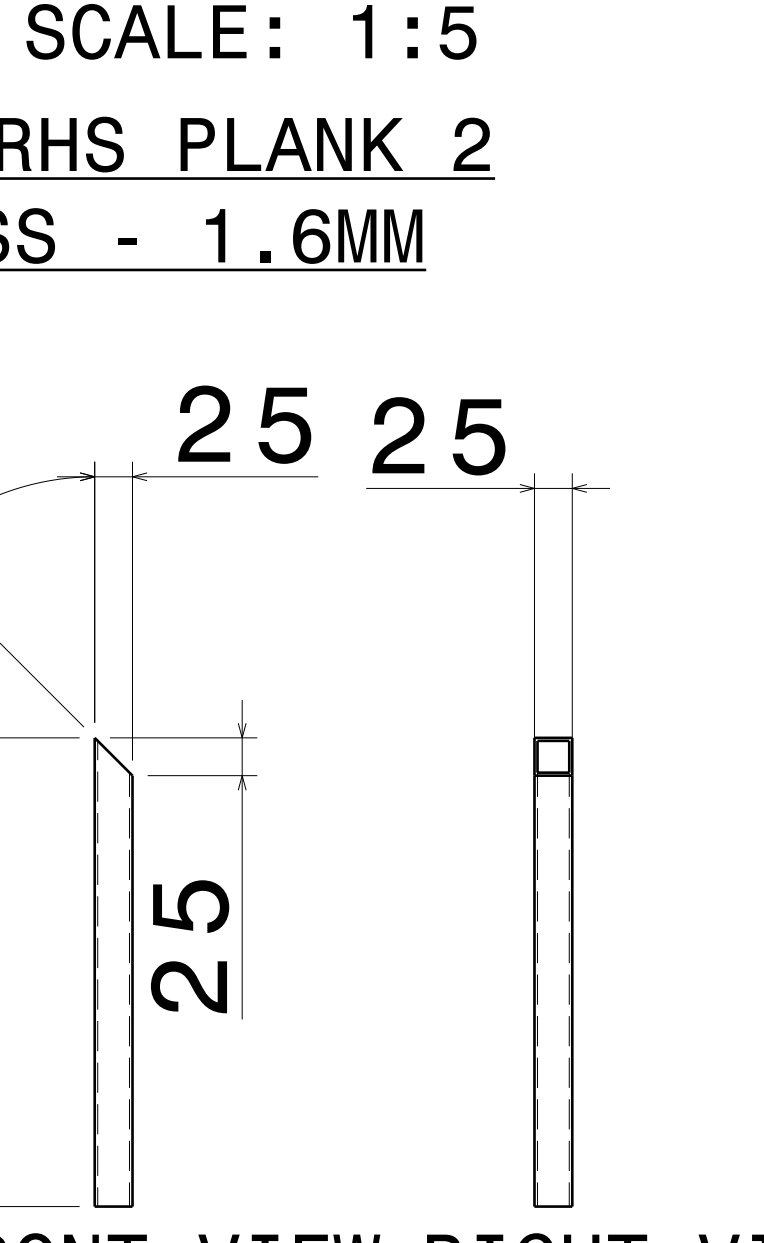

FRONT VIEW RIGHT VIEW  
SCALE: 1:5 SCALE: 1:5

ITEM 26, SHS FRAME 18  
THICKNESS - 2.6MM

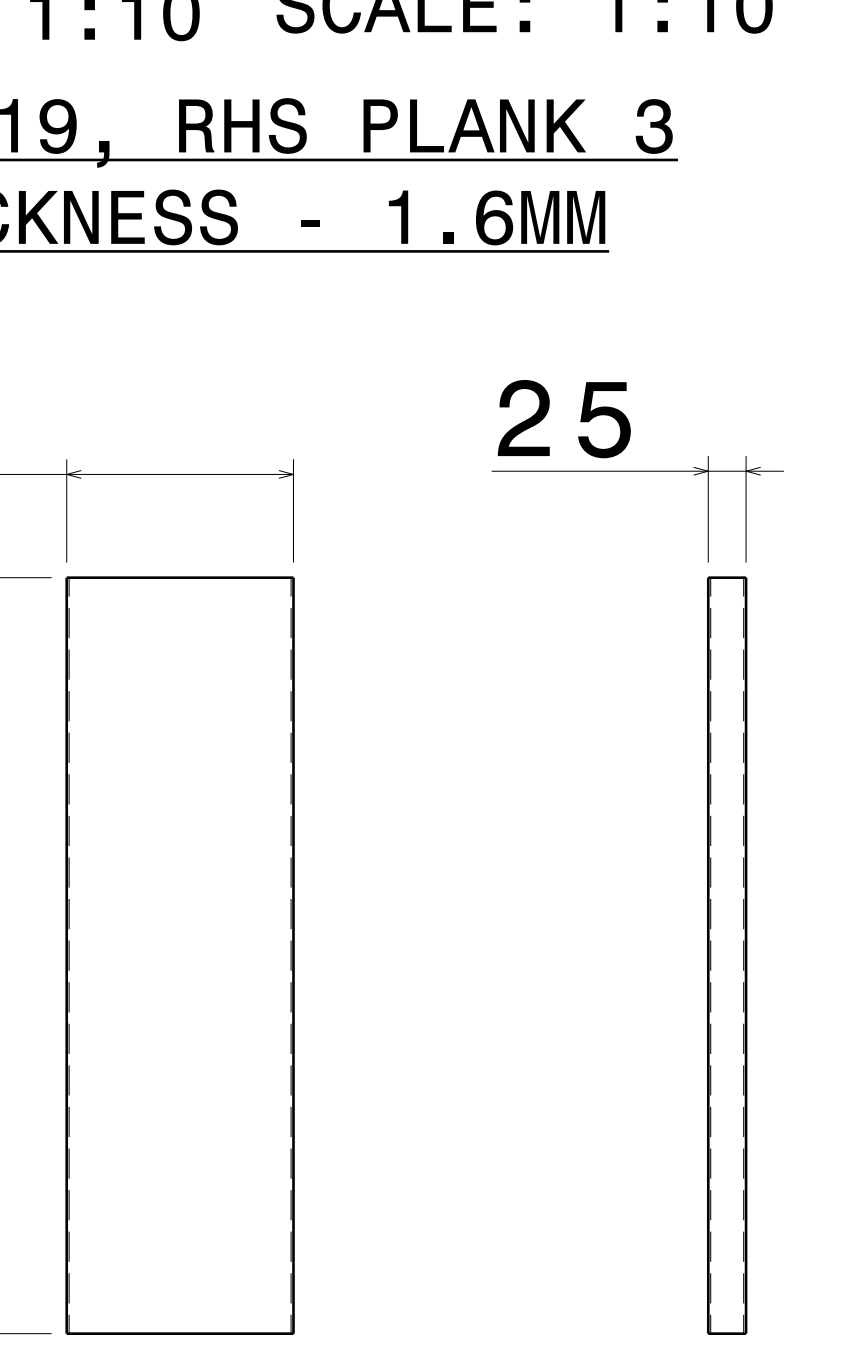

FRONT VIEW RIGHT VIEW  
SCALE: 1:5 SCALE: 1:5

ITEM 27, RHS PLANK 5  
THICKNESS - 1.6MM

UNLESS OTHERWISE SPECIFIED DIMENSION ARE IN MM VIEWS: THIRD ANGLE PROJECTION

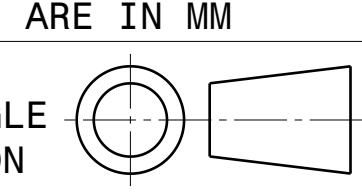

DRAWN BY		DATE	
SB		25JAN2021	
CHECKED BY		DATE	
P2P Analysis & Solutions		25JAN2021	
DESIGNED BY		DATE	
P2P Analysis & Solutions		25JAN2021	

This drawing is our property. It can't be reproduced or communicated without our written agreement.				APL APOLLO TUBES LTD.	
DRAWING TITLE					
JAN 21-11					
SIZE	DRAWING NUMBER		REV		
A0	P2P JAN21-11		00		
SCALE	NONE	WEIGHT (kg)	XXX	SHEET 3 OF 3	