

REV/DATE	DESCRIPTION
00/09MAY2021	INITIAL REVISION

- NOTES:
- (⊥) ALL VERTICAL SUPPORTS ARE PERPENDICULAR.
 - FLATNESS OF .5MM IS APPLIED BY DEFAULT.
 - ⊲ WELD BEAD OF 2MM RADIUS IS FOLLOWED.
 - ▽ SURFACE FINISH MEDIUM TO SMOOTH IS USED.
 - ALL TUBES ARE AS PER APL APOLLO STANDARD. CHANGES MAY EFFECT THE LOAD CAPACITY.
 - ALL HORIZONTAL AND VERTICAL TUBES ARE PERPENDICULAR TO EACH OTHER WITH ±1 DEG.
 - FINE WELDING IS REQUIRED AS PER MENTIONED DETAILS AND FINISHING.
 - HIGHER CURRENT WELDING MAY AFFECT THE BRITTLENESS OF MATERIAL WHICH LATER MAY RAISE TO WEAKENING OF STRUCTURE.
 - FABRICATORS ARE ALLOWED TO USE FITTINGS/FRAMES/SUPPORTS AS NEEDED AND THE SAME MUST BE COMMUNICATED BACK TO ENGINEERING TEAM.
 - BOP COMPONENT WEIGHTS ARE FOR REFERENCE ONLY AND SUBJECTED TO CHANGE PER PURCHASED COMPONENTS.

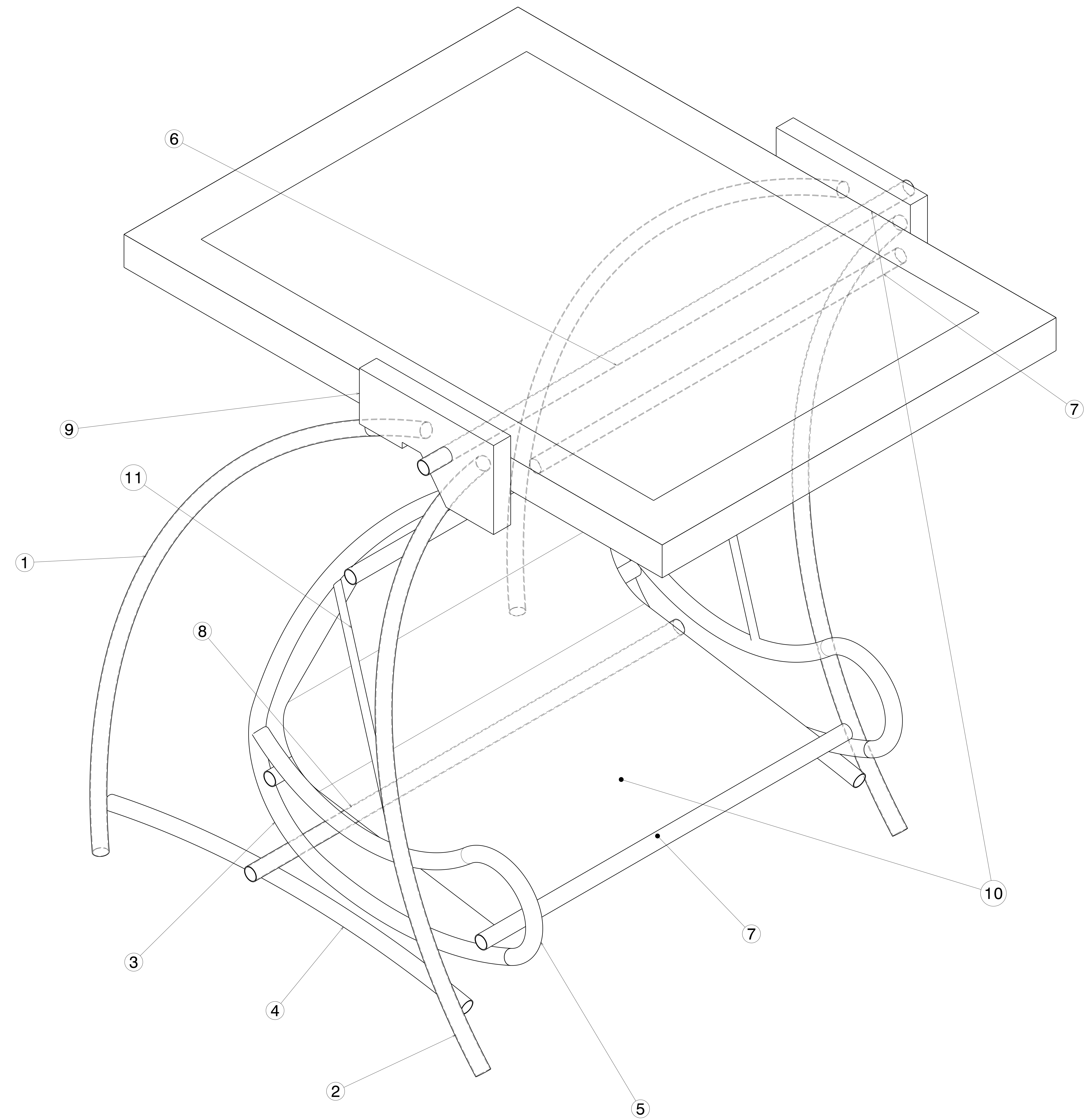

Isometric view
Scale: 1:4

ITEM NO.	ROD	PART NUMBER	DESCRIPTION	QTY.	Wt (kg) /Each
11	ROD 9		DIA 21.3 X 1.6 THK X 740	2	0.57
10	LEATHER/REXIN - BOP		-----	AS NEEDED	-----
9	JOINER - BOP		-----	AS NEEDED	-----
8	ROD 8		DIA 42.4 X 2THK X 1500	1	3
7	ROD 7		DIA 42.4 X 2THK X 1280	4	2.55
6	ROD 6		DIA 42.4 X 2THK X 1700	1	3.4
5	ROD 5		DIA 42.4 X 2THK X 1300	2	2.6
4	ROD 4		DIA 42.4 X 2THK X 1260	2	2.5
3	ROD 3		DIA 42.4 X 2THK X 2850	2	5.7
2	ROD 2		DIA 42.4 X 2THK X 2025	2	4.05
1	ROD 1		DIA 42.4 X 2THK X 2340	2	4.65

This drawing is our property. It can't be reproduced or communicated without our written agreement.
www.p2p.ind.in

APL APOLLO TUBES LTD.

DRAWING TITLE: **SWING**

DRAWN BY: SB	DATE: 09MAY2021	SIZE: A0	DRAWING NUMBER: P2P MAY 21-12	REV: 00
CHECKED BY: P2P Analysis & Solutions	DATE: 09MAY2021	SCALE: As Indicated	WEIGHT (kg): 0kg	SHEET 1 OF 3
DESIGNED BY: P2P Analysis & Solutions	DATE: 09MAY2021			

UNLESS OTHERWISE SPECIFIED DIMENSION ARE IN MM
VIEWS: THIRD ANGLE PROJECTION

REV	DATE	DESCRIPTION
00	09MAY2021	INITIAL REVISION

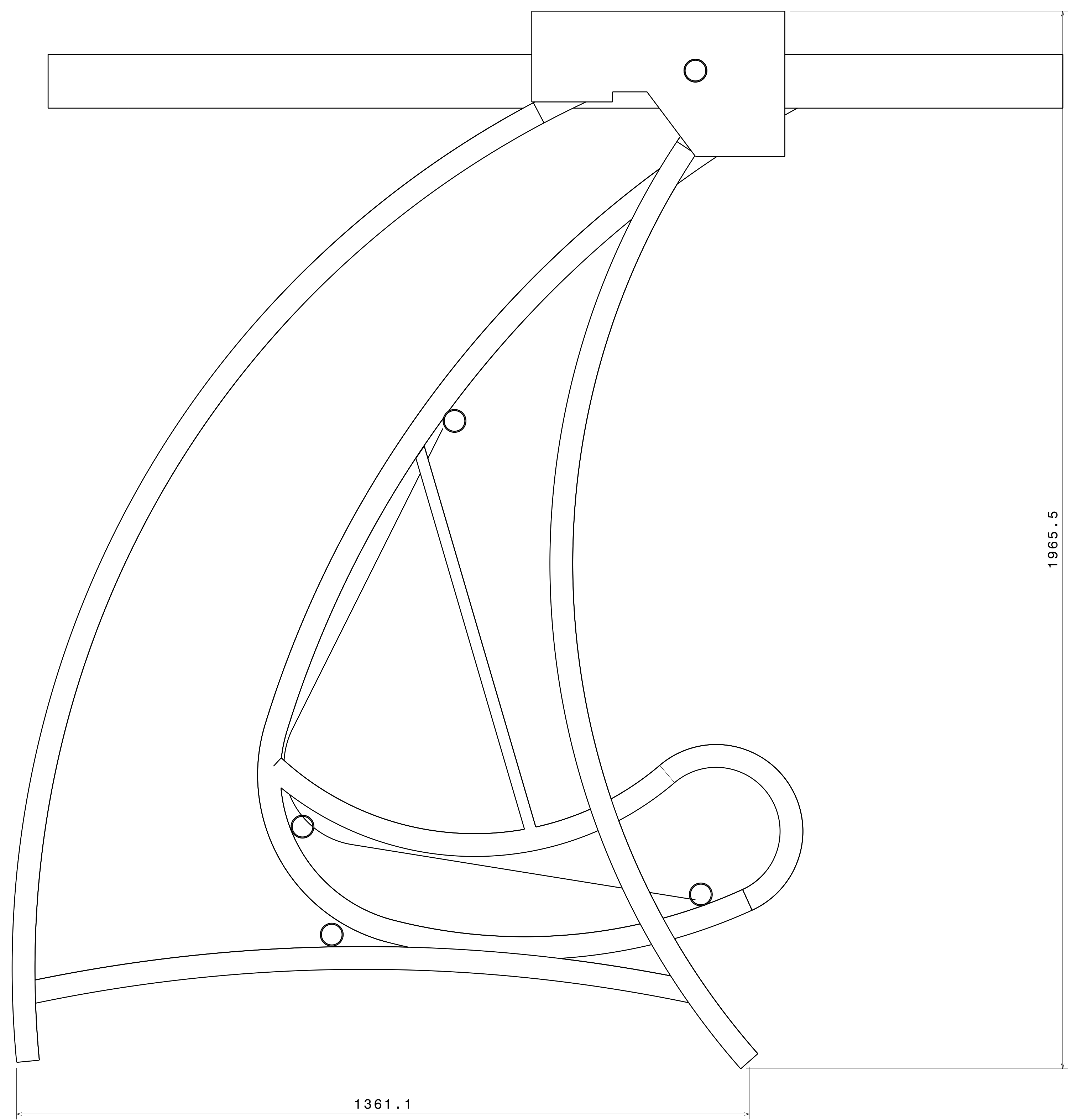

Front view
Scale: 1:5

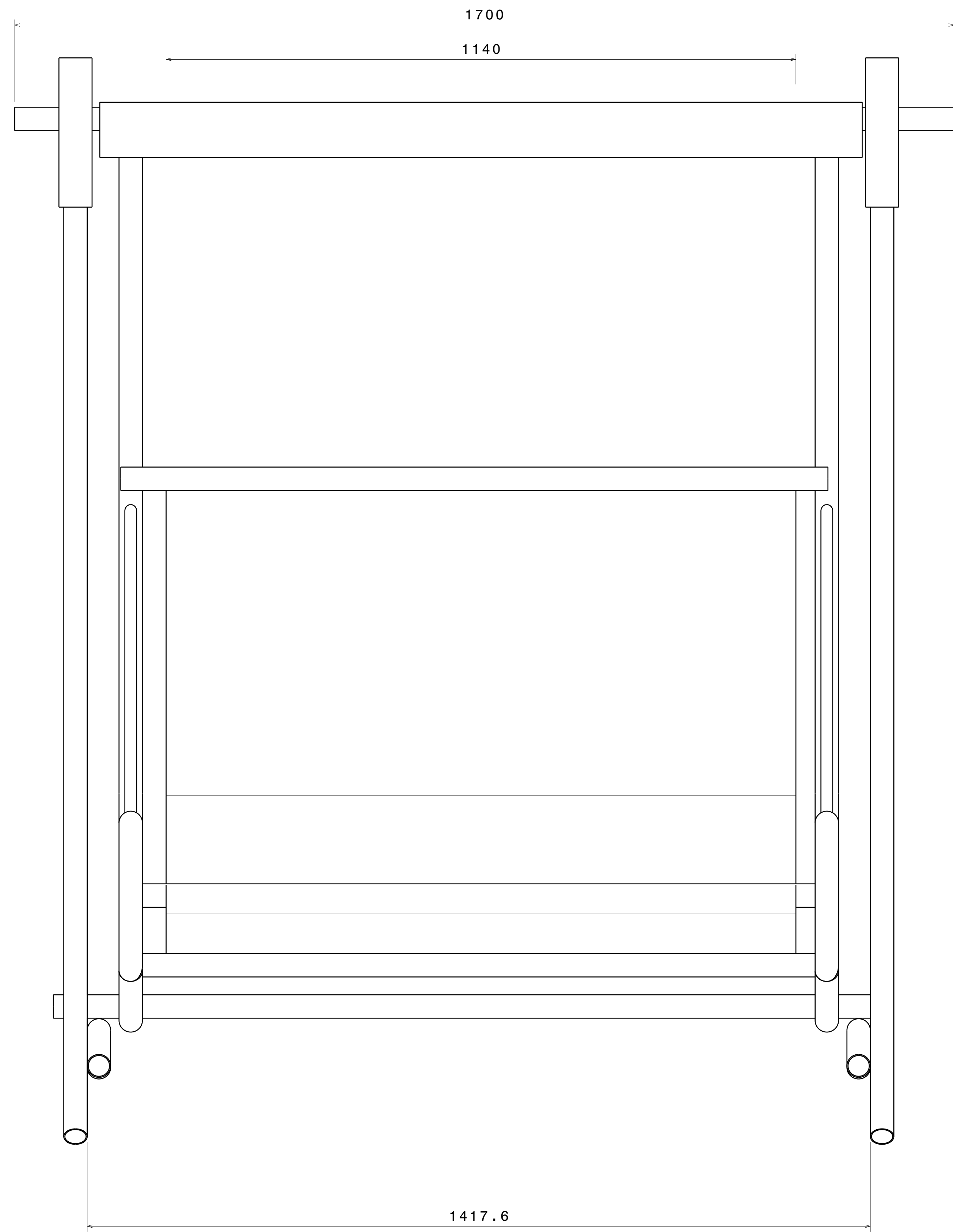

Right view
Scale: 1:5

UNLESS OTHERWISE SPECIFIED DIMENSION ARE IN MM VIEWS: THIRD ANGLE PROJECTION

This drawing is our property. It can't be reproduced or communicated without our written agreement. www.p2p.ind.in

DRAWN BY	DATE
SB	09MAY2021
CHECKED BY	DATE
P2P Analysis & Solutions	09MAY2021
DESIGNED BY	DATE
P2P Analysis & Solutions	09MAY2021

APL APOLLO TUBES LTD.	
DRAWING TITLE	
SWING	
SIZE	DRAWING NUMBER
A0	P2P MAY 21-12
SCALE	WEIGHT (kg)
NONE	XXX
REV	SHEET 2 OF 3
00	

REV	DATE	DESCRIPTION
00	09MAY2021	INITIAL REVISION

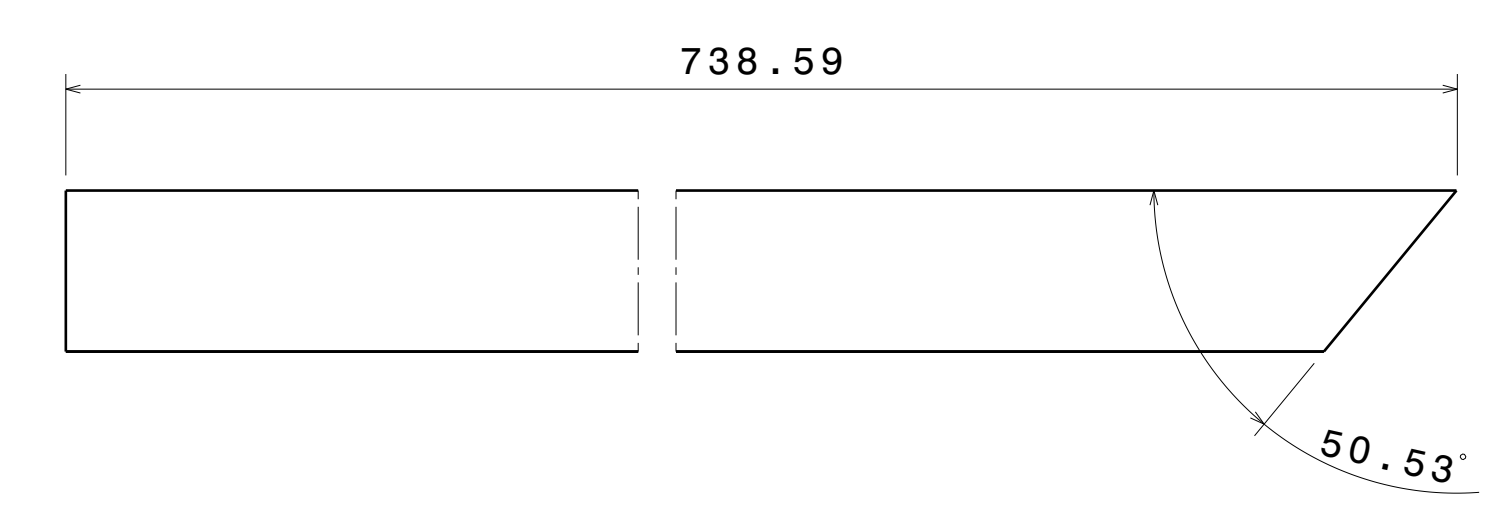
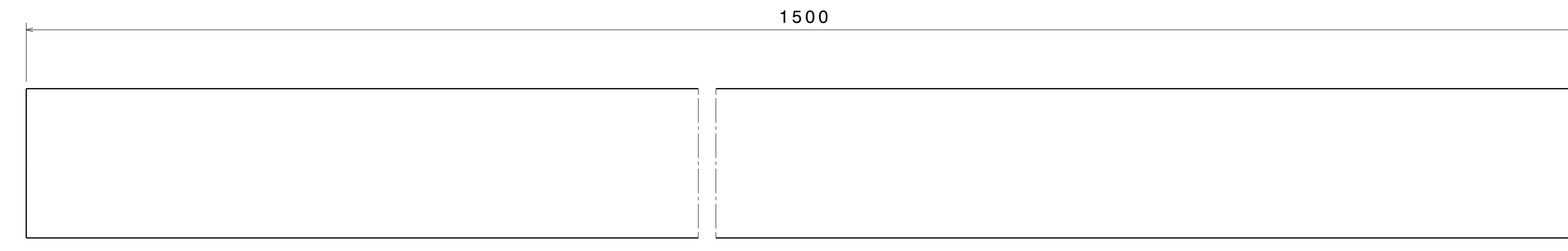
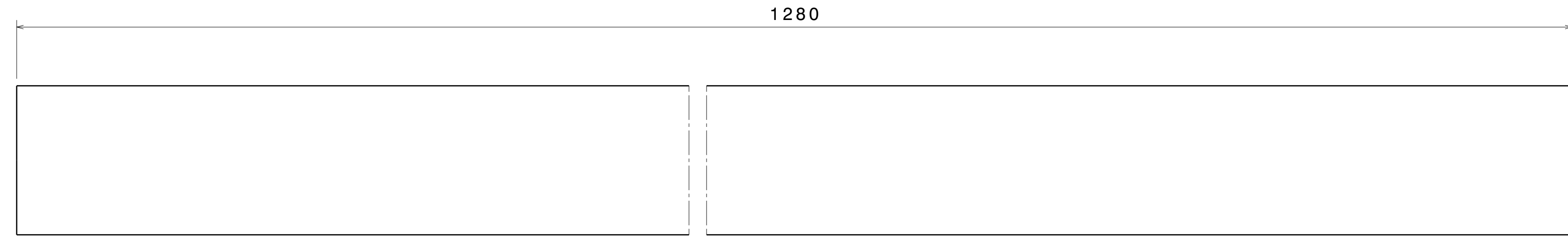
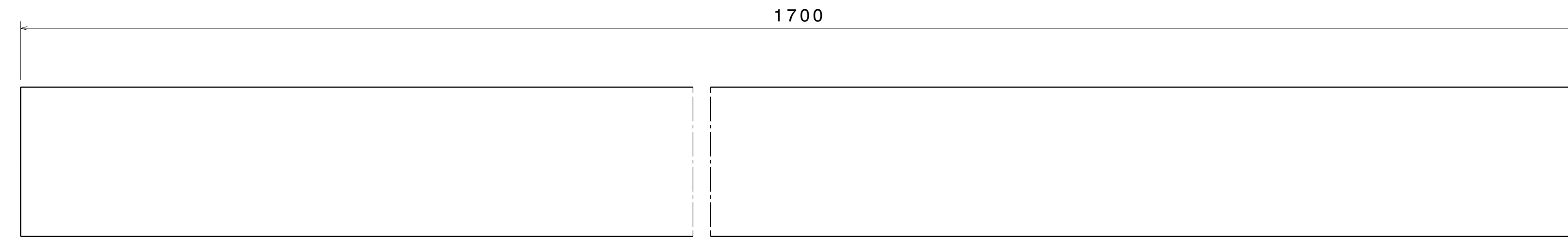
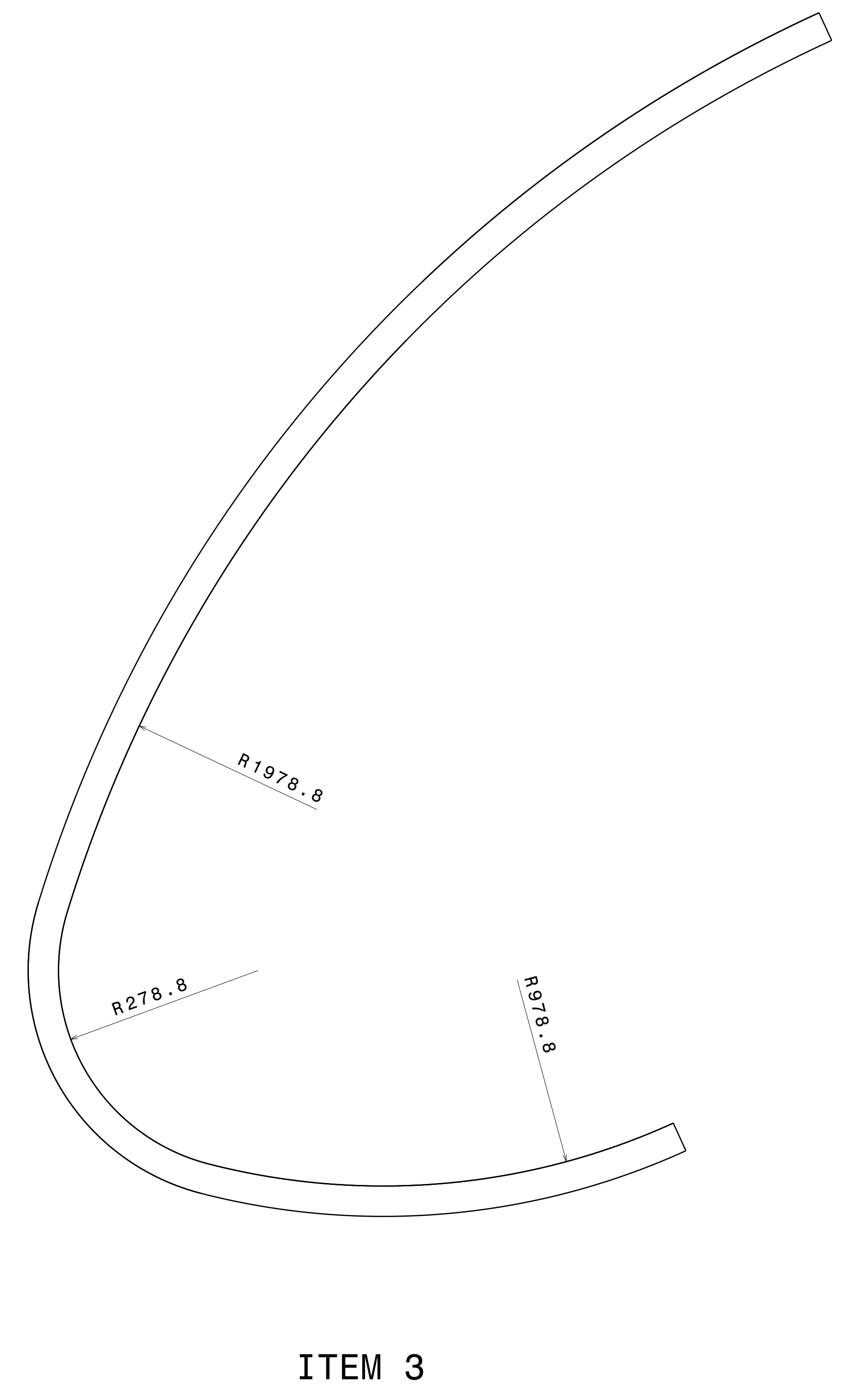
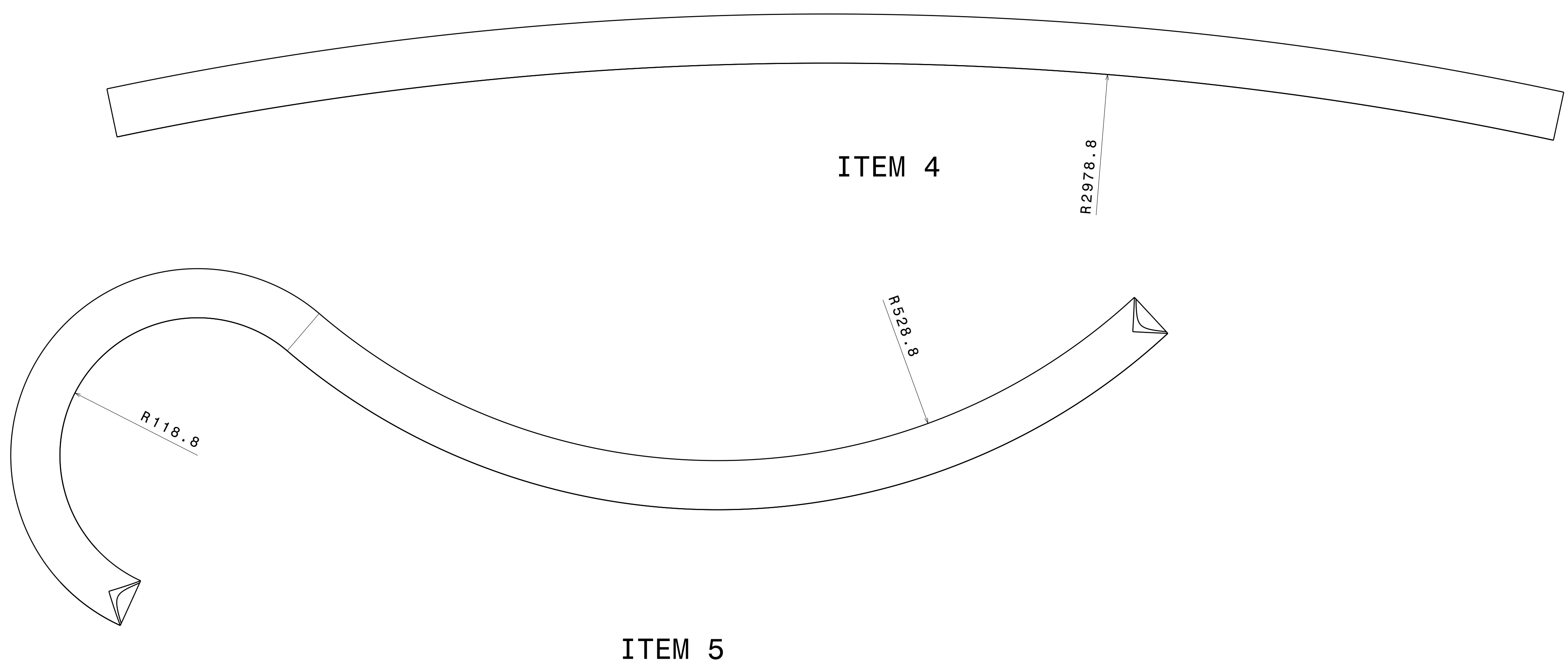
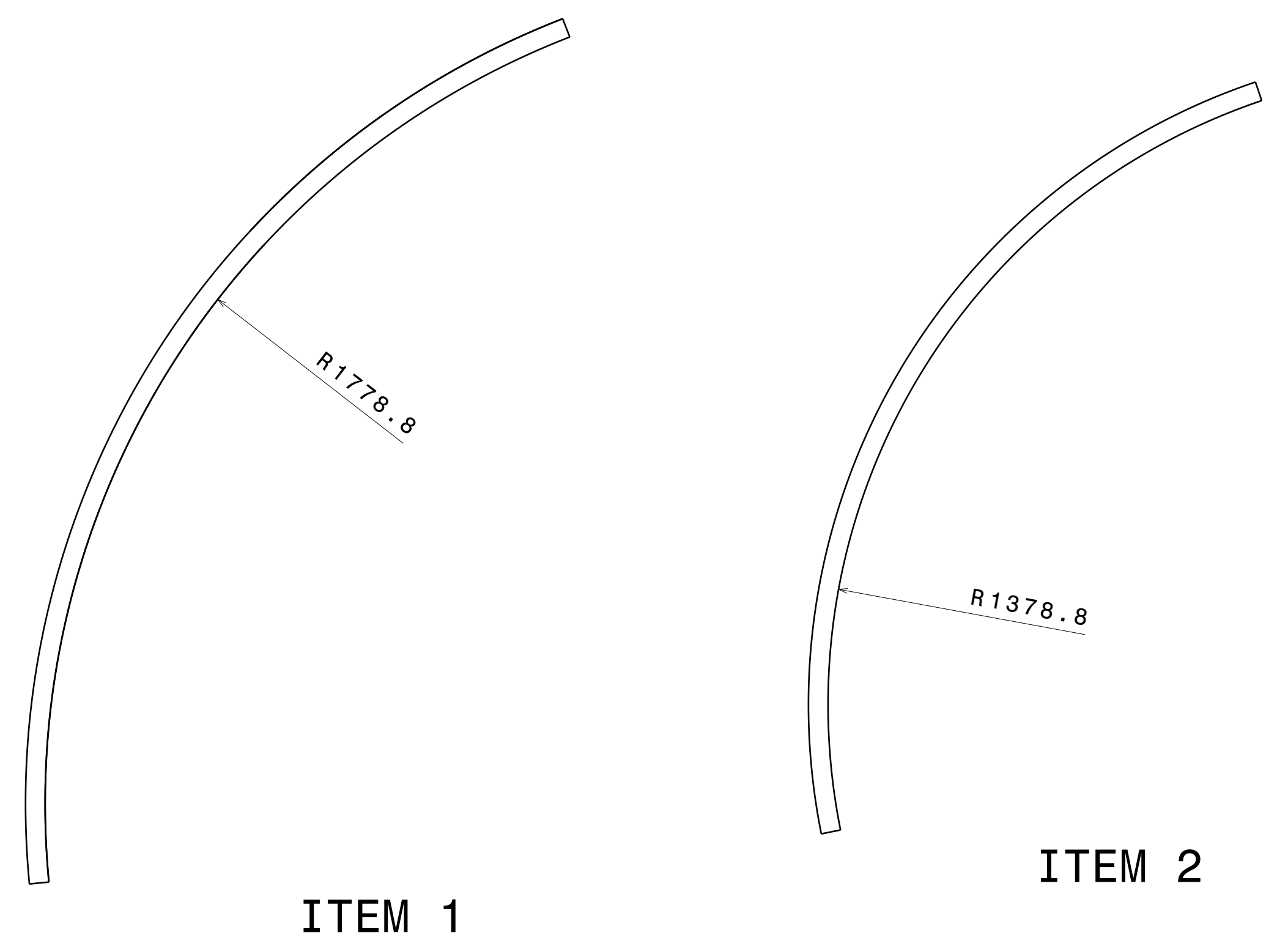

UNLESS OTHERWISE SPECIFIED DIMENSION ARE IN MM
 VIEWS: THIRD ANGLE PROJECTION

This drawing is our property. It can't be reproduced or communicated without our written agreement.
 www.p2p.ind.in

DRAWN BY: SB
 CHECKED BY: P2P Analysis & Solutions
 DESIGNED BY: P2P Analysis & Solutions

DATE: 09MAY2021		DRAWING TITLE: SWING	
SIZE: A0	DRAWING NUMBER: P2P MAY 21-12	REV: 00	
SCALE: NONE	WEIGHT (kg): XXX	SHEET 3 OF 3	

