

REV/DATE	DESCRIPTION
00 / 22NOV2020	INITIAL REVISION

- NOTES:
- (⊥) ALL VERTICAL SUPPORTS ARE PERPENDICULAR.
  - FLATNESS OF .5MM IS APPLIED BY DEFAULT.
  - ⊥ WELD BEAD OF 2MM RADIUS IS FOLLOWED.
  - ▽ SURFACE FINISH MEDIUM TO SMOOTH IS USED.
  - ALL TUBES ARE AS PER APL APOLLO STANDARD. CHANGES MAY EFFECT THE LOAD CAPACITY.
  - ALL HORIZONTAL AND VERTICAL TUBES ARE PERPENDICULAR TO EACH OTHER WITH ±1 DEG.
  - FINE WELDING IS REQUIRED AS PER MENTIONED DETAILS AND FINISHING.
  - HIGHER CURRENT WELDING MAY AFFECT THE BRITTLENESS OF MATERIAL WHICH LATER MAY RAISE TO WEAKENING OF STRUCTURE.
  - FABRICATORS ARE ALLOWED TO USE FITTINGS/FRAMES/SUPPORTS AS NEEDED AND THE SAME MUST BE COMMUNICATED BACK TO ENGINEERING TEAM.
  - BOP COMPONENT WEIGHTS ARE FOR REFERENCE ONLY AND SUBJECTED TO CHANGE PER PURCHASED COMPONENTS.

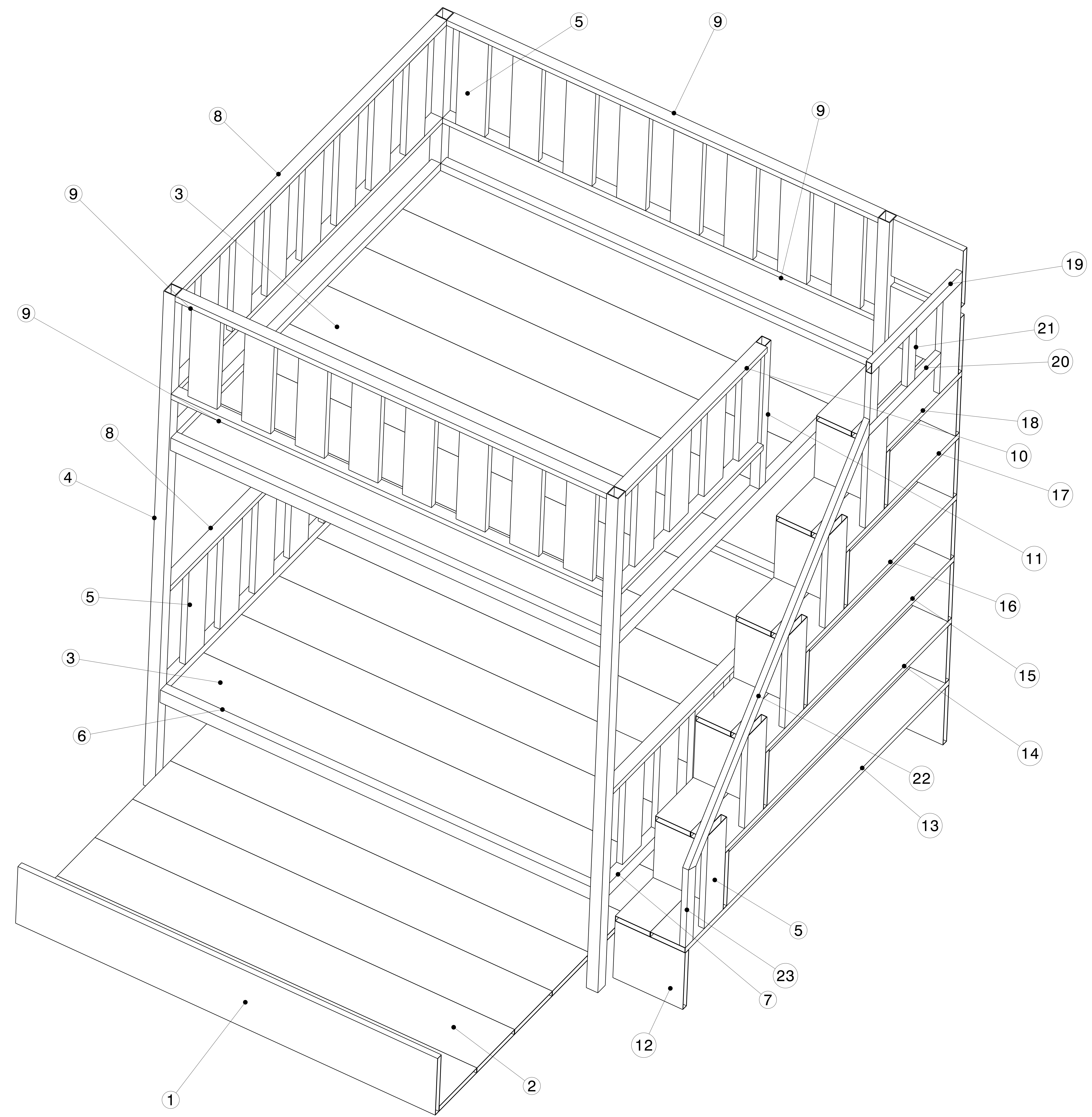

Isometric view

ITEM NO.	PART NUMBER	DESCRIPTION	QTY.	Wt (Kg)/Each
23	RECT TUBE 10	50 X 25 X 2 X 378	1	.825
22	RECT TUBE 9	50 X 25 X 2 X 1757.5	1	3.84
21	RECT TUBE 8	50 X 25 X 2 X 250	2	0.6
20	RECT TUBE 7	50 X 25 X 2 X 475	1	1.06
19	RECT TUBE 6	50 X 25 X 2 X 600	1	1.34
18	RHS PLANK 11	150 X 25 X 1.6 X 500	2	4.4
17	RHS PLANK 10	150 X 25 X 1.6 X 750	2	6.56
16	RHS PLANK 9	150 X 25 X 1.6 X 1000	2	7.64
15	RHS PLANK 8	150 X 25 X 1.6 X 1250	2	8.72
14	RHS PLANK 7	150 X 25 X 1.6 X 1500	2	9.8
13	RHS PLANK 6	150 X 25 X 1.6 X 1750	2	5.19
12	RHS PLANK 5	275 X 25 X 1.6 X 300	14	2.24
11	SO FRAME 2	40 X 40 X 2 X 695	1	1.66
10	RECT TUBE 5	50 X 25 X 2 X 940	2	2.1
9	RECT TUBE 4	50 X 25 X 2 X 1850.5	4	4.13
8	RECT TUBE 3	50 X 25 X 2 X 1750.6	4	3.9
7	RECT TUBE 2	60 X 40 X 2.6 X 1750.6	4	6.8
6	RECT TUBE 1	60 X 40 X 2.6 X 1850	4	7.2
5	RHS PLANK 4	125 X 25 X 1.6 X 450	47	1.6
4	SO FRAME 1	49.5 X 49.5 X 2.9 X 2400	4	10.2
3	RHS PLANK 3	250 X 25 X 1.6 X 1850	14	12.65
2	RHS PLANK 2	250 X 25 X 1.6 X 1800	7	12.3
1	RHS PLANK 1	275 X 25 X 1.6 X 1800	2	13.44

This drawing is our property. It can't be reproduced or communicated without our written agreement.

**APL APOLLO TUBES LTD.**

DRAWING TITLE: **NOV 20 04**

SCALE: **As Indicated** WEIGHT (kg): **0kg** SHEET **1 OF 3**

UNLESS OTHERWISE SPECIFIED DIMENSION ARE IN MM VIEWS: THIRD ANGLE PROJECTION

CHECKED BY: P2P Analysis & Solutions DATE: 22NOV2020

DESIGNED BY: P2P Analysis & Solutions DATE: 22NOV2020

APL APOLLO TUBES LTD. NOV 20 04 P2P NOV 20 04 00



REV	DATE	DESCRIPTION
00	22NOV2020	INITIAL REVISION

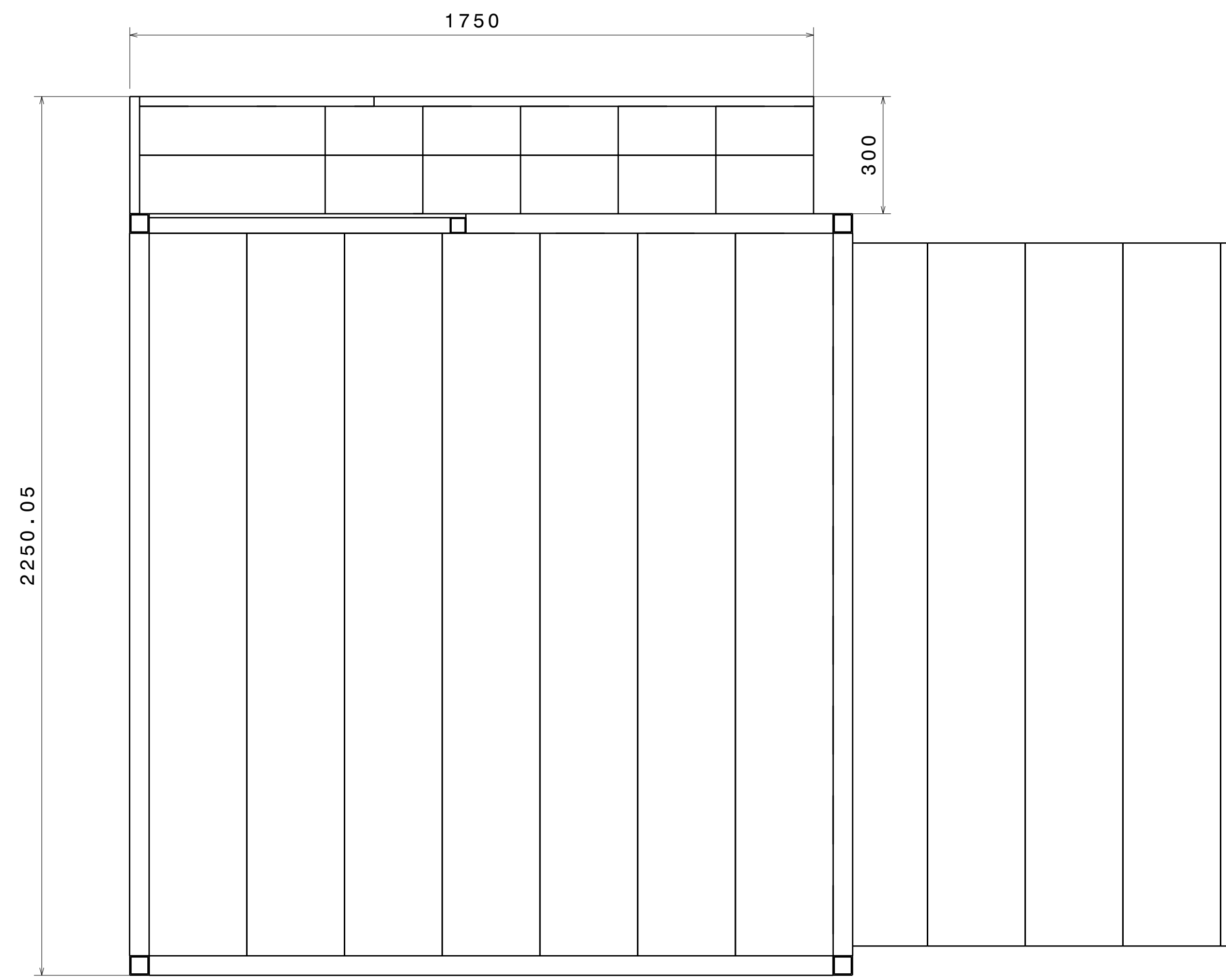

Top view  
Scale: 1:10

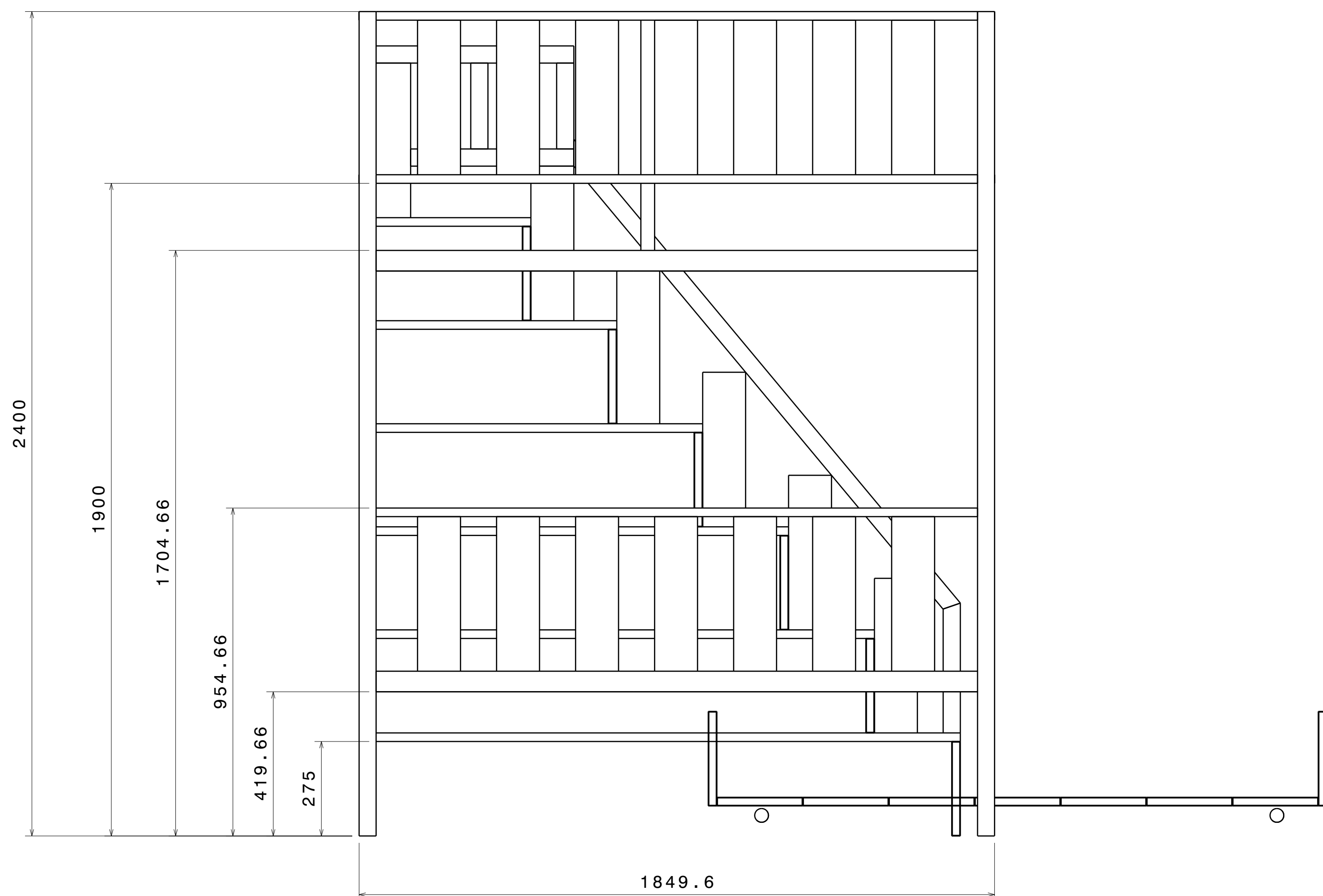

Front view  
Scale: 1:10

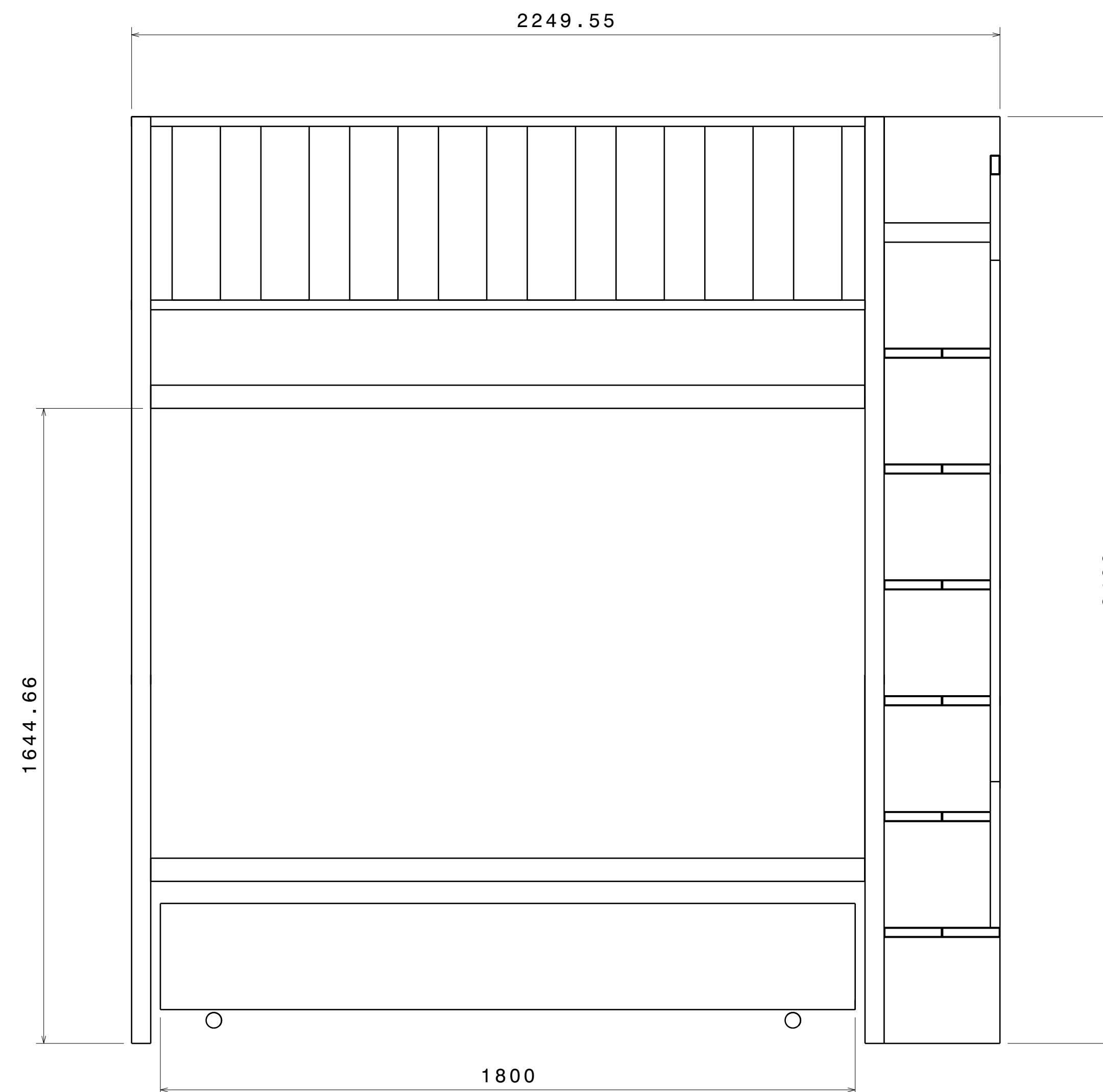

Right view  
Scale: 1:10

UNLESS OTHERWISE SPECIFIED DIMENSION ARE IN MM  
VIEWS: THIRD ANGLE PROJECTION

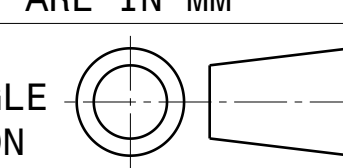

This drawing is our property. It can't be reproduced or communicated without our written agreement.

APL APOLLO TUBES LTD. 

DRAWN BY	DATE
SB	22NOV2020
CHECKED BY	DATE
P2P Analysis & Solutions	22NOV2020
DESIGNED BY	DATE
P2P Analysis & Solutions	22NOV2020

DRAWING TITLE			
NOV 20 04			
SIZE	DRAWING NUMBER	REV	
A0	P2P NOV 20 04	00	
SCALE	NONE	WEIGHT (kg)	XXX
			SHEET 2 OF 3

REV	DATE	DESCRIPTION
00	22NOV2020	INITIAL REVISION

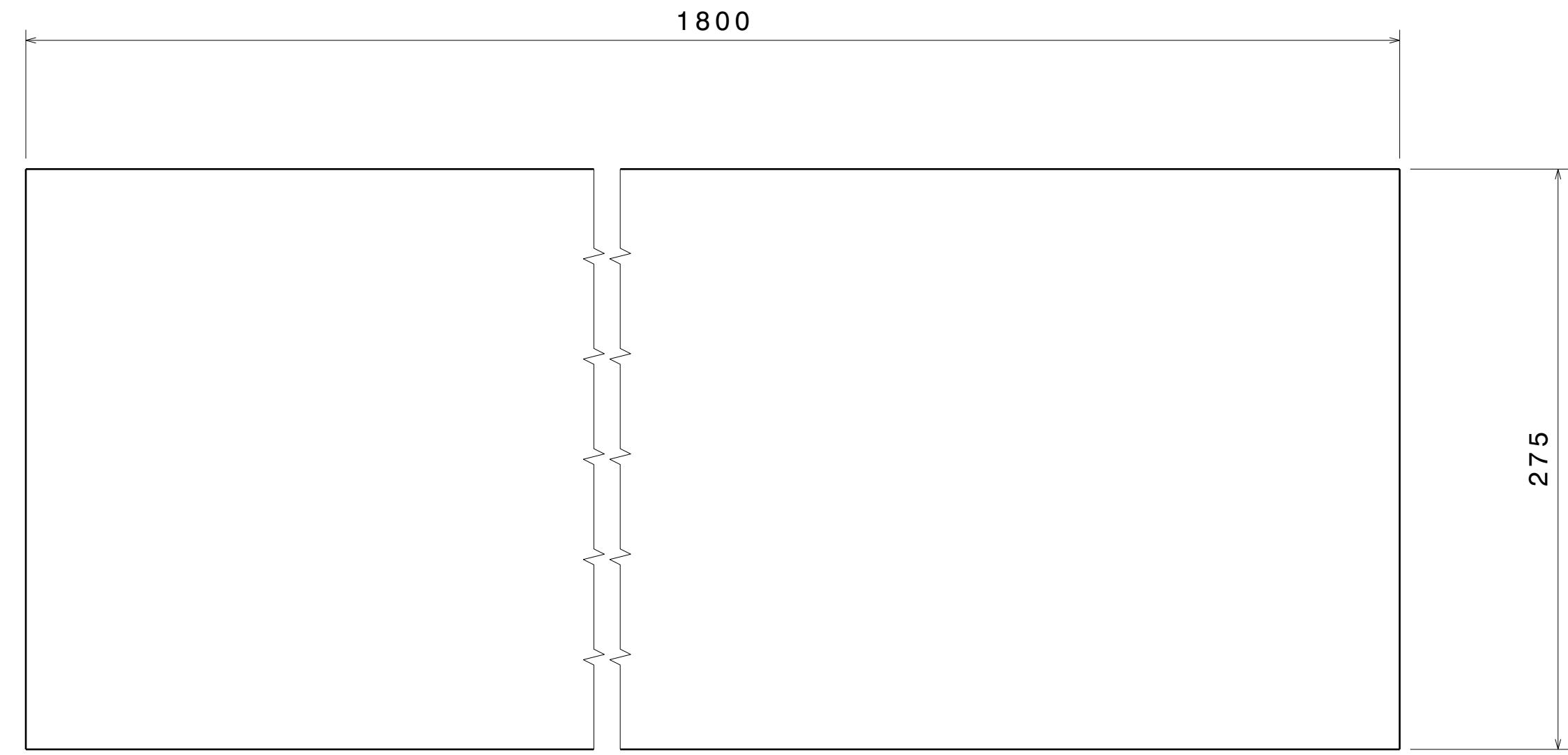

ITEM 1, PLANK

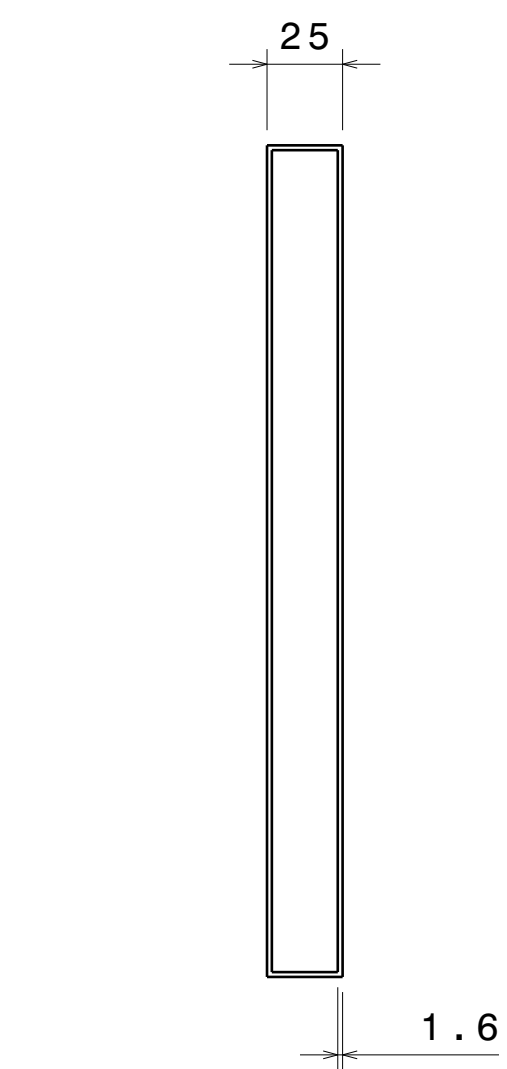

Right view  
Scale: 2:5

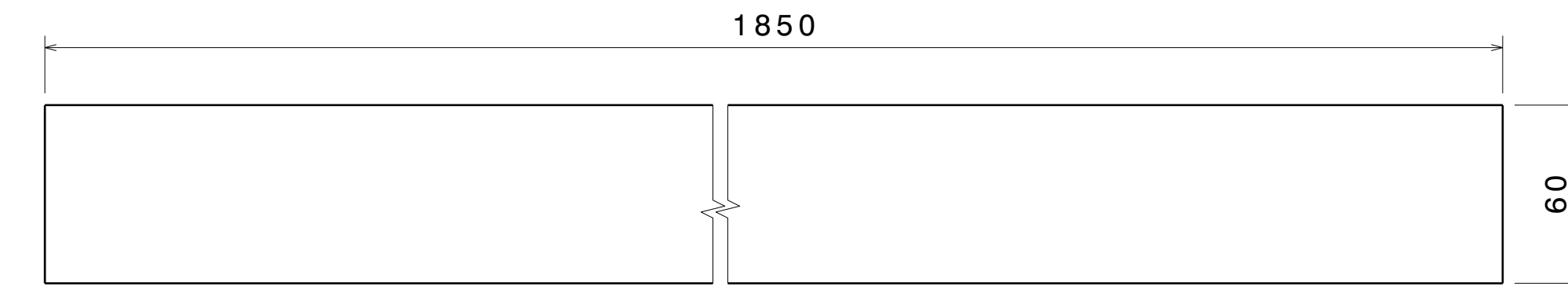

ITEM 6

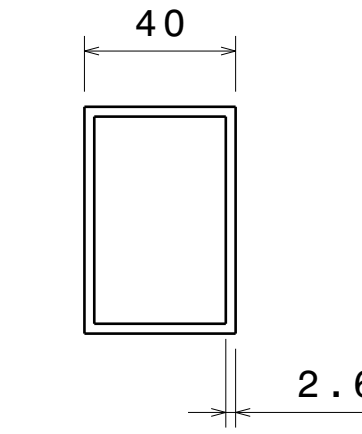

Right view  
Scale: 1:2

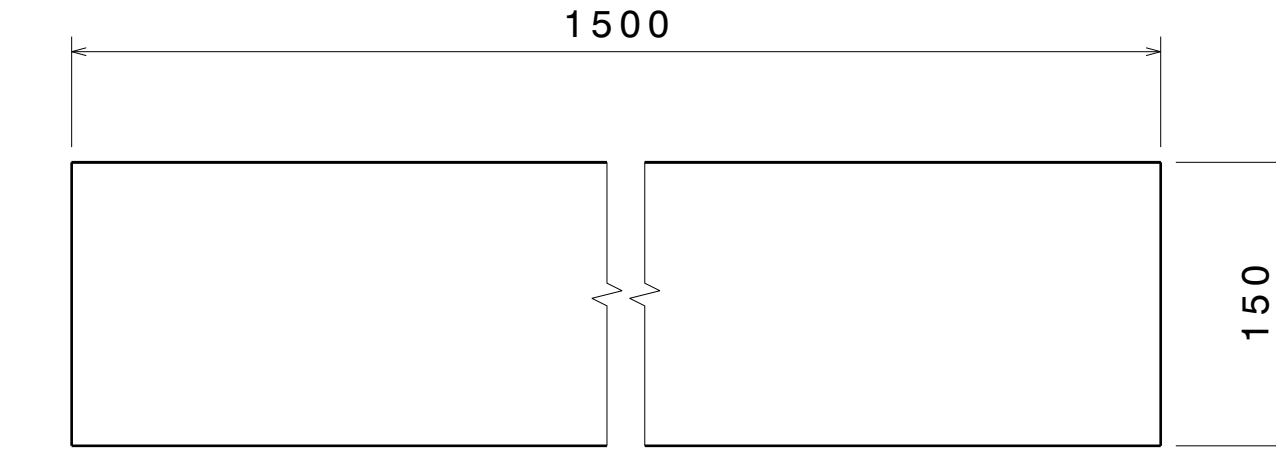

ITEM 14

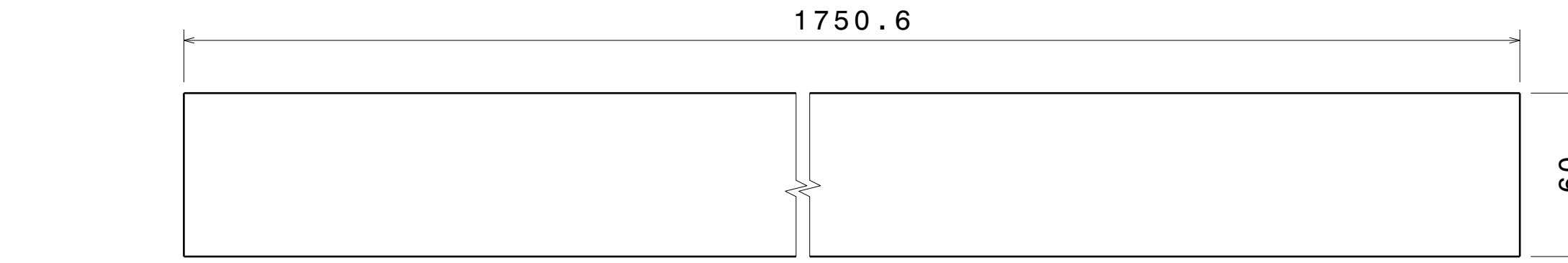

ITEM 7

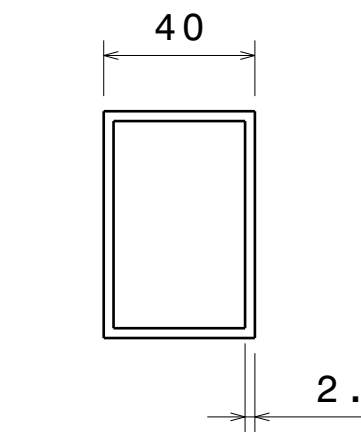

Right view[4]  
Scale: 1:2

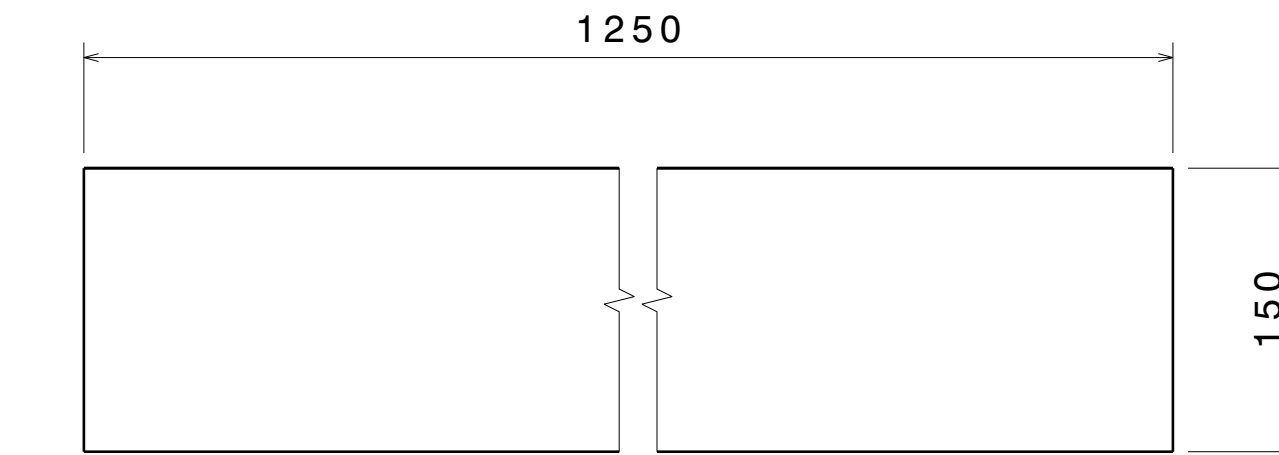

ITEM 15

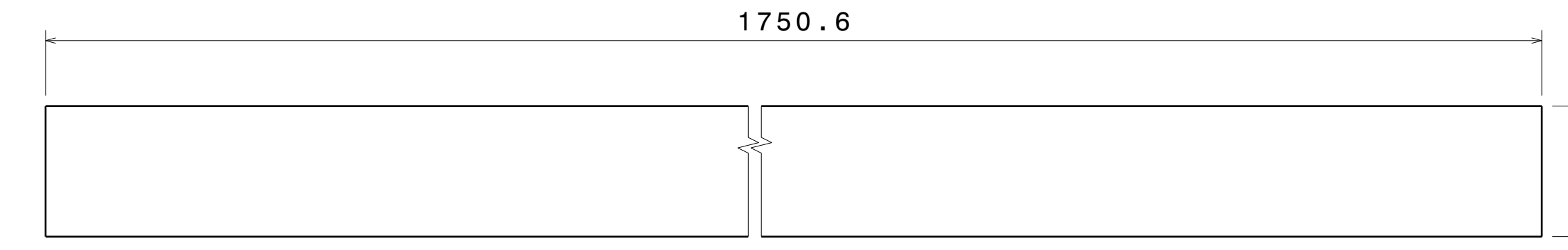

ITEM 8

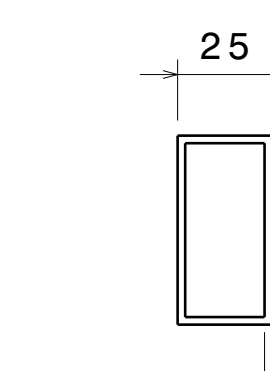

Right view  
Scale: 1:2

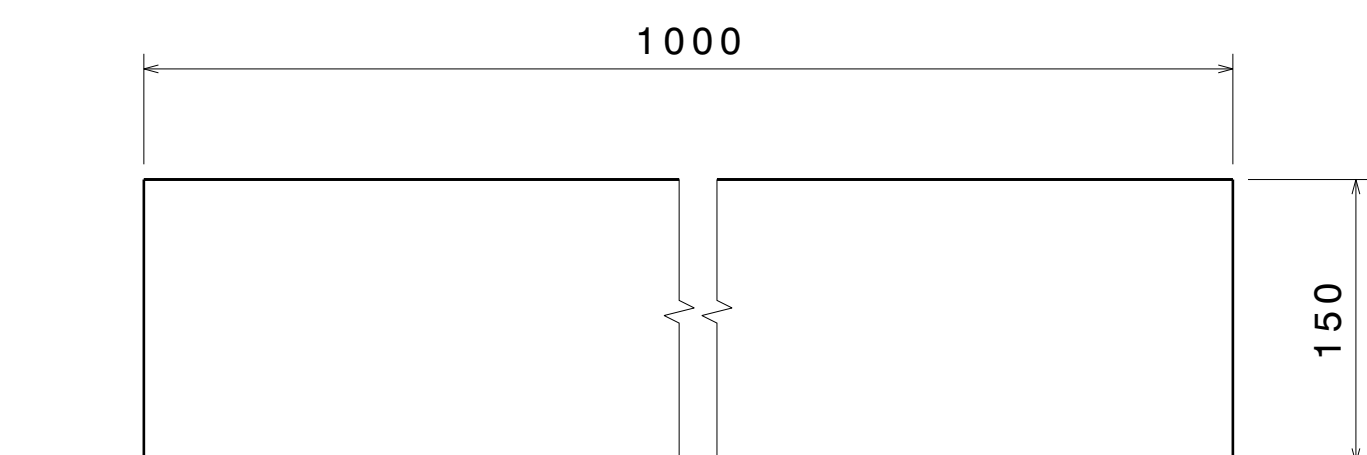

ITEM 16

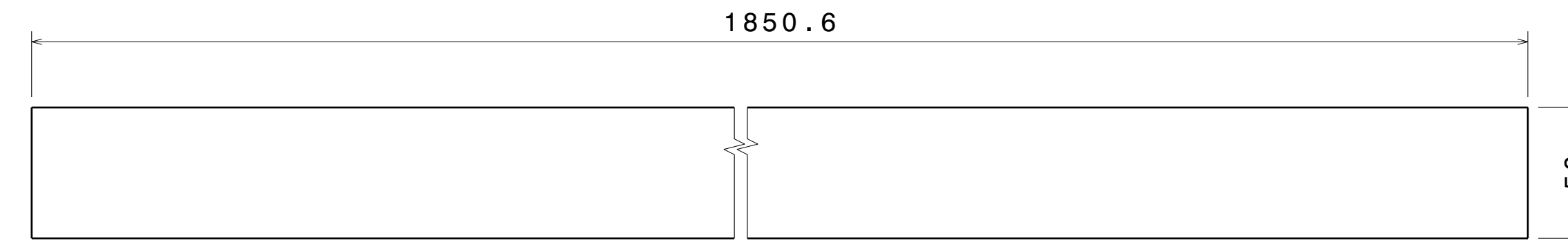

ITEM 9

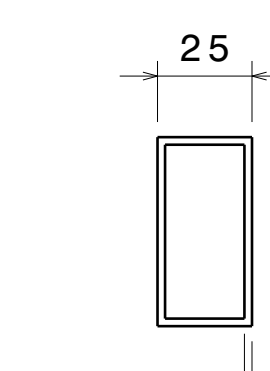

Right view[5]  
Scale: 1:2

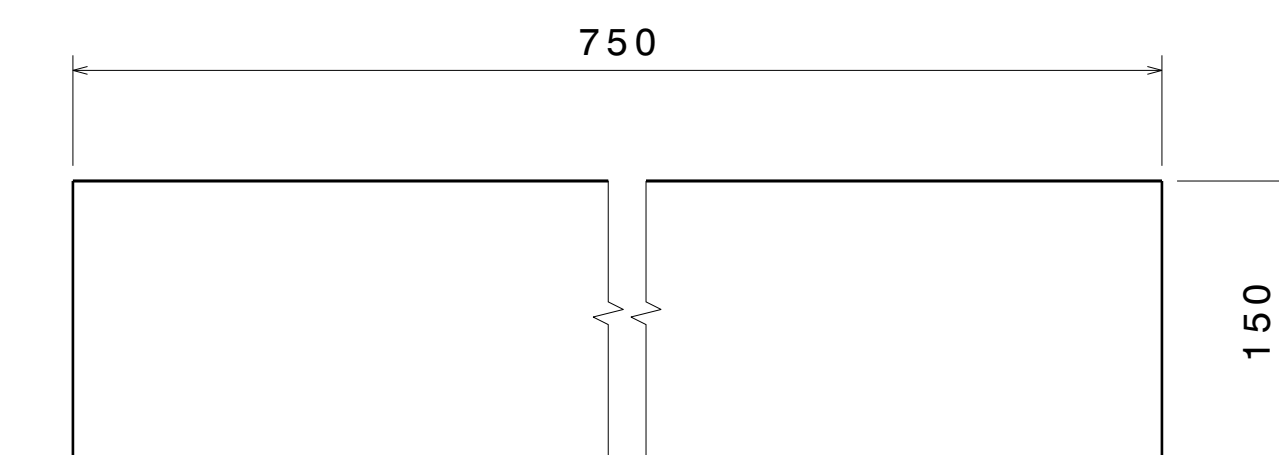

ITEM 17

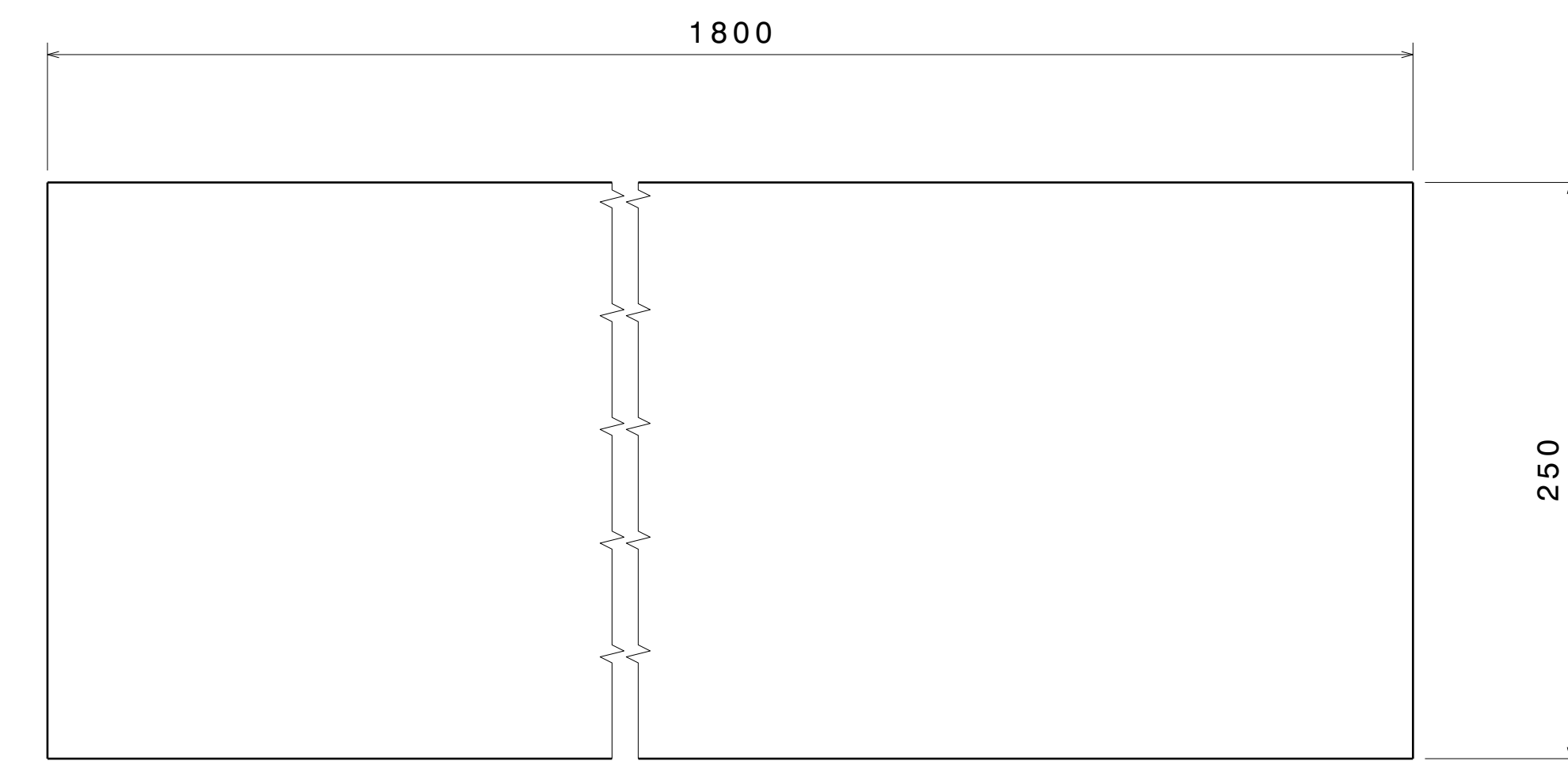

ITEM 2, PLANK

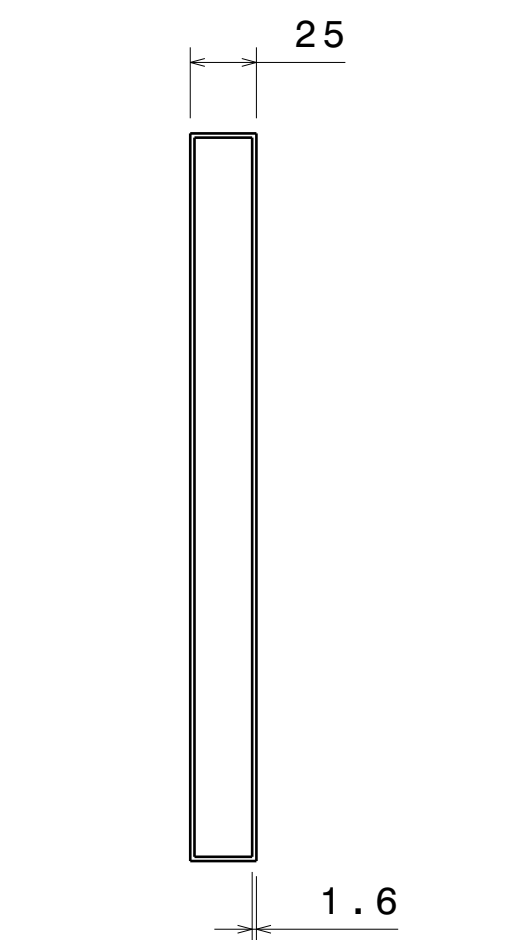

Right view[2]  
Scale: 7:20

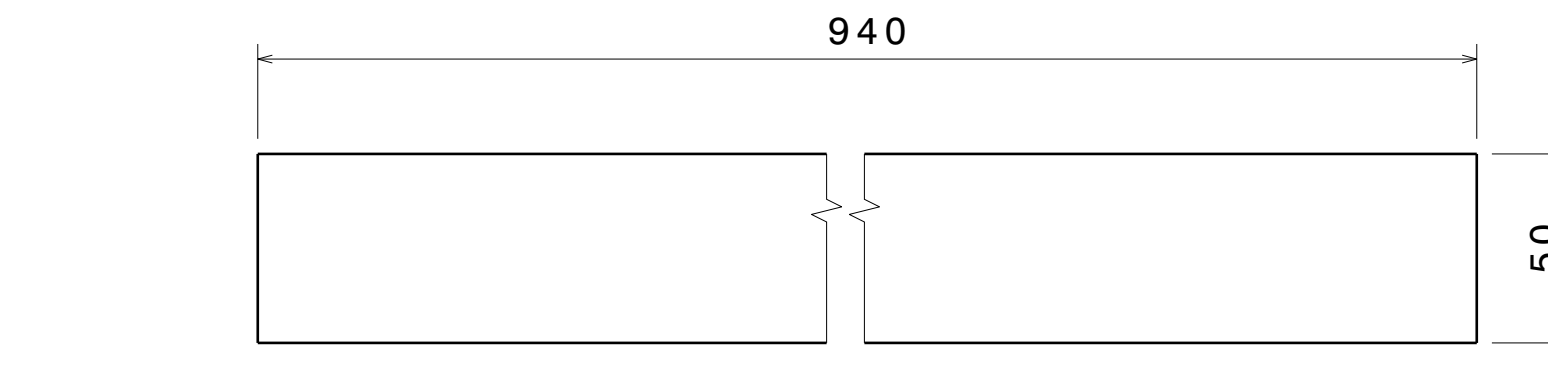

ITEM 10

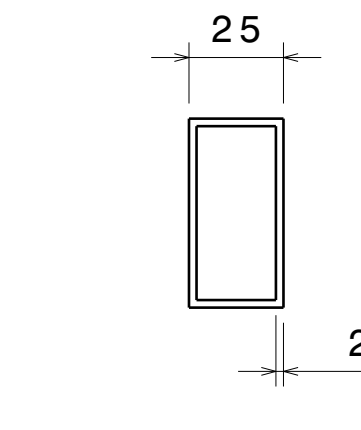

Right view[6]  
Scale: 1:2

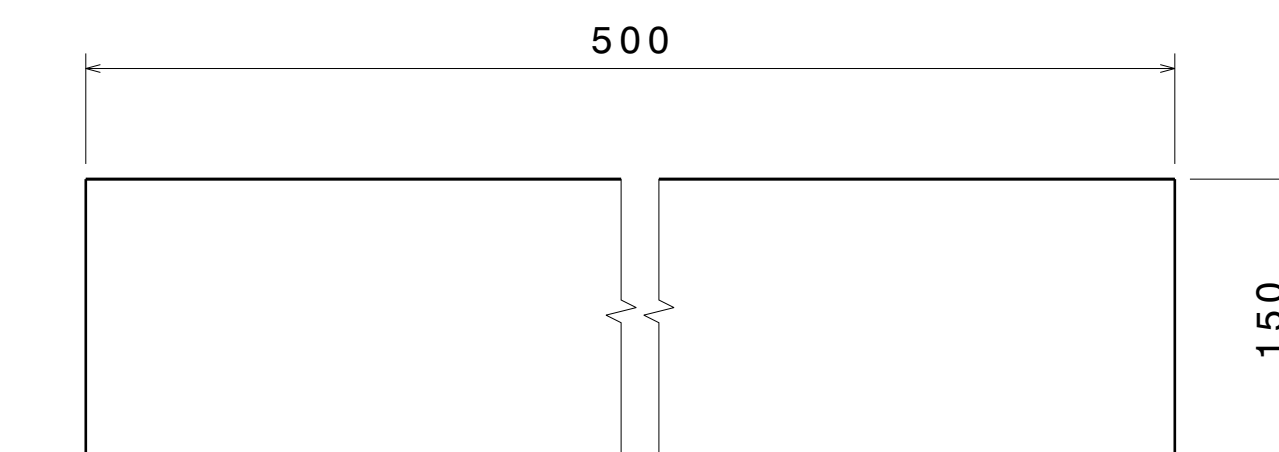

ITEM 18

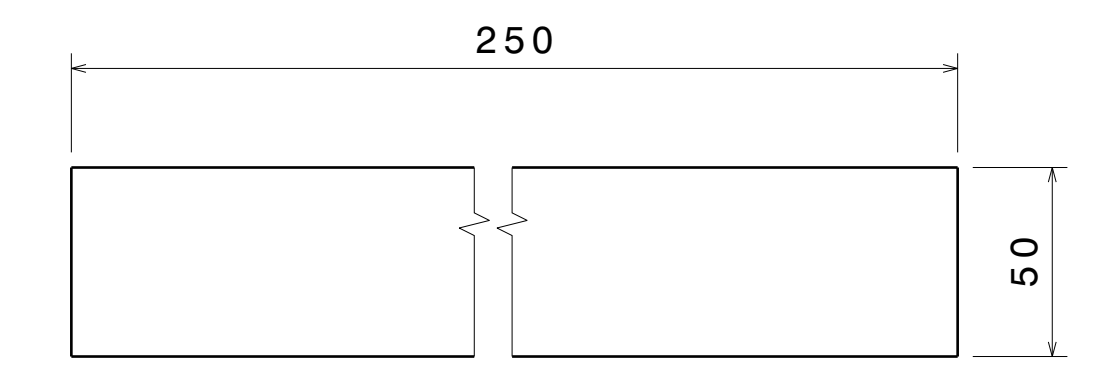

ITEM 21

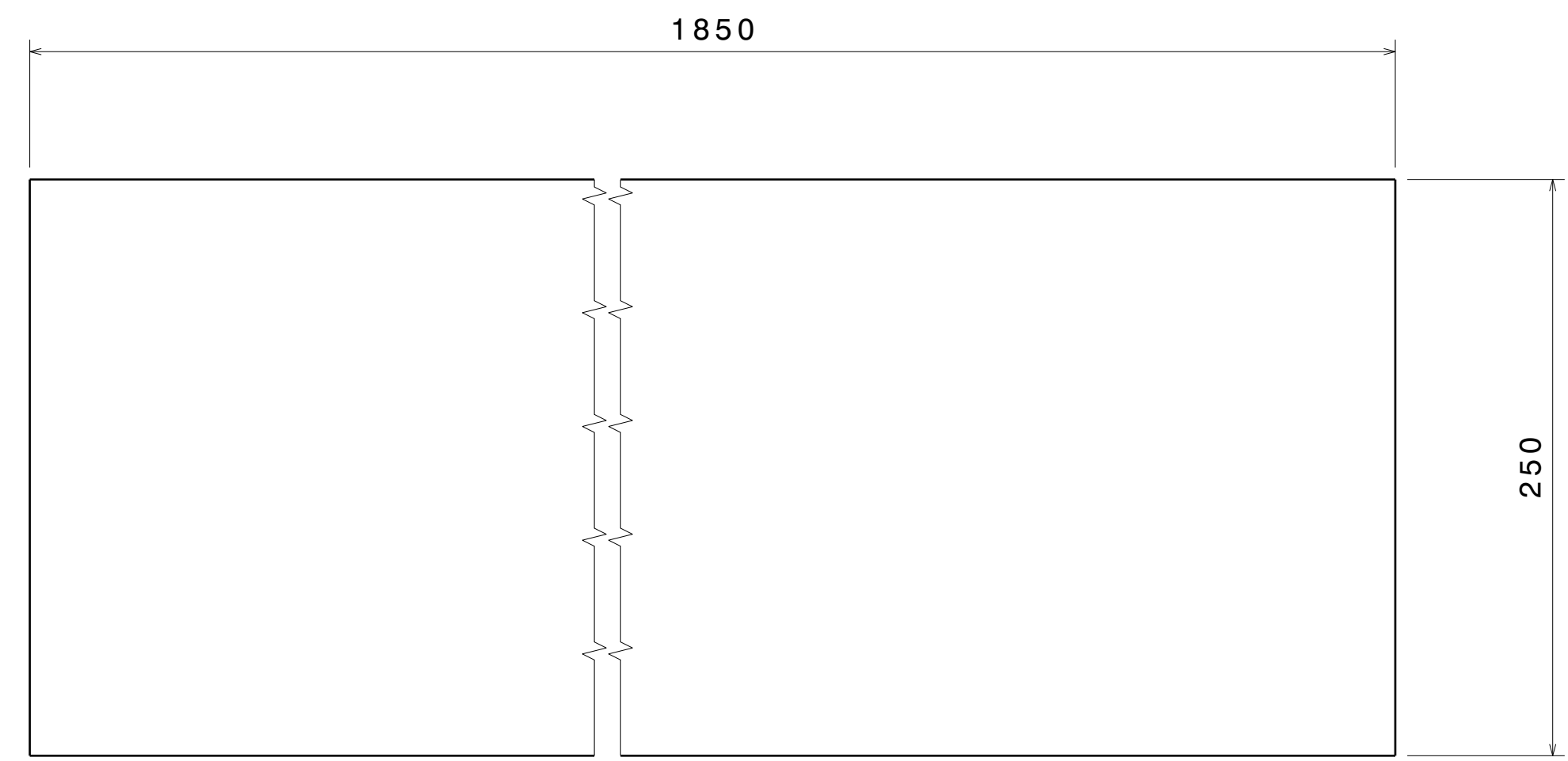

ITEM 3, PLANK

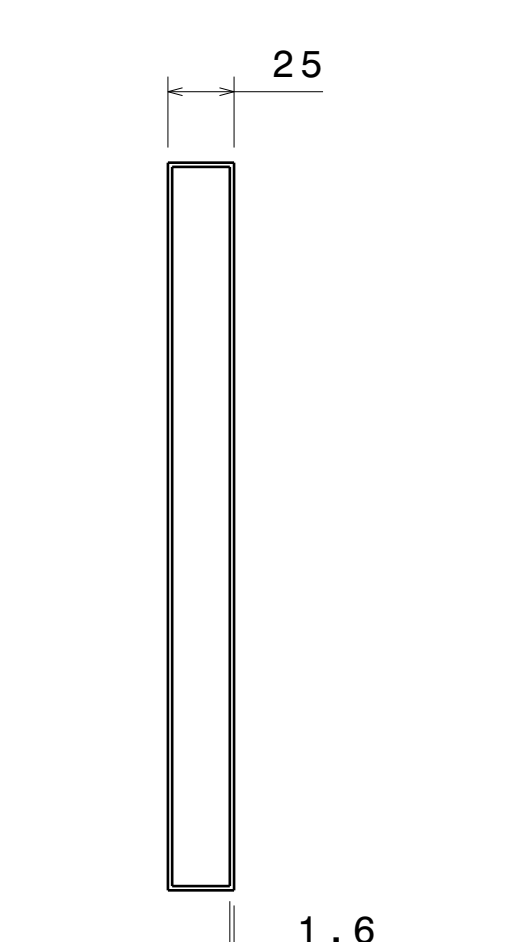

Right view[3]  
Scale: 7:20

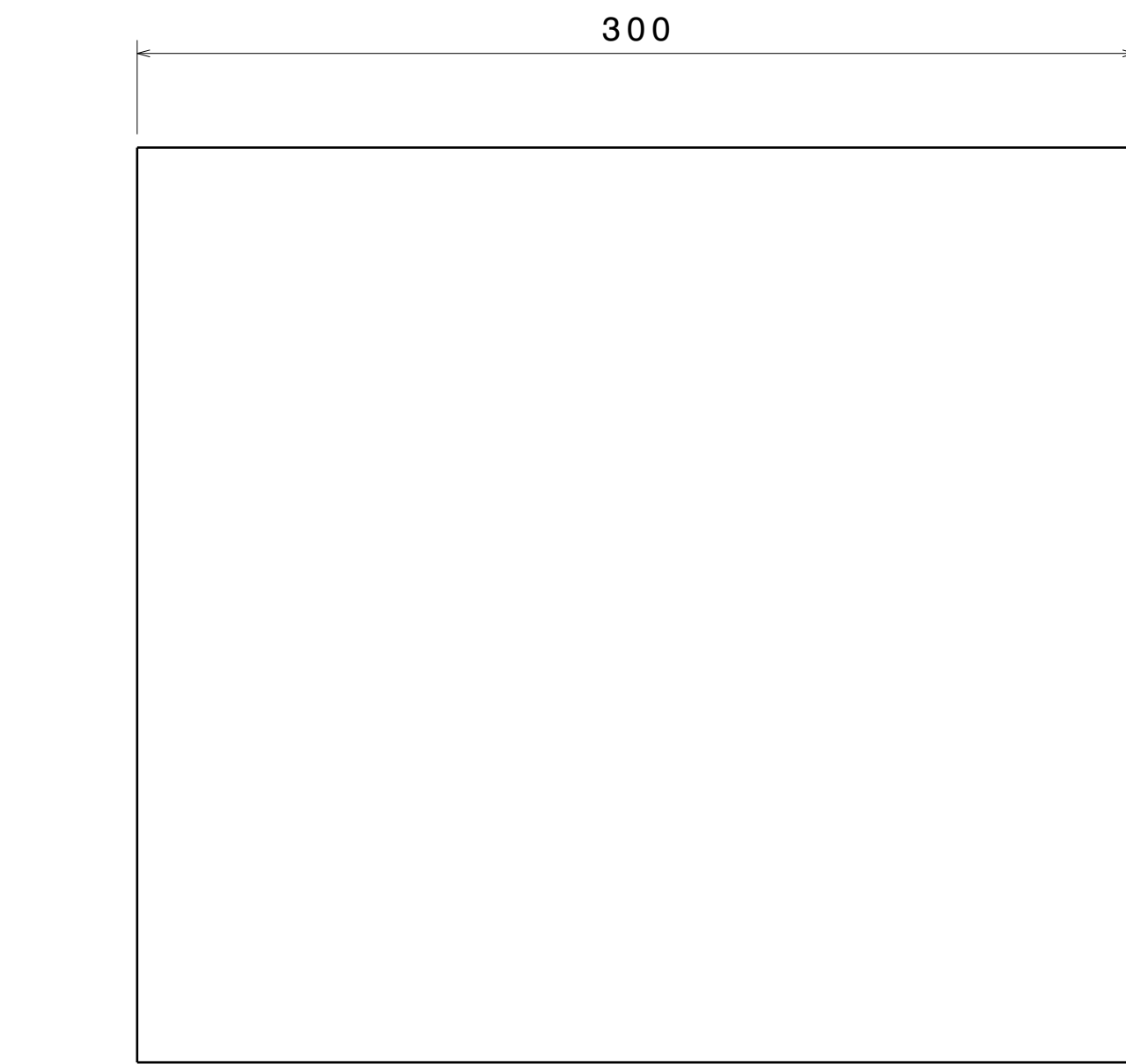

ITEM 11

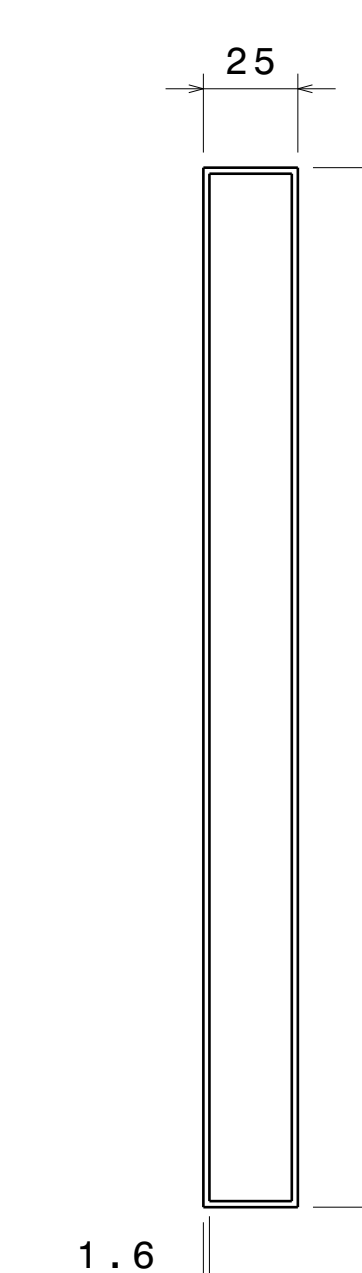

Right view  
Scale: 1:2

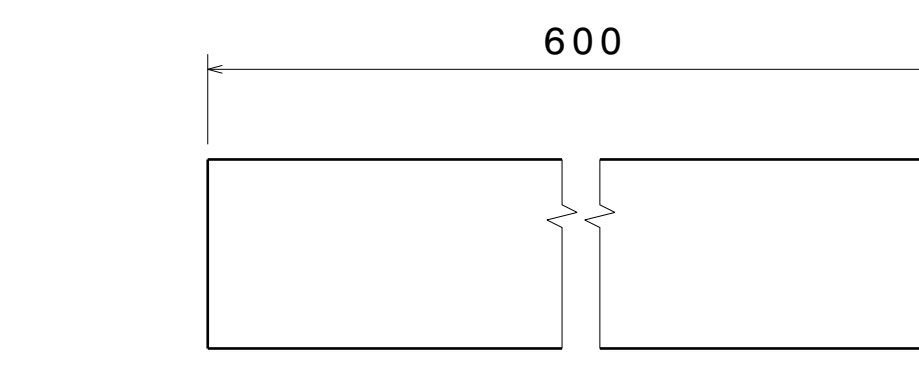

ITEM 19

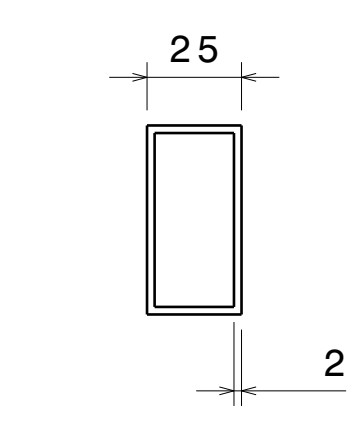

Right view  
Scale: 1:2

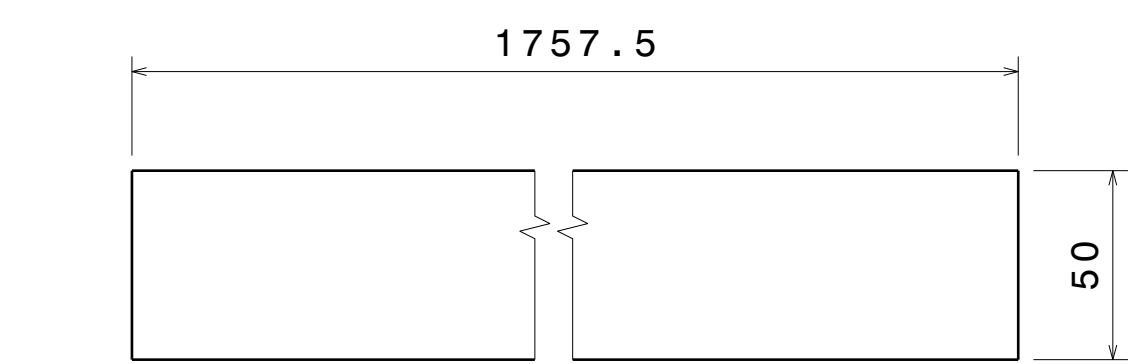

ITEM 22

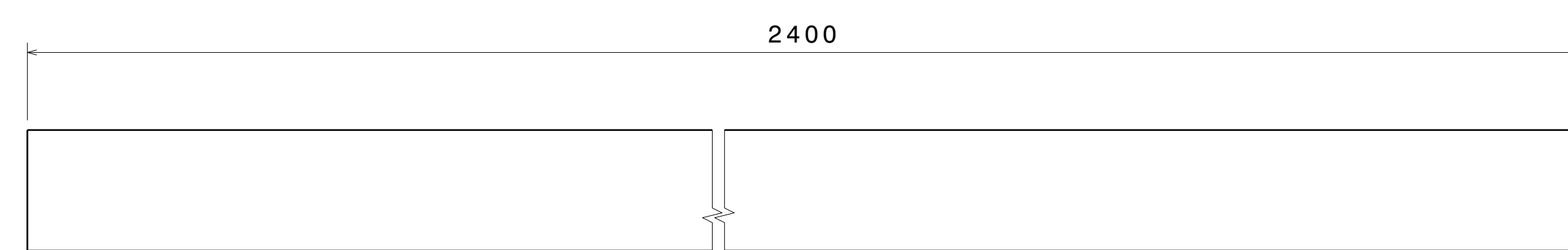

ITEM 4, SHS

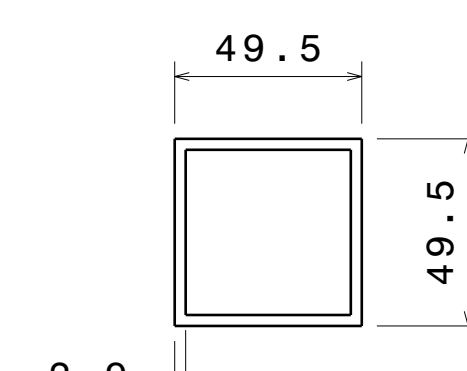

Right view  
Scale: 1:2

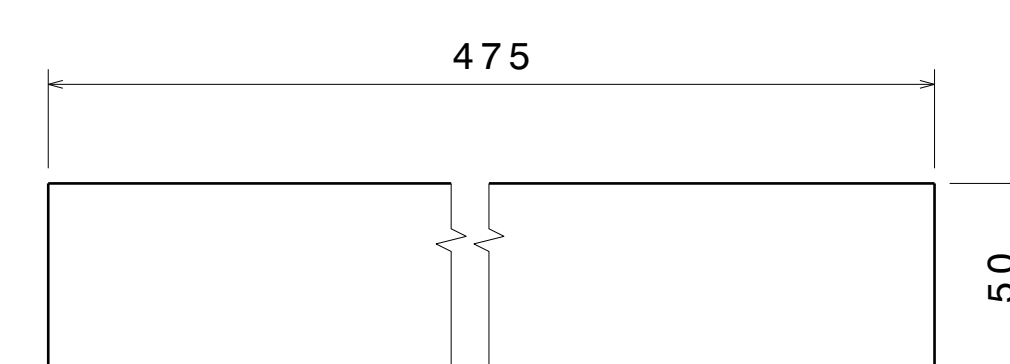

ITEM 20

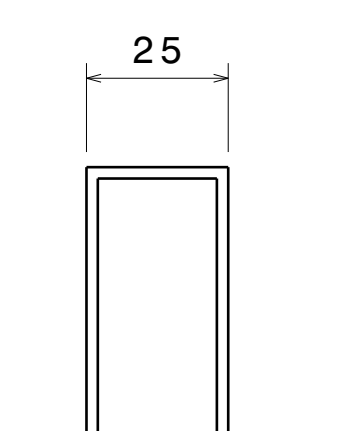

Right view  
TYPICAL FOR  
ITEM 20, 21, 22, 23

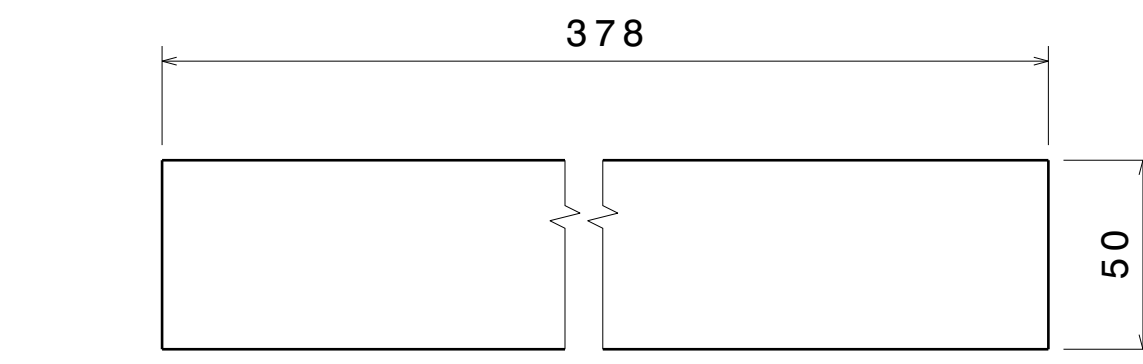

ITEM 23

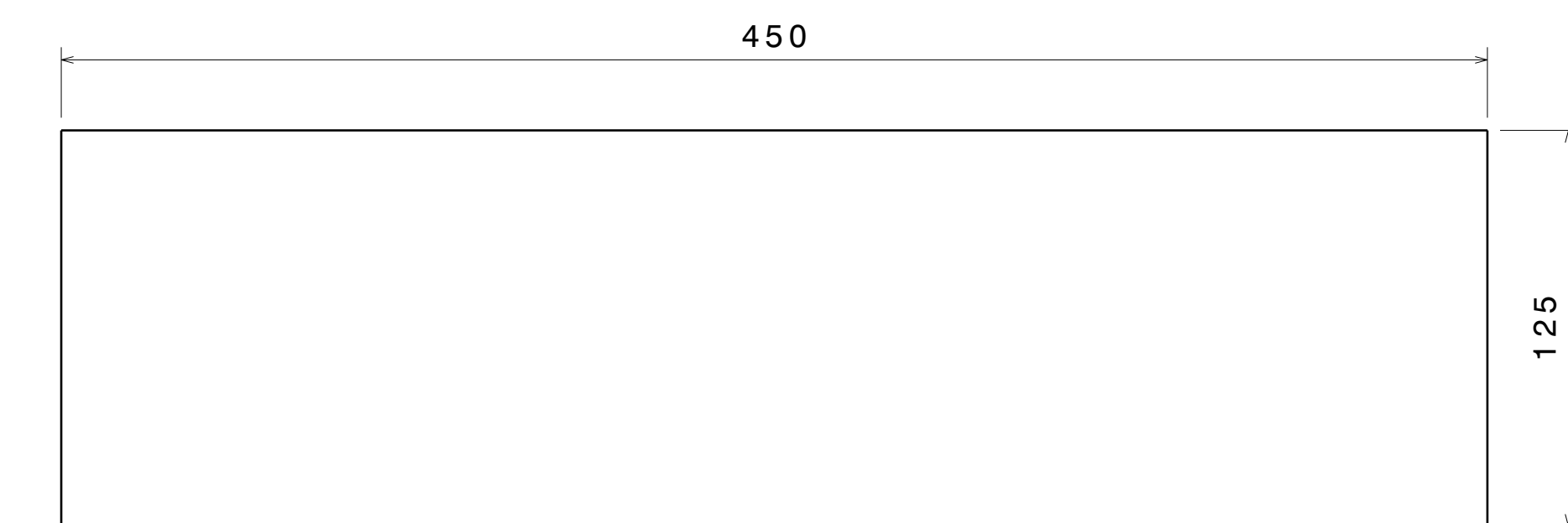

ITEM 5, PLANK



Right view  
Scale: 1:2

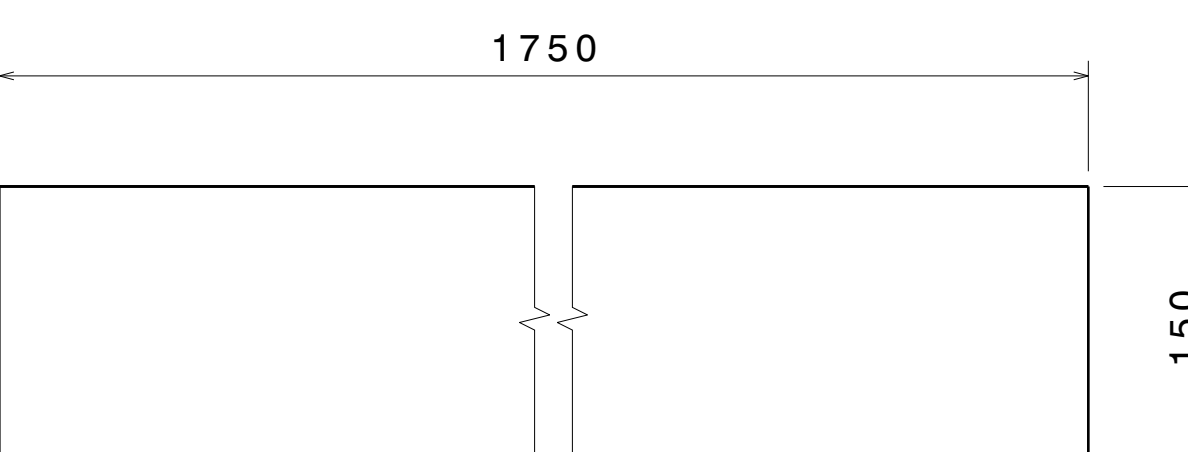

ITEM 13

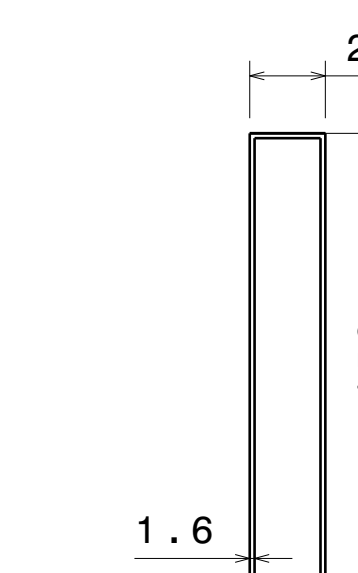

Right view  
TYPICAL FOR  
ITEM 13, 14, 15, 16, 17, 18

UNLESS OTHERWISE SPECIFIED DIMENSION ARE IN MM VIEWS: THIRD ANGLE PROJECTION

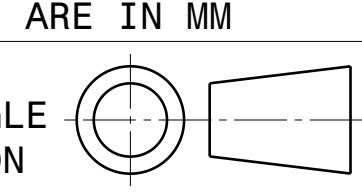

This drawing is our property. It can't be reproduced or communicated without our written agreement.

DRAWN BY		DATE		DRAWING TITLE	
SB		22NOV2020		NOV 20 04	
CHECKED BY	P2P Analysis & Solutions	DATE	22NOV2020	SIZE	DRAWING NUMBER
DESIGNED BY	P2P Analysis & Solutions	DATE	22NOV2020	A0	P2P NOV 20 04
SCALE	NONE	WEIGHT (kg)	XXX	REV	00
				SHEET 3 OF 3	



APL APOLLO TUBES LTD.