

REV	DATE	DESCRIPTION
00	25NOV2020	INITIAL REVISION

- NOTES:
- (⊥) ALL VERTICAL SUPPORTS ARE PERPENDICULAR.
 - FLATNESS OF .5MM IS APPLIED BY DEFAULT.
 - ⊘ WELD BEAD OF 2MM RADIUS IS FOLLOWED.
 - ▽ SURFACE FINISH MEDIUM TO SMOOTH IS USED.
 - ALL TUBES ARE AS PER APL APOLLO STANDARD. CHANGES MAY EFFECT THE LOAD CAPACITY.
 - ALL HORIZONTAL AND VERTICAL TUBES ARE PERPENDICULAR TO EACH OTHER WITH ±1 DEG.
 - FINE WELDING IS REQUIRED AS PER MENTIONED DETAILS AND FINISHING.
 - HIGHER CURRENT WELDING MAY AFFECT THE BRITTLNESS OF MATERIAL WHICH LATER MAY RAISE TO WEAKENING OF STRUCTURE.
 - FABRICATORS ARE ALLOWED TO USE FITTINGS/FRAMES/SUPPORTS AS NEEDED AND THE SAME MUST BE COMMUNICATED BACK TO ENGINEERING TEAM.
 - BOP COMPONENT WEIGHTS ARE FOR REFERENCE ONLY AND SUBJECTED TO CHANGE PER PURCHASED COMPONENTS.

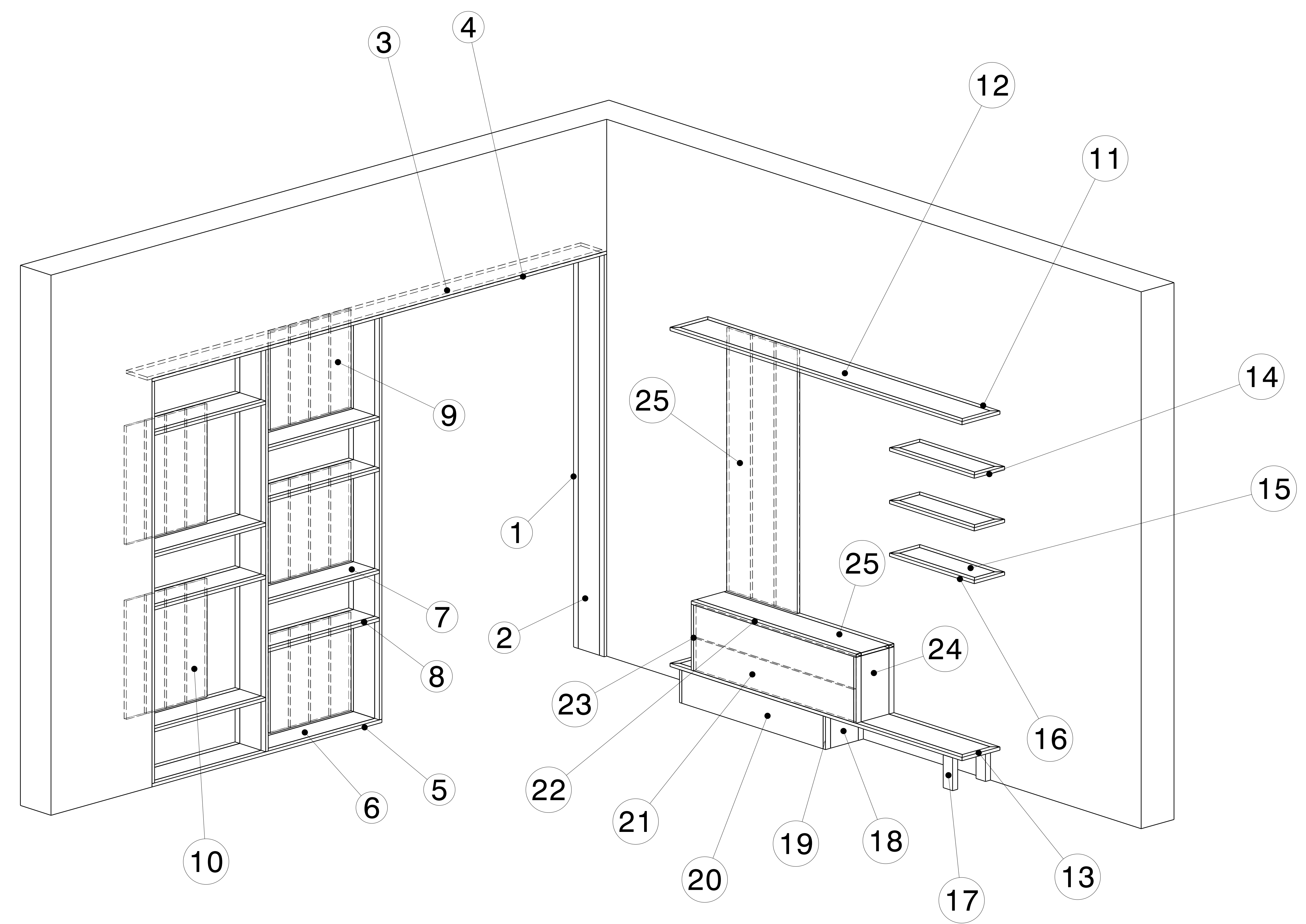

ISOMETRIC VIEW
SCALE: 1:10

ITEM NO.	PART NUMBER	DESCRIPTION	QTY.	Wt (Kg)/Each
25	RHS PLANK 13	275 X 25 X 2 X 1750	1	16.29
24	RHS PLANK 12	250 X 25 X 2 X 500	2	4.65
23	RHS FRAME 12	50 X 25 X 2 X 500	4	1.12
22	RHS FRAME 11	50 X 25 X 2 X 1750	2	3.91
21	RHS PLANK 11	250 X 25 X 2 X 1700	2	14.48
20	RHS PLANK 10	250 X 25 X 2 X 1500	2	12.78
19	RHS FRAME 10	50 X 25 X 2 X 250	4	0.56
18	RHS PLANK 9	275 X 25 X 2 X 250	2	2.33
17	RHS FRAME 9	100 X 50 X 3.6 X 250	2	2.02
16	RHS FRAME 8	50 X 25 X 2 X 900	6	1.9
15	RHS PLANK 8	200 X 25 X 2.0 X 800	3	5.56
14	RHS FRAME 7	50 X 25 X 2 X 300	6	0.56
13	RHS FRAME 6	50 X 25 X 2 X 375	4	0.73
12	RHS PLANK 7	275 X 25 X 2.0 X 3000	2	27.92
11	RHS FRAME 5	50 X 25 X 2 X 3100	4	6.81
10	RHS PLANK 6	200 X 25 X 2.0 X 900	8	6.25
9	RHS PLANK 5	200 X 25 X 2.0 X 750	12	5.21
8	RHS FRAME 4	50 X 25 X 2.6 X 1100	16	3.14
7	RHS PLANK 4	225 X 25 X 2.0 X 1100	8	8.51
6	RHS PLANK 3	225 X 25 X 2.0 X 2250	1	17.4
5	RHS FRAME 3	50 X 25 X 2.6 X 2275	2	6.49
4	RHS FRAME 2	50 X 25 X 2.6 X 4500	2	12.84
3	RHS PLANK 2	225 X 25 X 2.0 X 4500	1	34.8
2	RHS PLANK 1	225 X 25 X 2.0 X 3050	4	23.59
1	RHS FRAME 1	50 X 25 X 2.6 X 3050	8	8.7

This drawing is our property. It can't be reproduced or communicated without our written agreement.

APL APOLLO TUBES LTD.

DRAWING TITLE: NOV 20_10-PARTITION AND SHELF

CHECKED BY: VM, DATE: 25NOV2020

DESIGNED BY: P2P Analysis & Solutions, DATE: 25NOV2020

SCALE: A0, WEIGHT(kg): As Indicated, SHEET 1 OF 3

UNLESS OTHERWISE SPECIFIED DIMENSION ARE IN MM VIEWS: THIRD ANGLE PROJECTION

REV	DATE	DESCRIPTION
00	25NOV2020	INITIAL REVISION

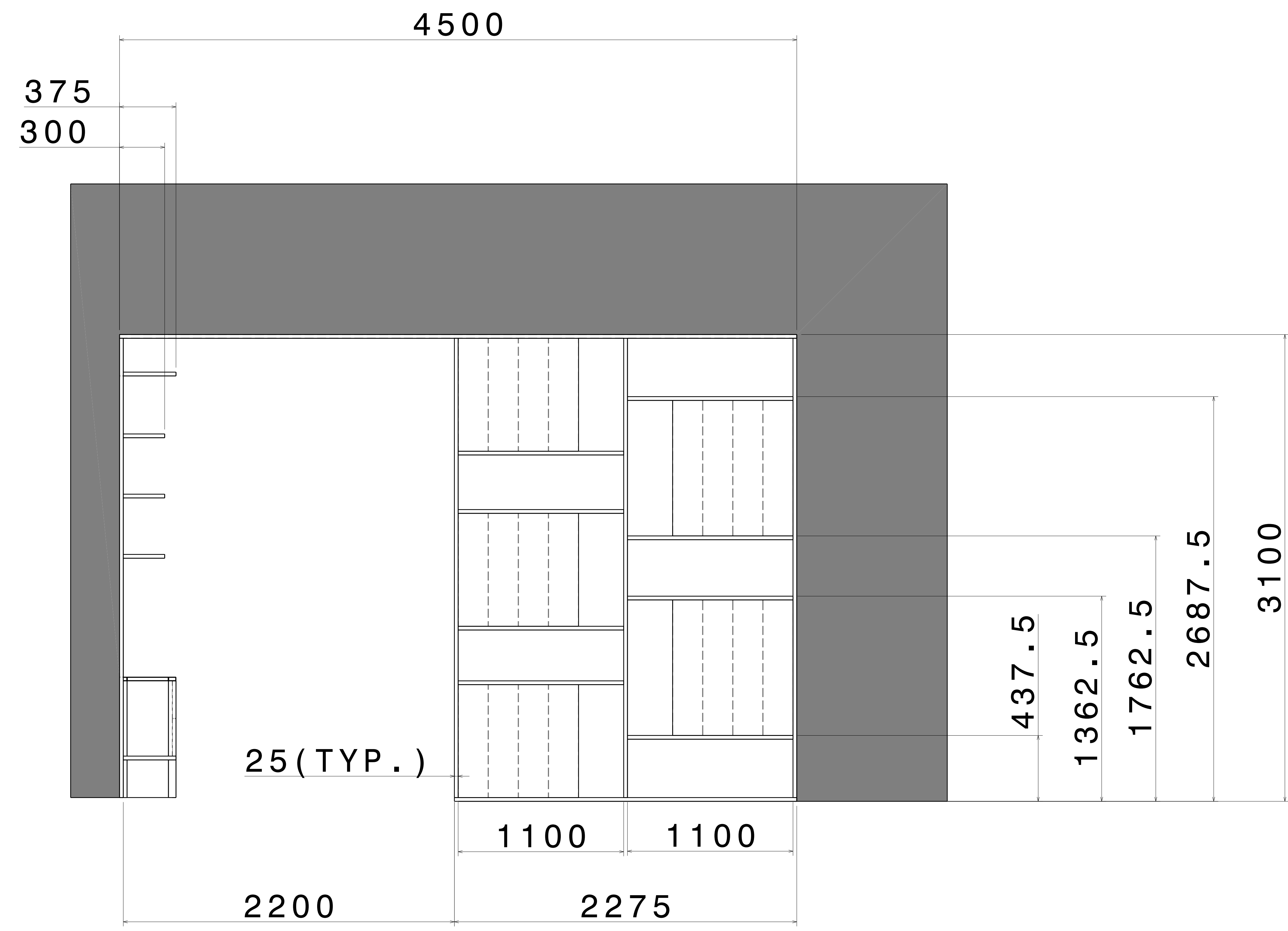

FRONT VIEW
SCALE: 1:15

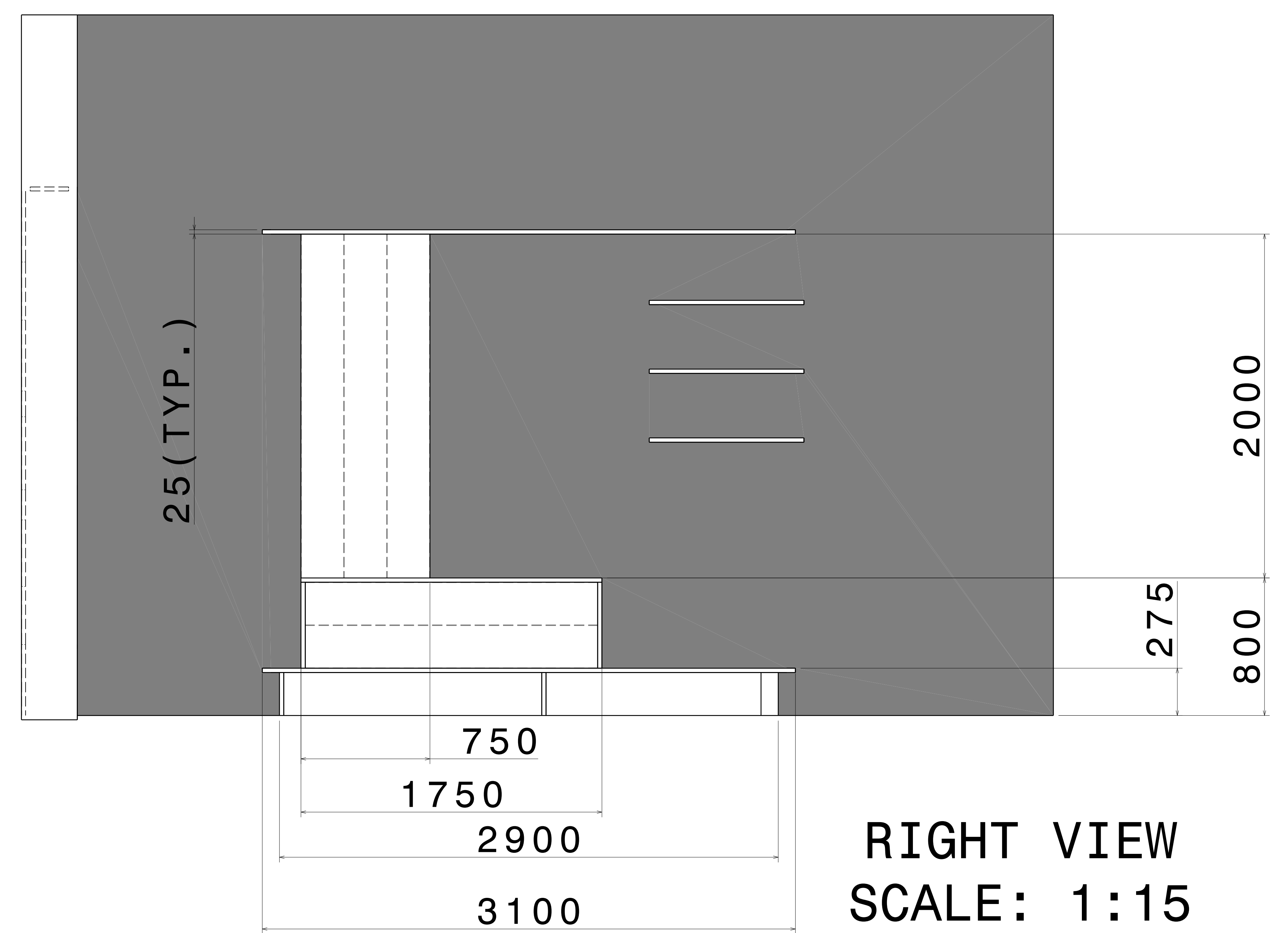

RIGHT VIEW
SCALE: 1:15

UNLESS OTHERWISE SPECIFIED DIMENSION ARE IN MM
VIEWS: THIRD ANGLE PROJECTION

This drawing is our property. It can't be reproduced or communicated without our written agreement.		APL APOLLO TUBES LTD.	
DRAWN BY SB		DATE 25NOV2020	
CHECKED BY P2P Analysis & Solutions		DATE 25NOV2020	
DESIGNED BY P2P Analysis & Solutions		DATE 25NOV2020	
DRAWING TITLE NOV 20 10-PARTITION AND SHELF		REV 00	
SIZE A0		DRAWING NUMBER P2P NOV 20 10-PARTITION AND SHELF	
SCALE NONE		WEIGHT(kg) XXX	
SHEET 2 OF 3			

REV	DATE	DESCRIPTION
00	25NOV2020	INITIAL REVISION

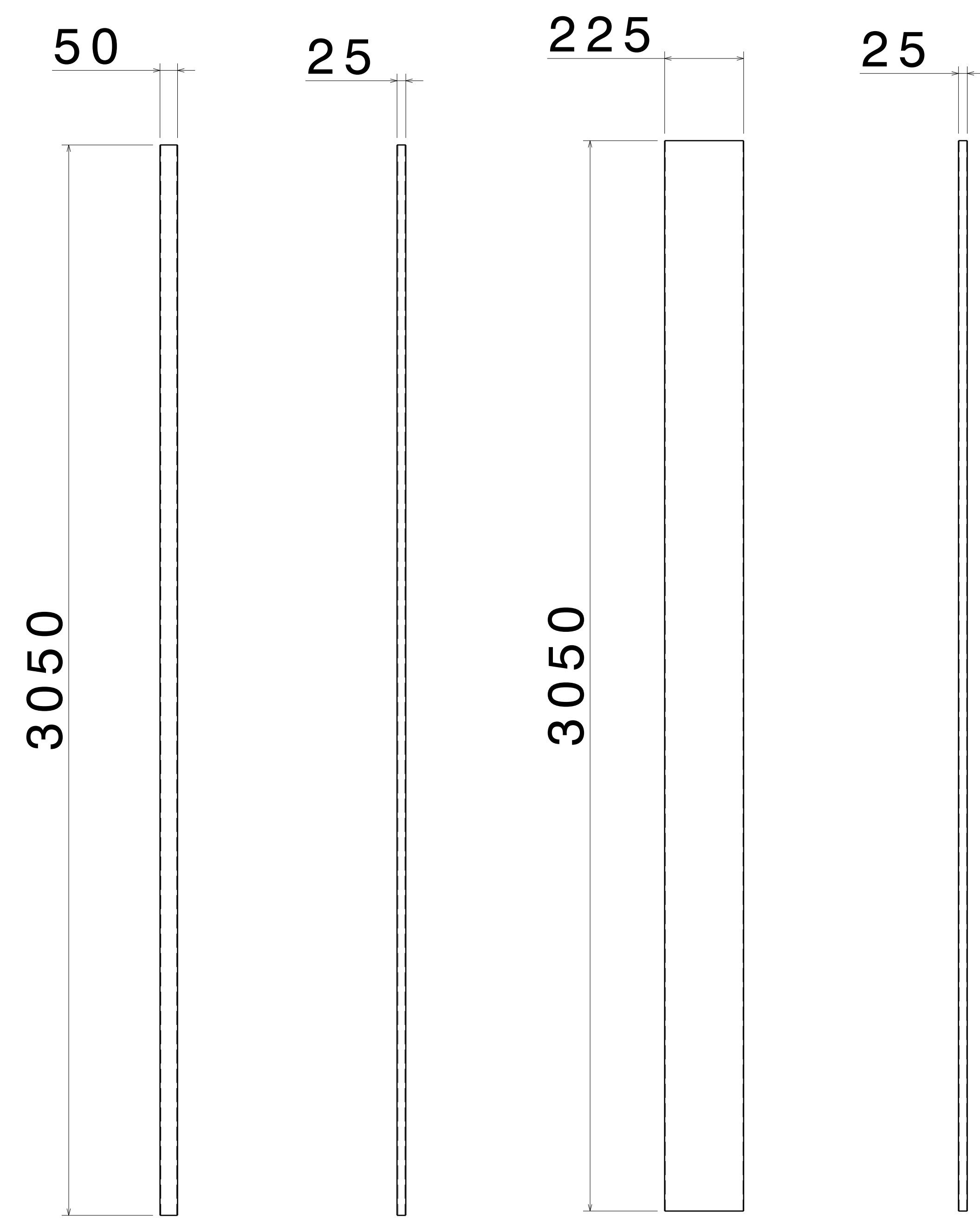

FRONT VIEW RIGHT VIEW
SCALE: 1:10 SCALE: 1:10
ITEM 1, RHS FRAME 1
THICKNESS - 2.6MM

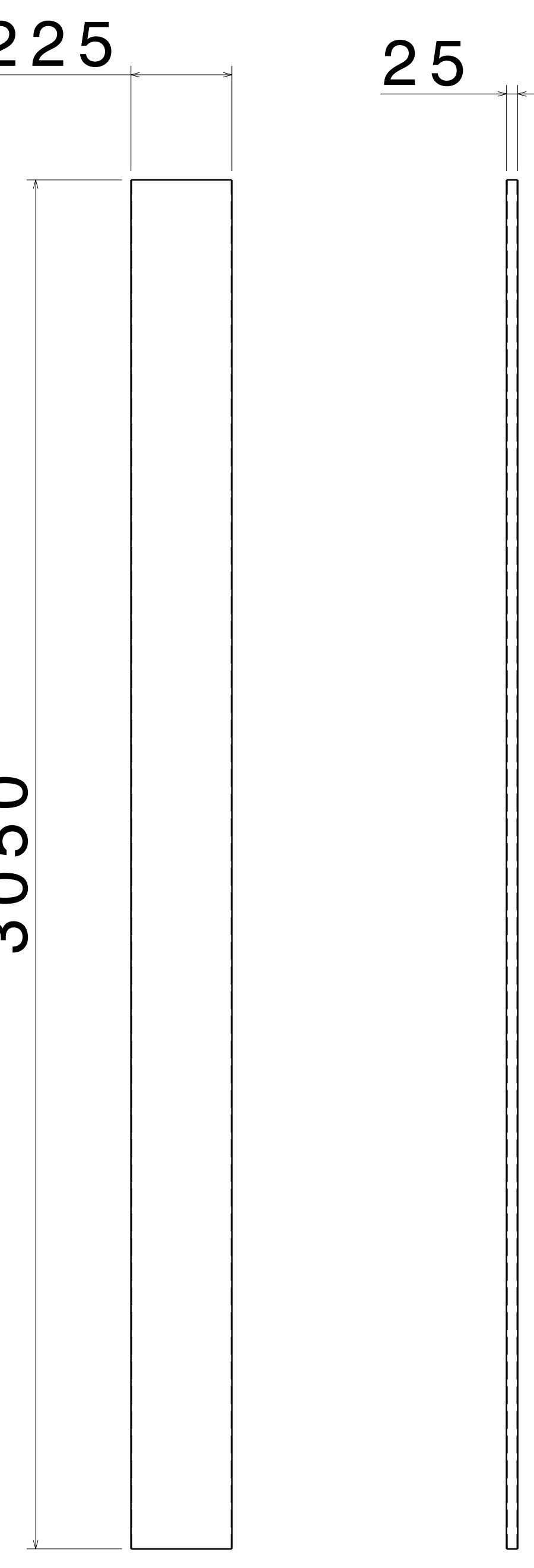

FRONT VIEW RIGHT VIEW
SCALE: 1:10 SCALE: 1:10
ITEM 2, RHS PLANK 1
THICKNESS - 2.0MM

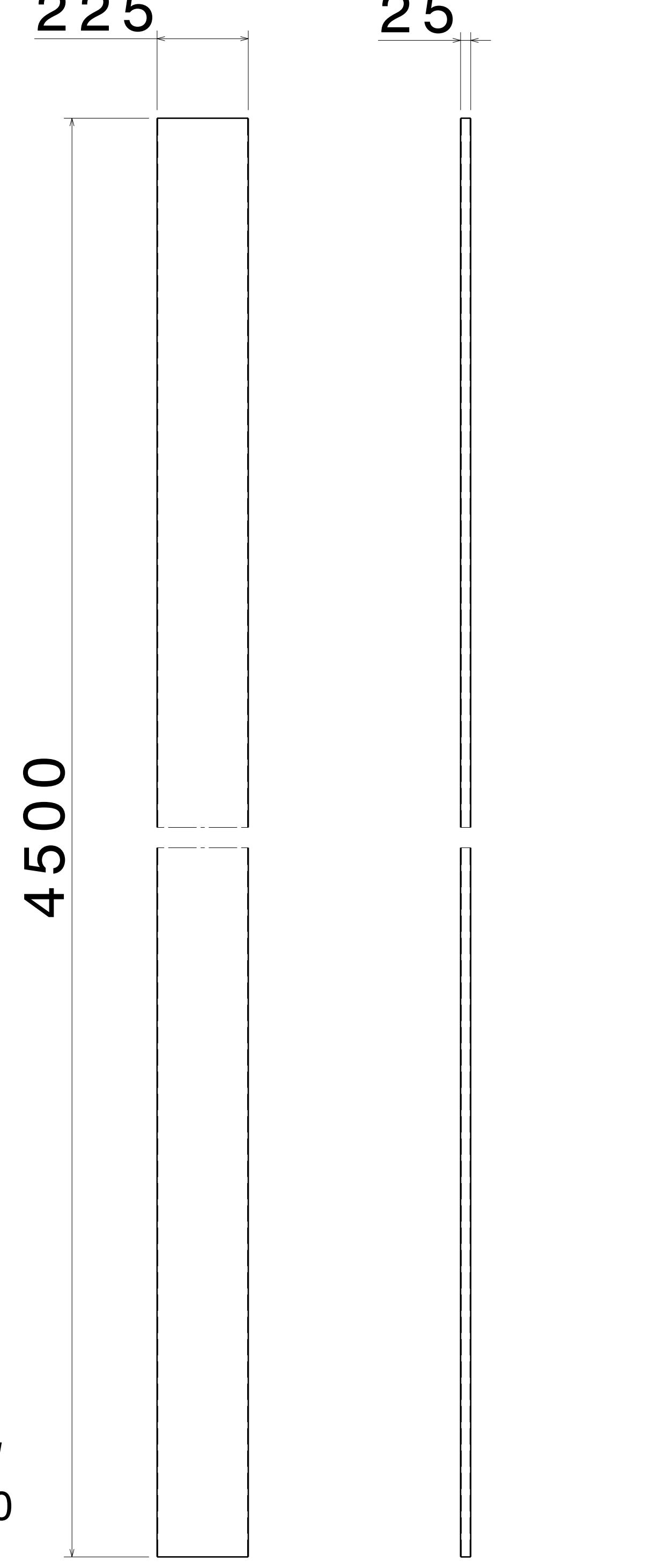

FRONT VIEW RIGHT VIEW
SCALE: 1:10 SCALE: 1:10
ITEM 3, RHS PLANK 2
THICKNESS - 2.0MM

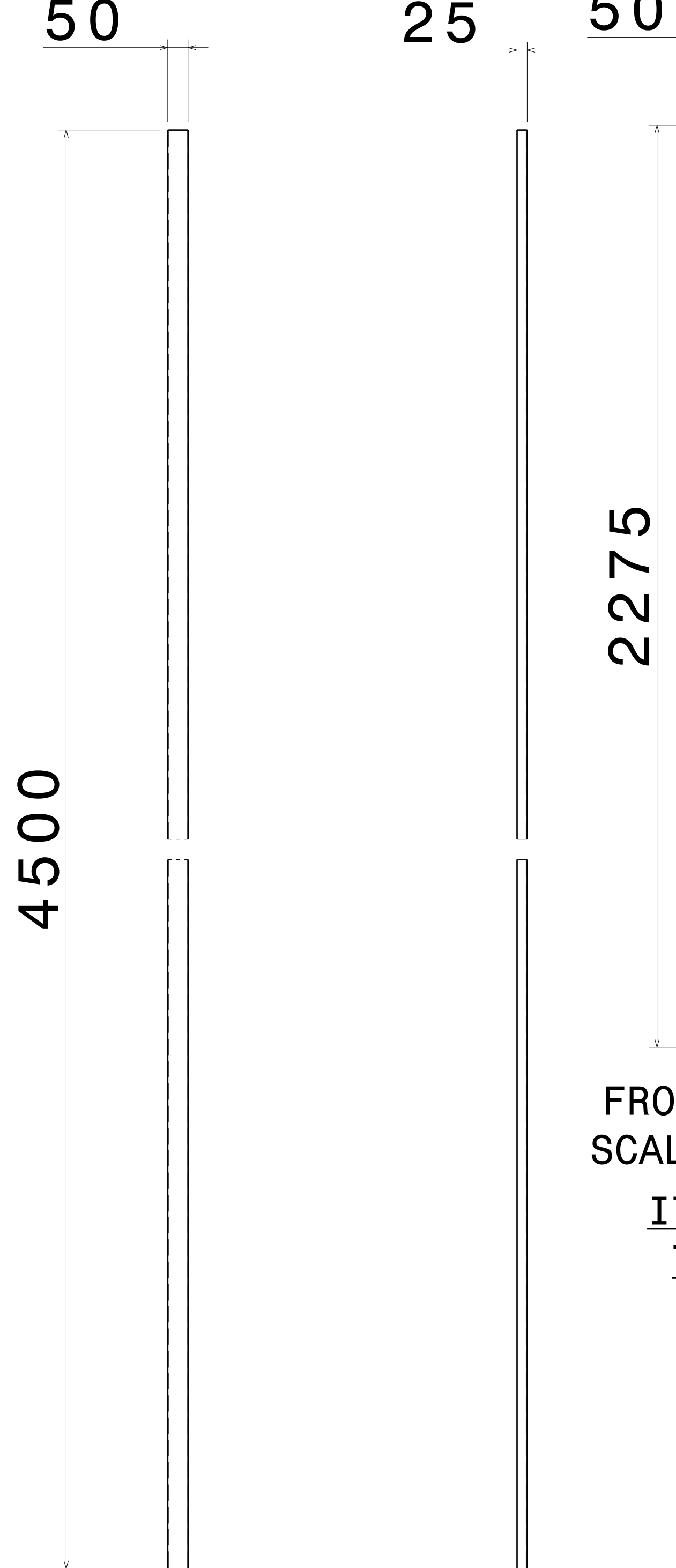

FRONT VIEW RIGHT VIEW
SCALE: 1:10 SCALE: 1:10
ITEM 4, RHS FRAME 2
THICKNESS - 2.6MM

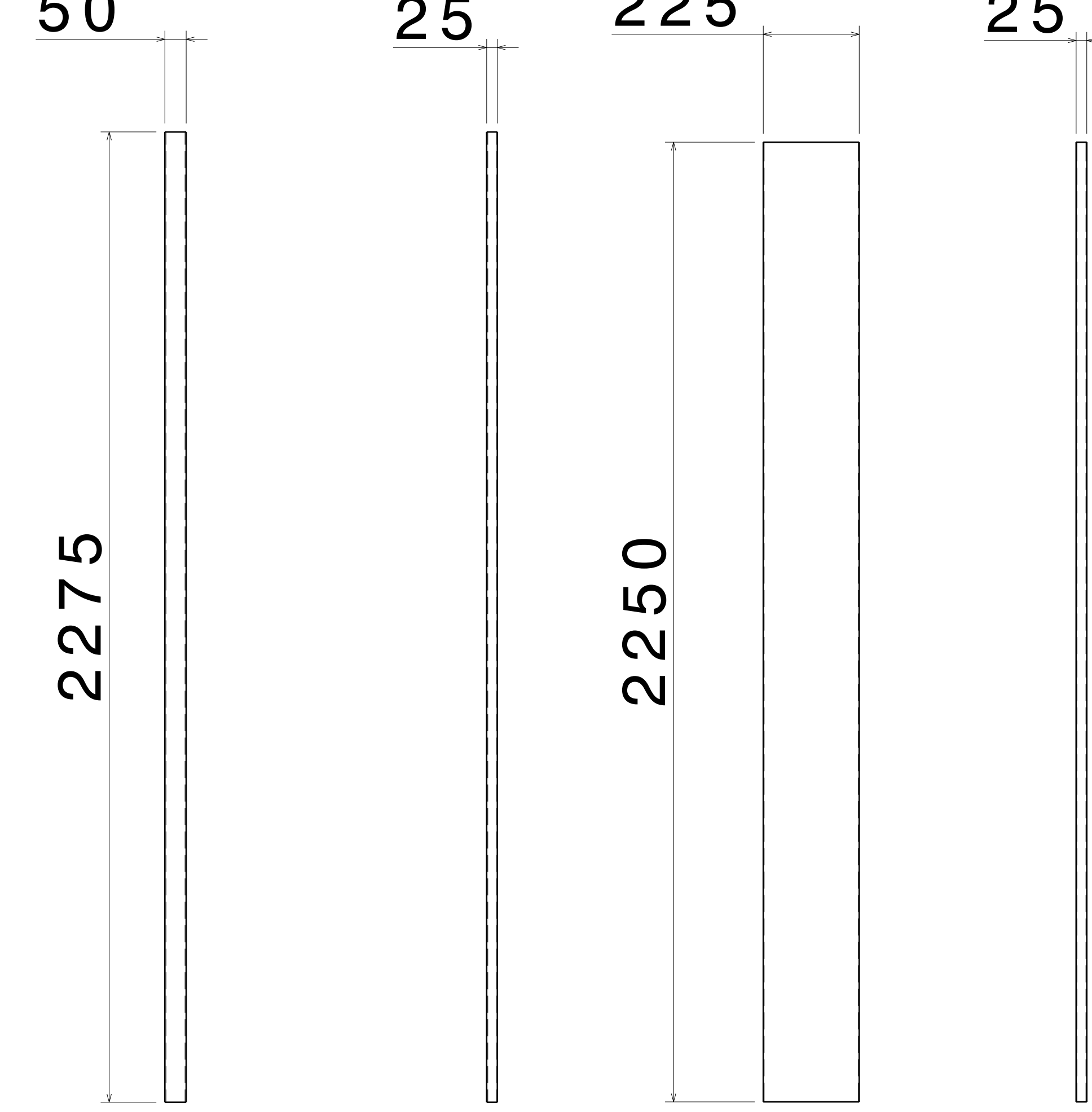

FRONT VIEW RIGHT VIEW FRONT VIEW RIGHT VIEW
SCALE: 1:10 SCALE: 1:10 SCALE: 1:10 SCALE: 1:10
ITEM 5, RHS FRAME 3 THICKNESS - 2.6MM
ITEM 6, RHS PLANK 3 THICKNESS - 2.0MM

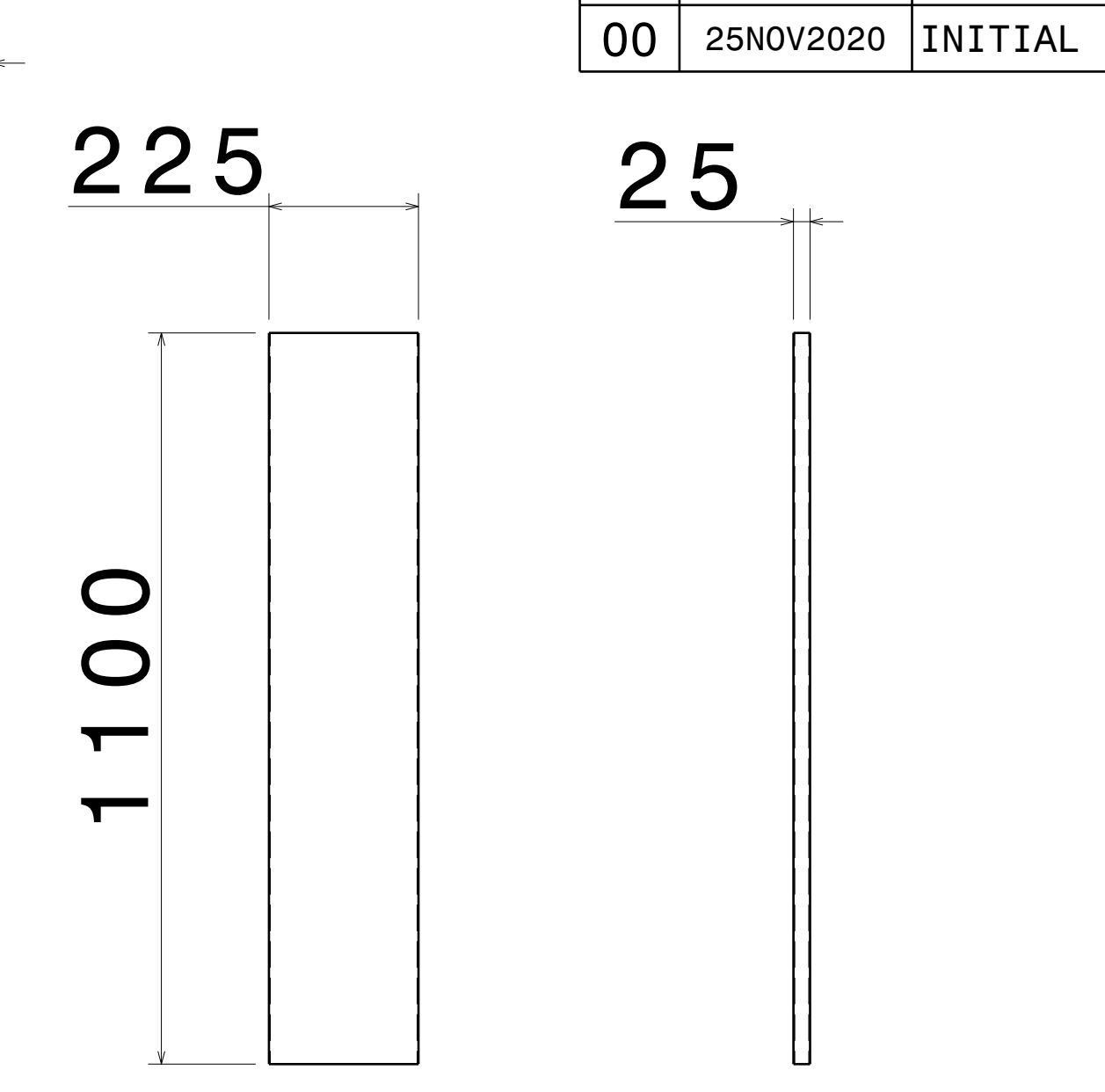

FRONT VIEW RIGHT VIEW
SCALE: 1:10 SCALE: 1:10
ITEM 7, RHS PLANK 4
THICKNESS - 2.0MM

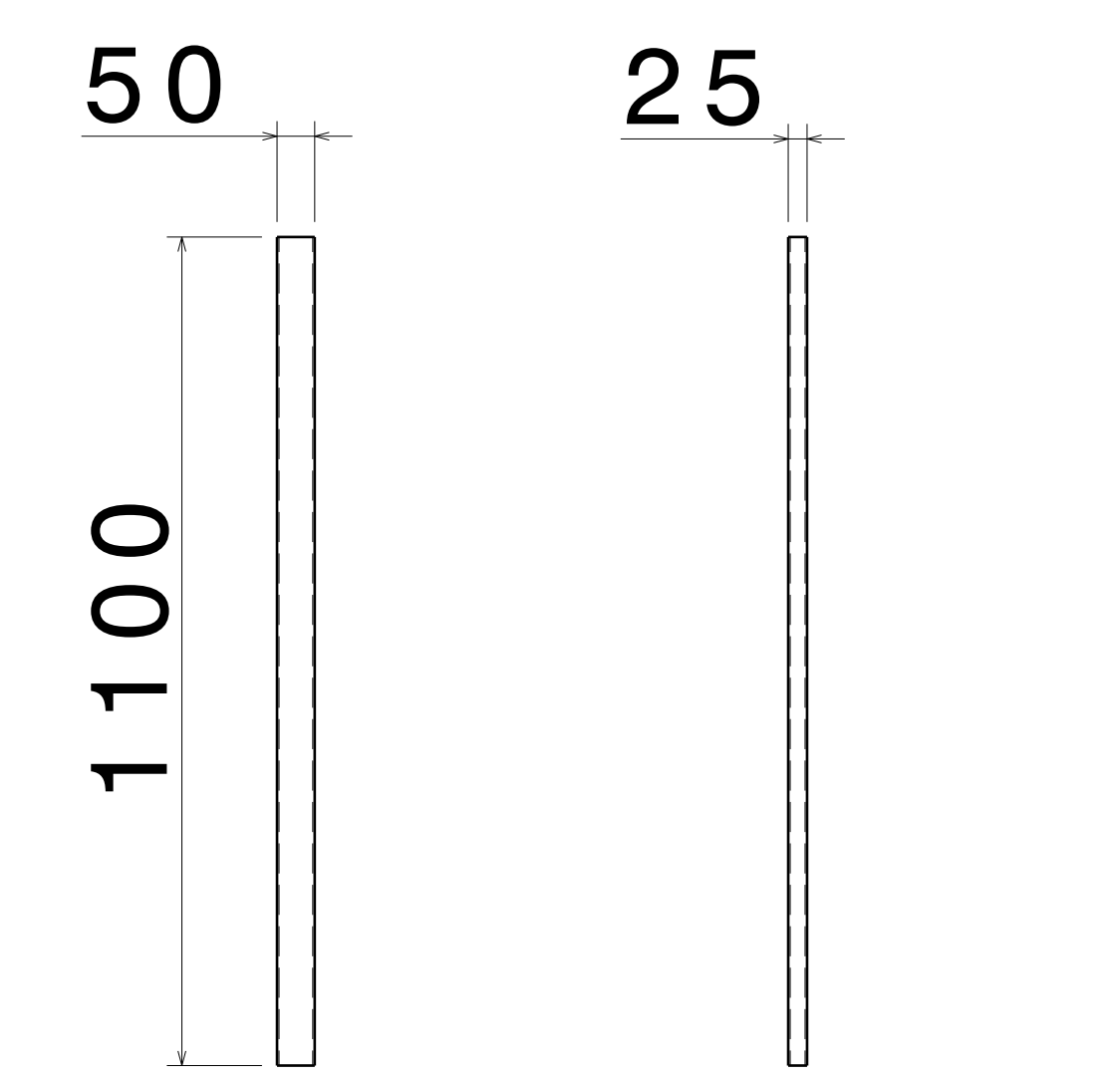

FRONT VIEW RIGHT VIEW
SCALE: 1:10 SCALE: 1:10
ITEM 8, RHS FRAME 4
THICKNESS - 2.6MM

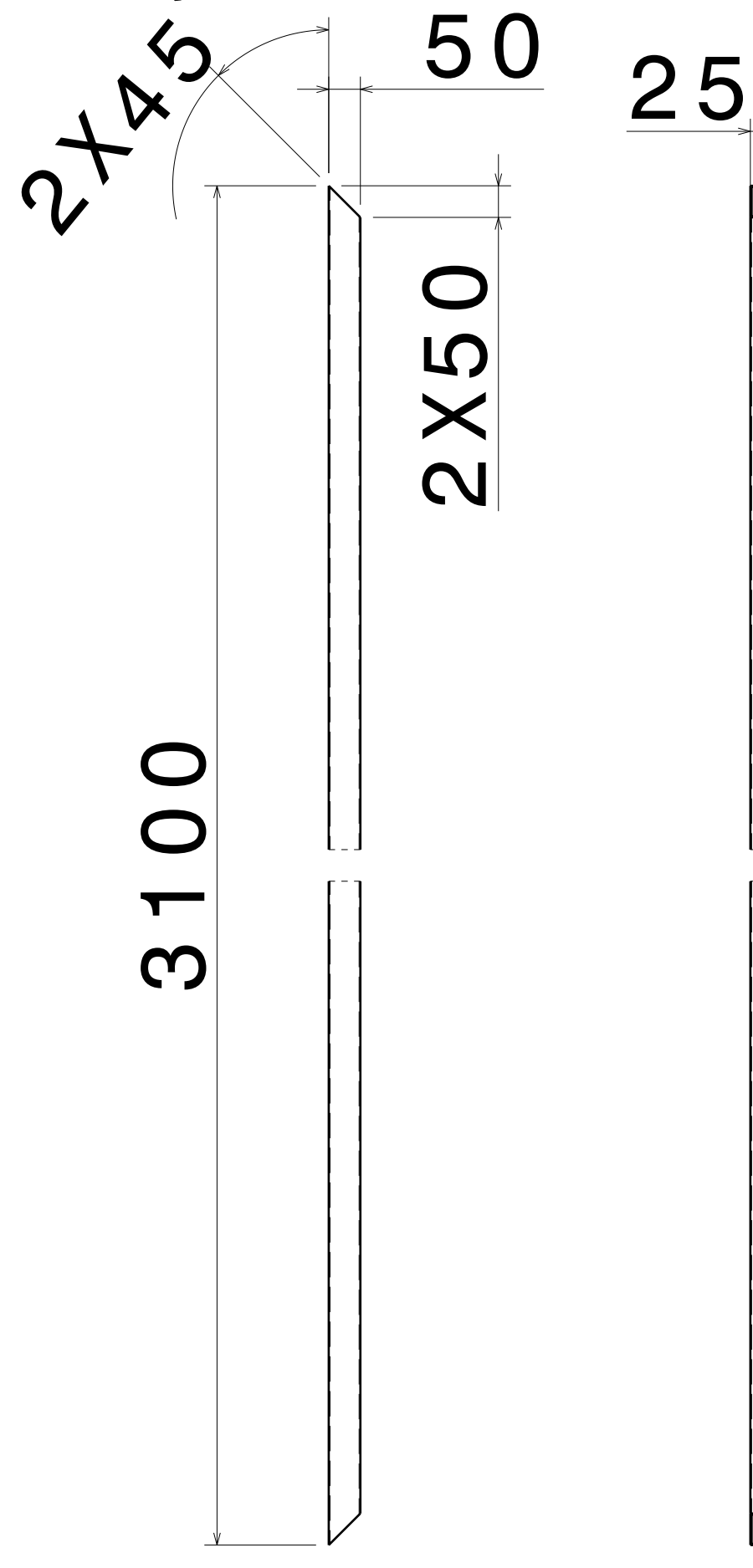

FRONT VIEW RIGHT VIEW
SCALE: 1:10 SCALE: 1:10
ITEM 11, RHS FRAME 5
THICKNESS - 2.0MM

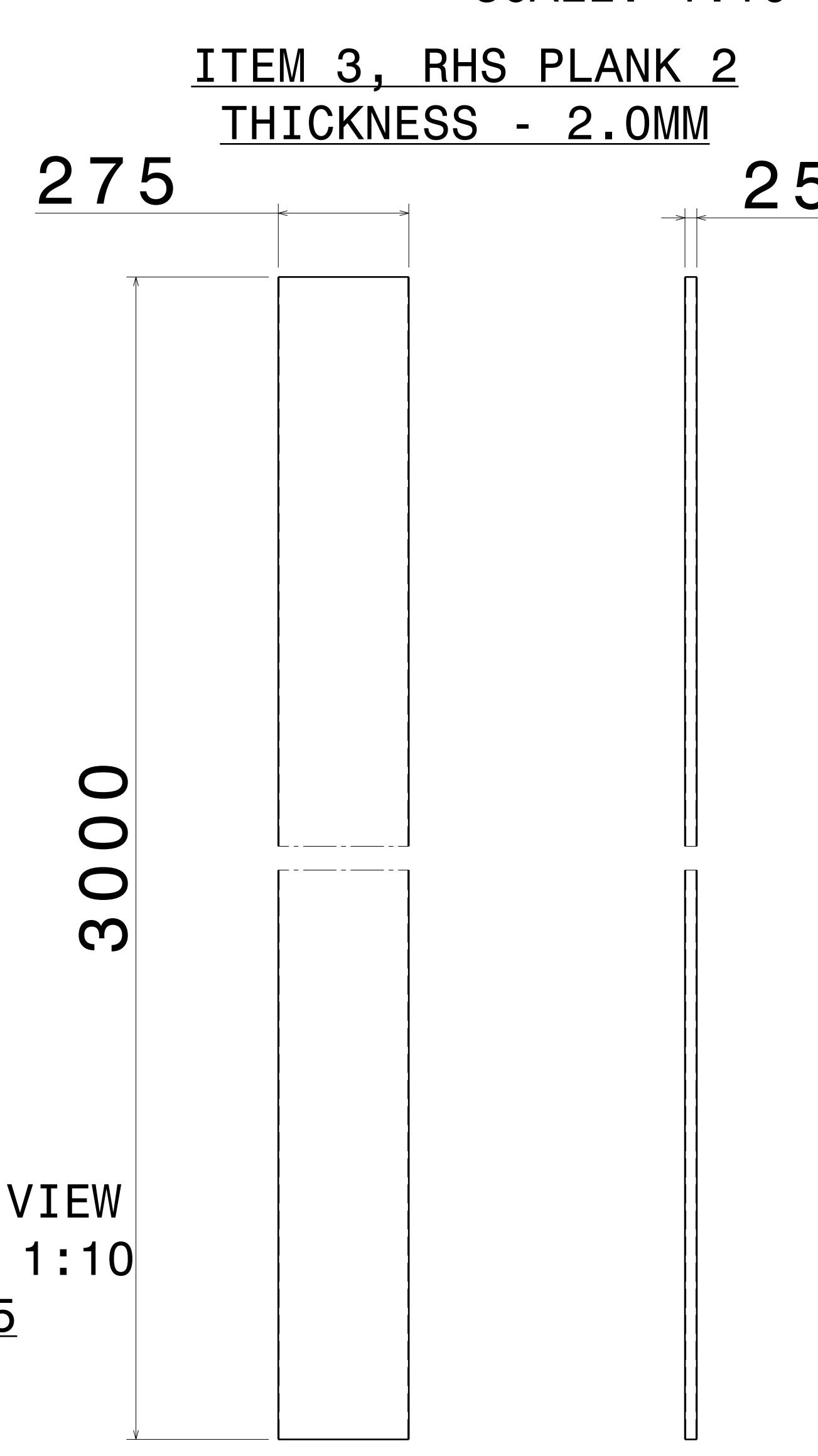

FRONT VIEW RIGHT VIEW
SCALE: 1:10 SCALE: 1:10
ITEM 12, RHS PLANK 7
THICKNESS - 2.0MM

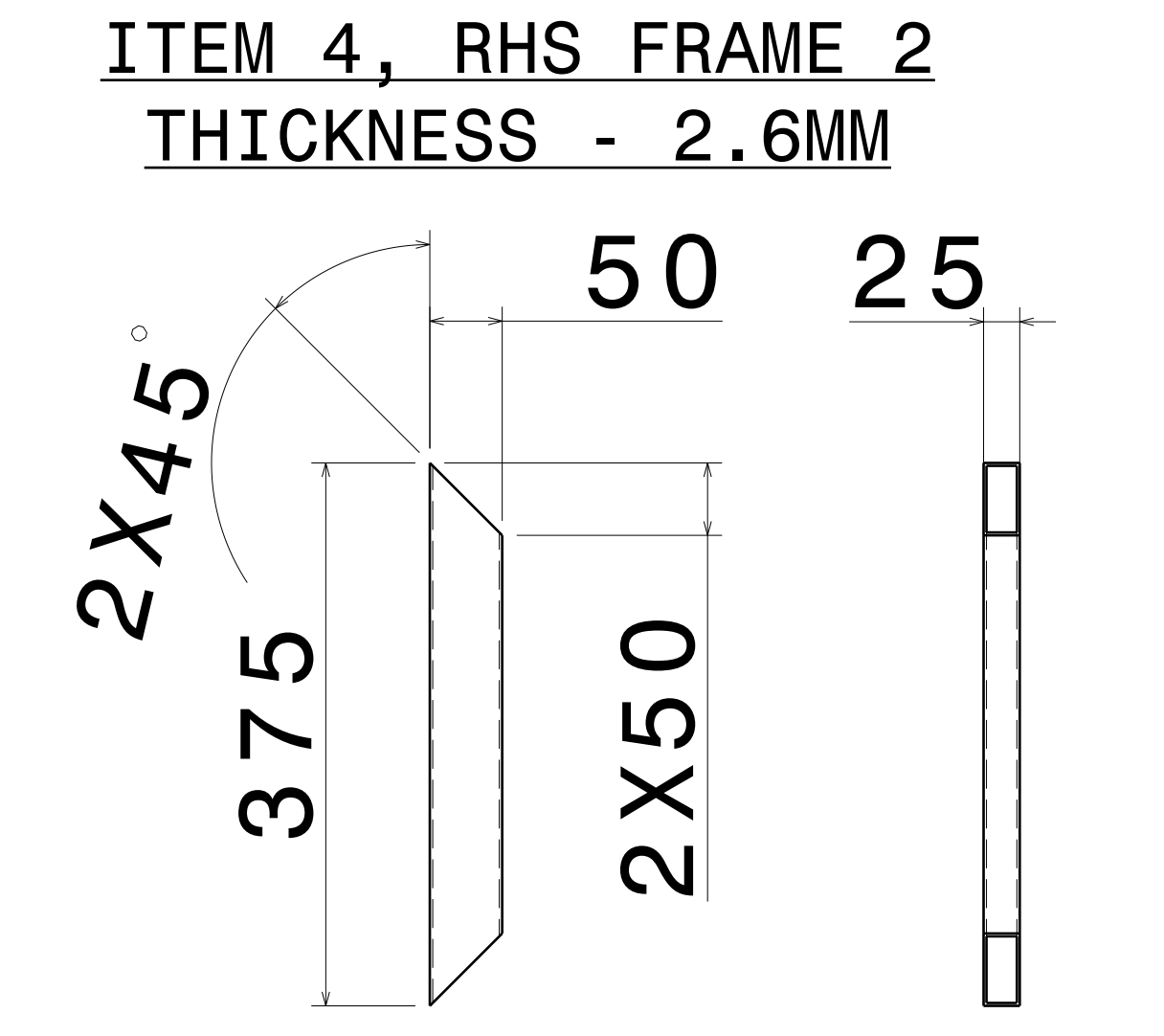

FRONT VIEW RIGHT VIEW
SCALE: 1:5 SCALE: 1:5
ITEM 13, RHS FRAME 6
THICKNESS - 2.0MM

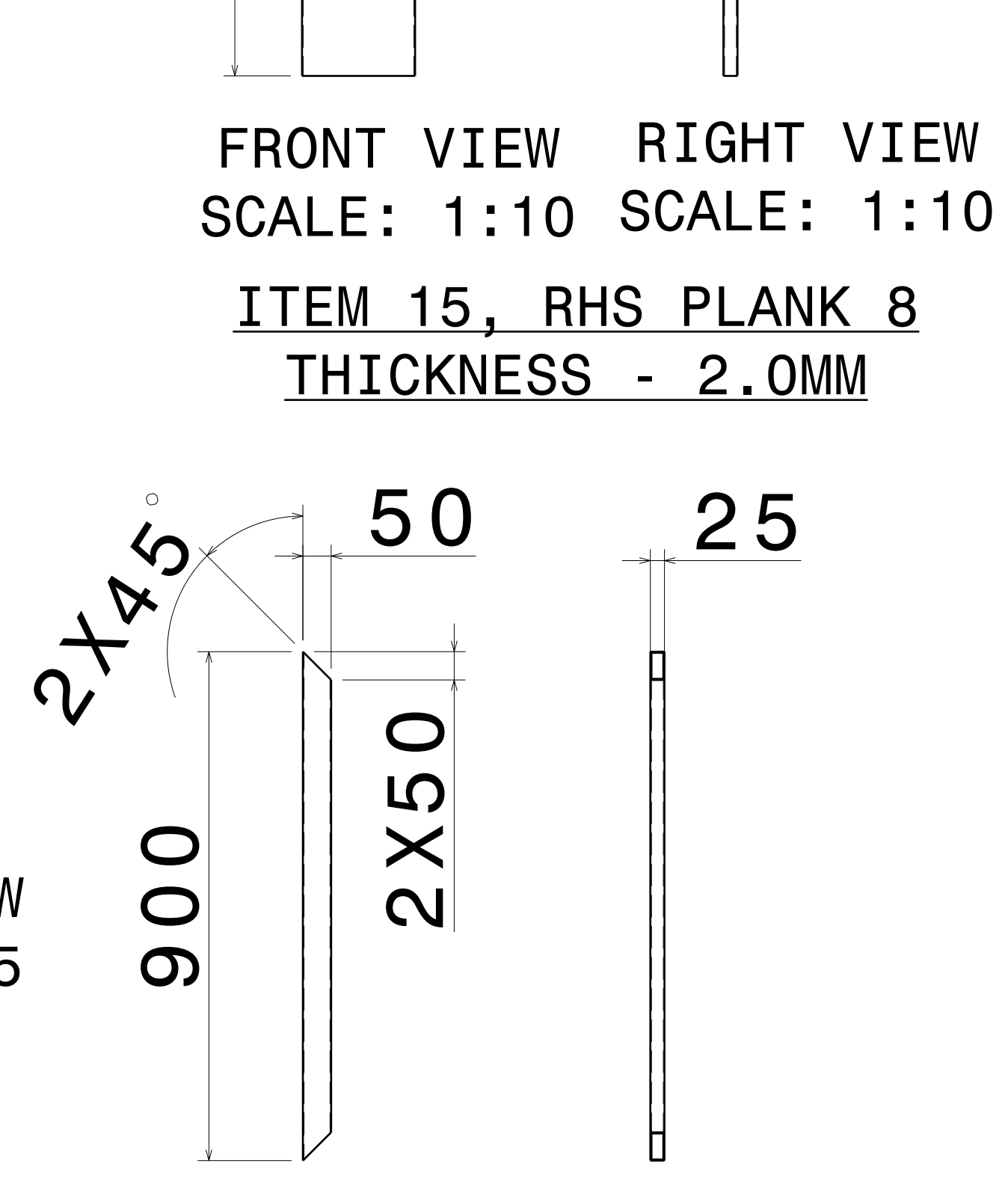

FRONT VIEW RIGHT VIEW FRONT VIEW RIGHT VIEW
SCALE: 1:10 SCALE: 1:10 SCALE: 1:10 SCALE: 1:10
ITEM 15, RHS PLANK 8 THICKNESS - 2.0MM
ITEM 16, RHS FRAME 8 THICKNESS - 2.0MM

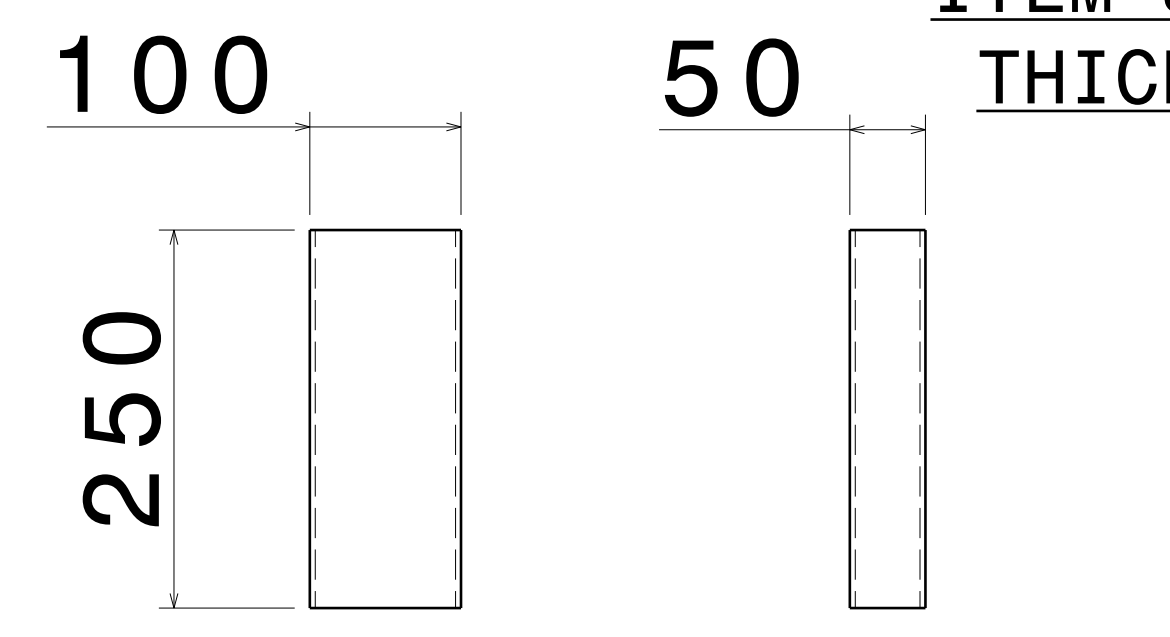

FRONT VIEW RIGHT VIEW
SCALE: 1:5 SCALE: 1:5
ITEM 17, RHS FRAME 9
THICKNESS - 2.0MM

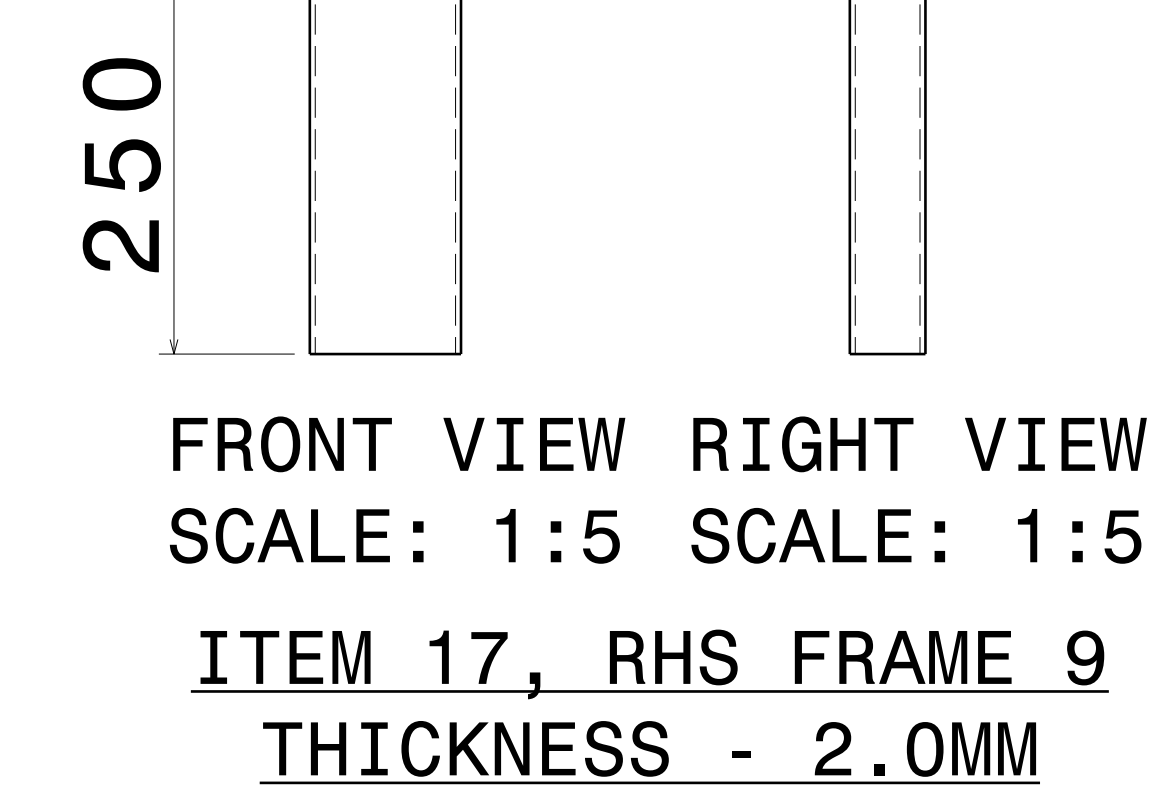

FRONT VIEW RIGHT VIEW
SCALE: 1:5 SCALE: 1:5
ITEM 18, RHS PLANK 9
THICKNESS - 2.0MM

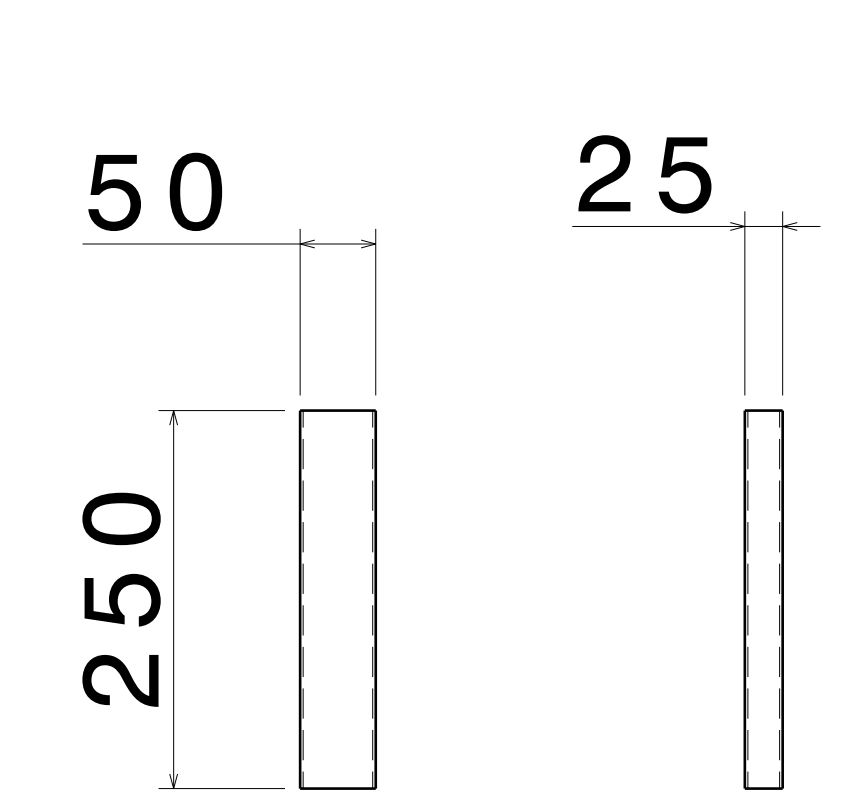

FRONT VIEW RIGHT VIEW
SCALE: 1:5 SCALE: 1:5
ITEM 19, RHS FRAME 10
THICKNESS - 2.0MM

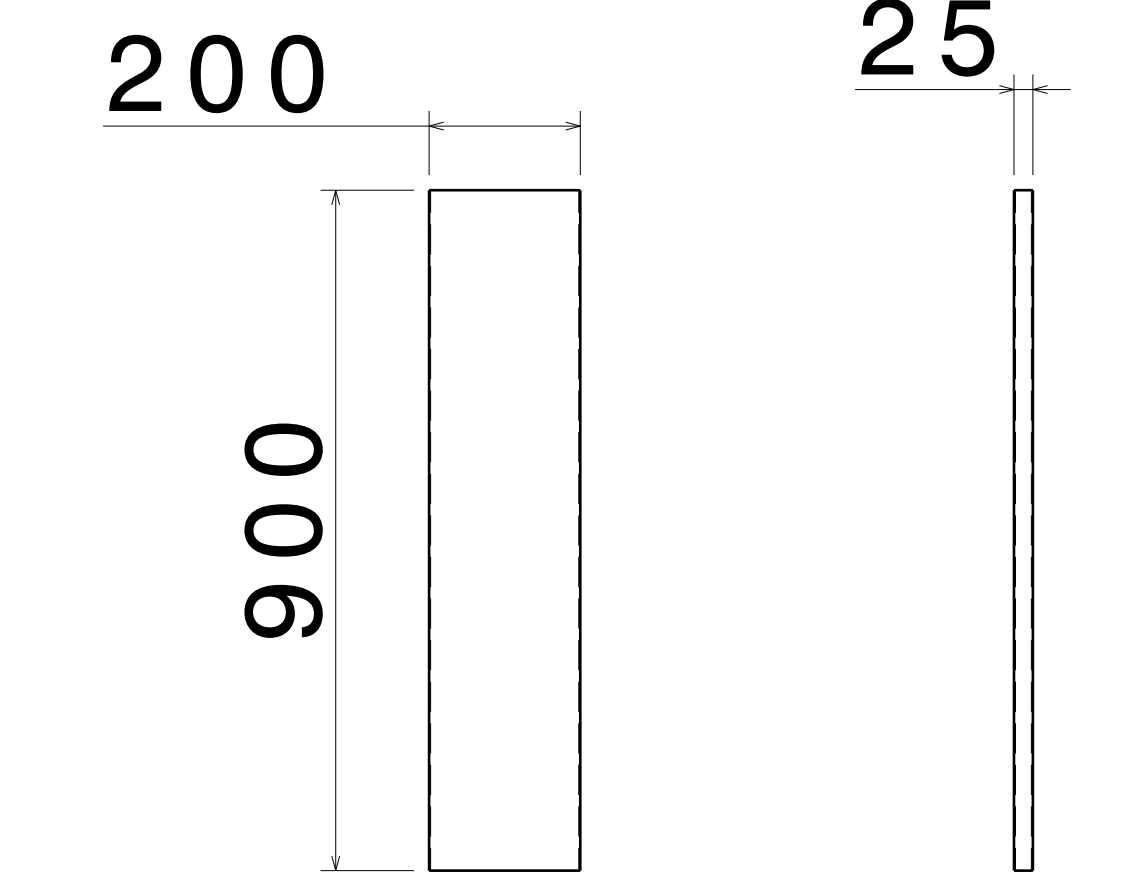

FRONT VIEW RIGHT VIEW
SCALE: 1:10 SCALE: 1:10
ITEM 10, RHS PLANK 6
THICKNESS - 2.0MM

UNLESS OTHERWISE SPECIFIED DIMENSION ARE IN MM VIEWS: THIRD ANGLE PROJECTION

This drawing is our property. It can't be reproduced or communicated without our written agreement.

DRAWN BY	DATE
SB	25NOV2020
CHECKED BY	DATE
P2P Analysis & Solutions	25NOV2020
DESIGNED BY	DATE
P2P Analysis & Solutions	25NOV2020

APL APOLLO TUBES LTD.	
DRAWING TITLE	
NOV 20 10-PARTITION AND SHELF	
SIZE	DRAWING NUMBER
A0	P2P NOV 20 10-PARTITION AND SHELF
SCALE	WEIGHT(kg)
NONE	XXX
SHEET 3 OF 3	

REV	DATE	DESCRIPTION
00	25NOV2020	INITIAL REVISION

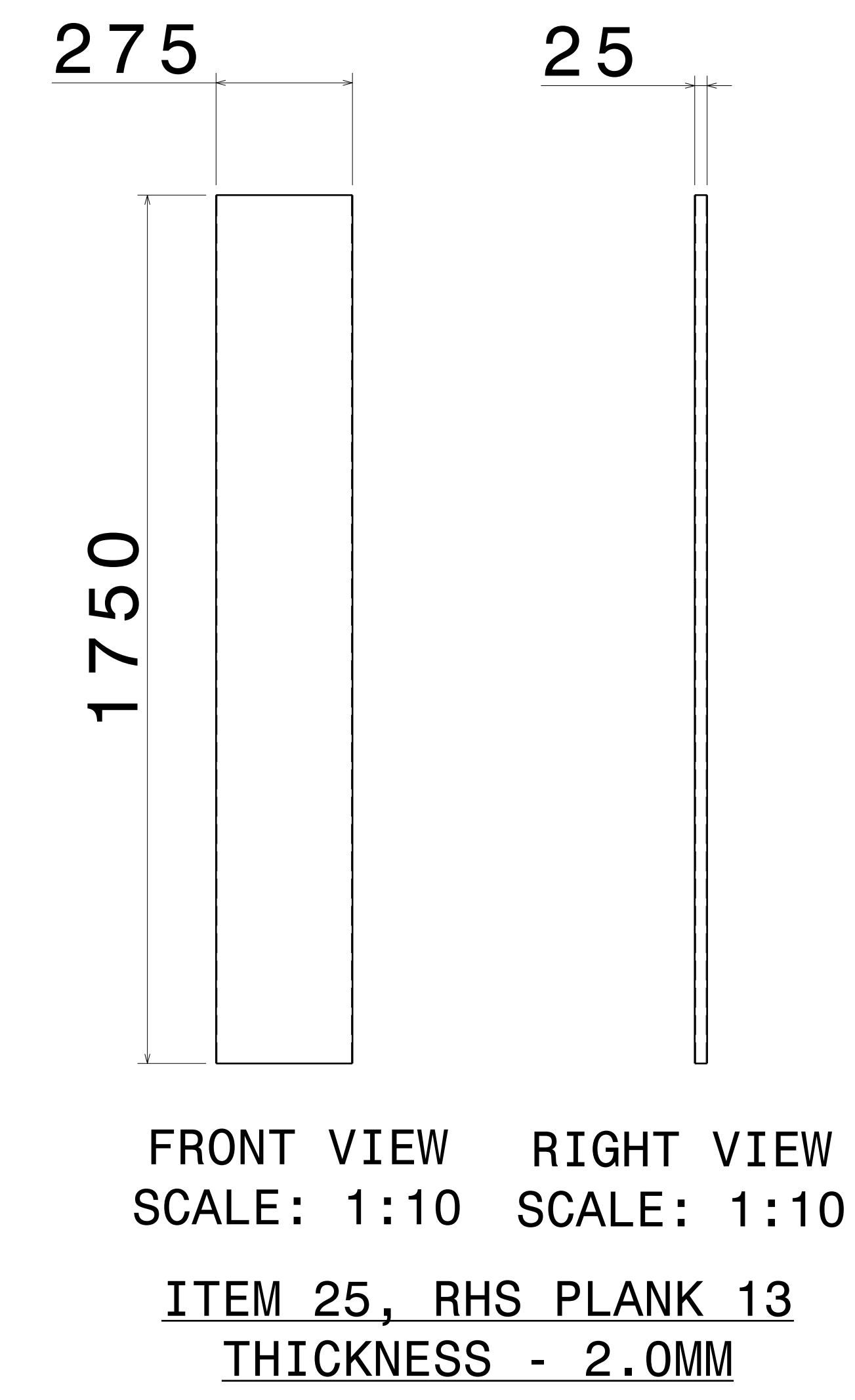
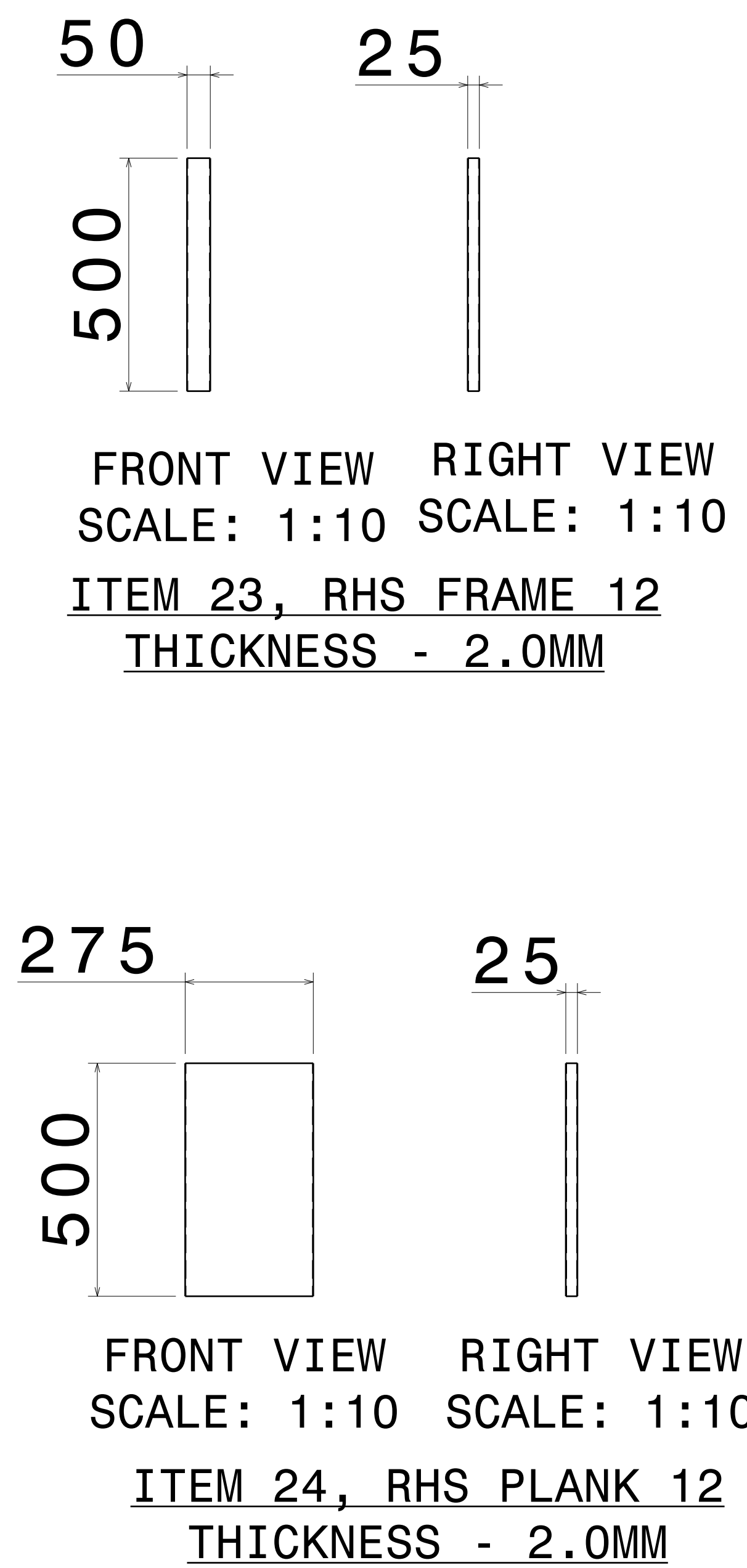
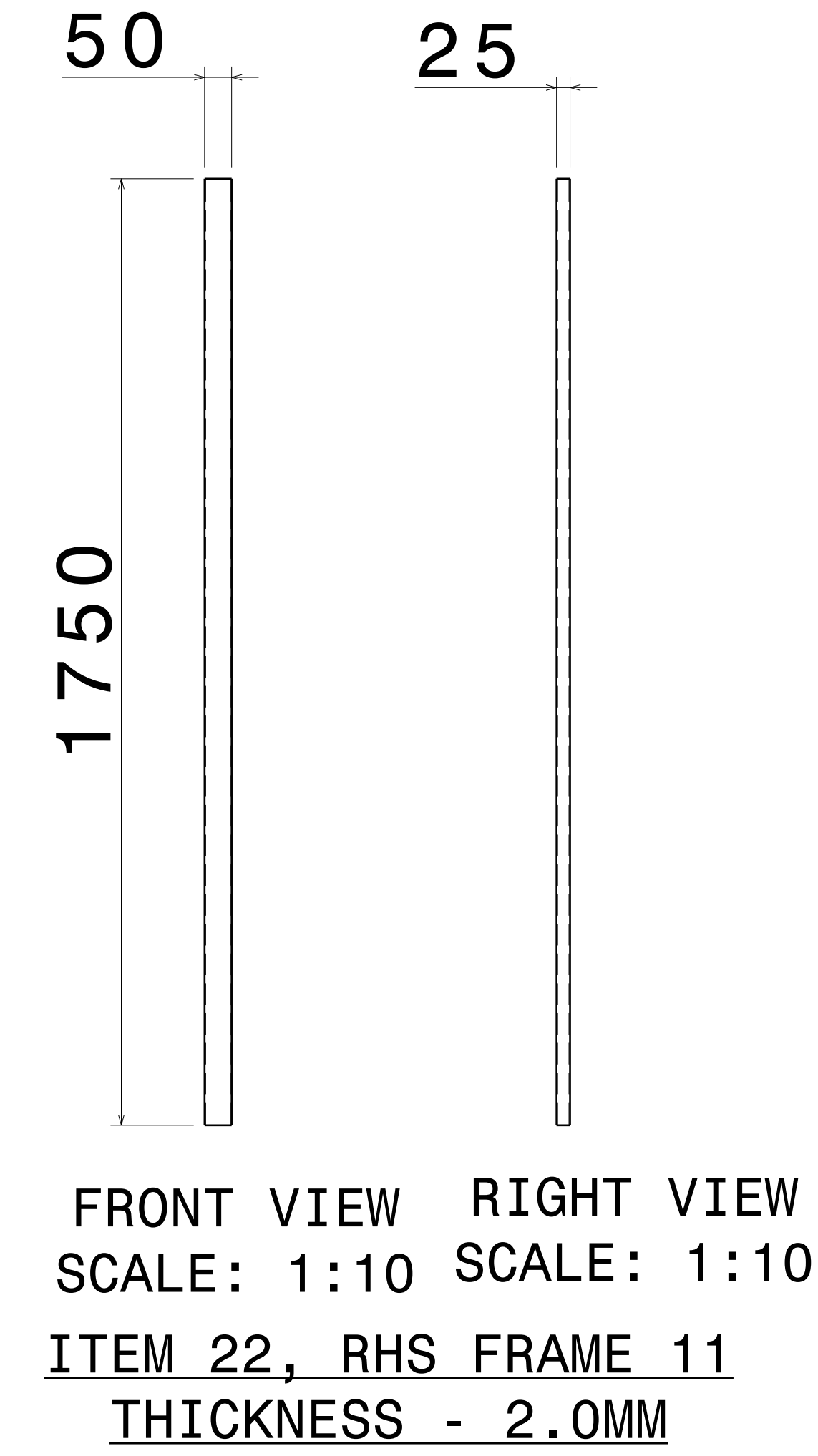
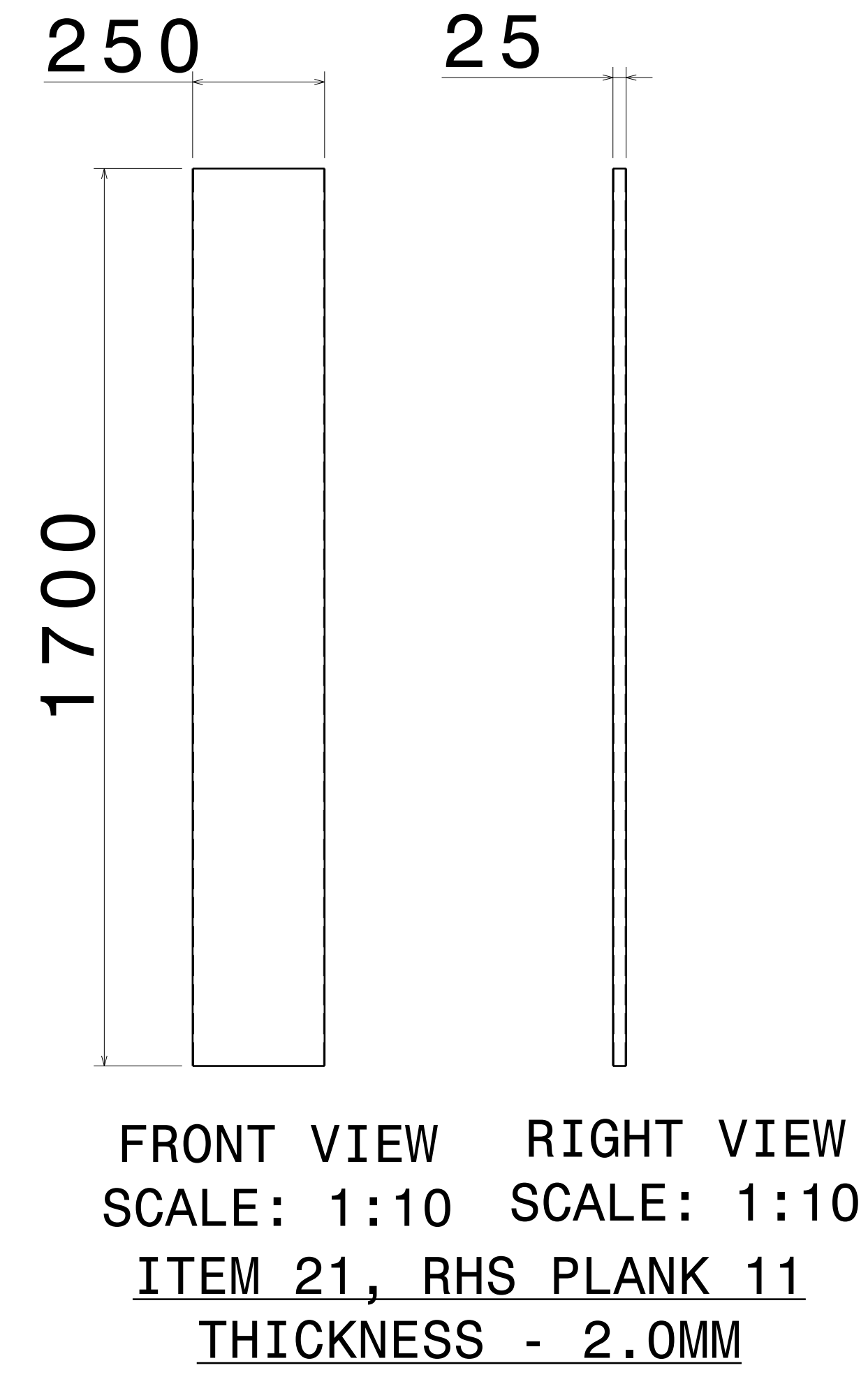
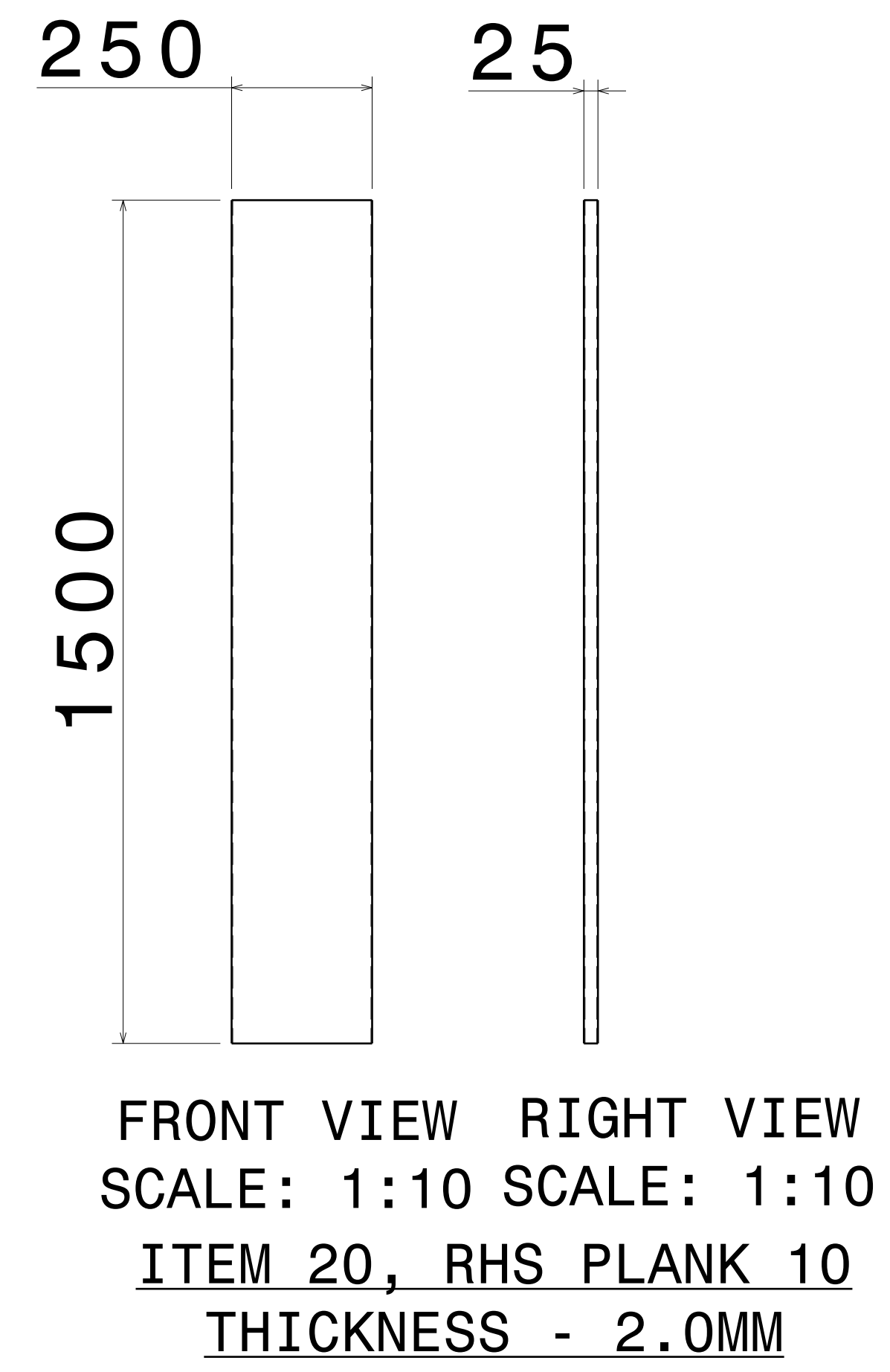

UNLESS OTHERWISE SPECIFIED DIMENSION ARE IN MM VIEWS: THIRD ANGLE PROJECTION

This drawing is our property. It can't be reproduced or communicated without our written agreement.		APL APOLLO TUBES LTD.	
DRAWN BY		DATE	
VM		25NOV2020	
CHECKED BY		DATE	
P2P Analysis & Solutions		25NOV2020	
DESIGNED BY		DATE	
P2P Analysis & Solutions		25NOV2020	
DRAWING TITLE		NOV 20_10-PARTITION AND SHELF	
SIZE		DRAWING NUMBER	
A0		P2P_NOV 20_10-PARTITION AND SHELF	
SCALE		WEIGHT(kg)	
As Indicated		0kg	
REV		SHEET 1 OF 3	
00			