

REV/DATE	DESCRIPTION
00 11NOV2020	INITIAL REVISION

- NOTES:
- (⊥) ALL VERTICAL SUPPORTS ARE PERPENDICULAR.
 - FLATNESS OF .5MM IS APPLIED BY DEFAULT.
 - ⊲ WELD BEAD OF 2MM RADIUS IS FOLLOWED.
 - ▽ SURFACE FINISH MEDIUM TO SMOOTH IS USED.
 - ALL TUBES ARE AS PER APL APOLLO STANDARD. CHANGES MAY EFFECT THE LOAD CAPACITY.
 - ALL HORIZONTAL AND VERTICAL TUBES ARE PERPENDICULAR TO EACH OTHER WITH ±1 DEG.
 - FINE WELDNG IS REQUIRED AS PER MENTIONED DETAILS AND FINISHING.
 - HIGHER CURRENT WELDING MAY AFFECT THE BRITTLNESS OF MATERIAL WHICH LATER MAY RAISE TO WEAKENING OF STRUCTURE.
 - FABRICATORS ARE ALLOWED TO USE FITTINGS/FRAMES/SUPPORTS AS NEEDED AND THE SAME MUST BE COMMUNICATED BACK TO ENGINEERING TEAM.
 - BOP COMPONENT WEIGHTS ARE FOR REFERENCE ONLY AND SUBJECTED TO CHANGE PER PURCHASED COMPONENTS.

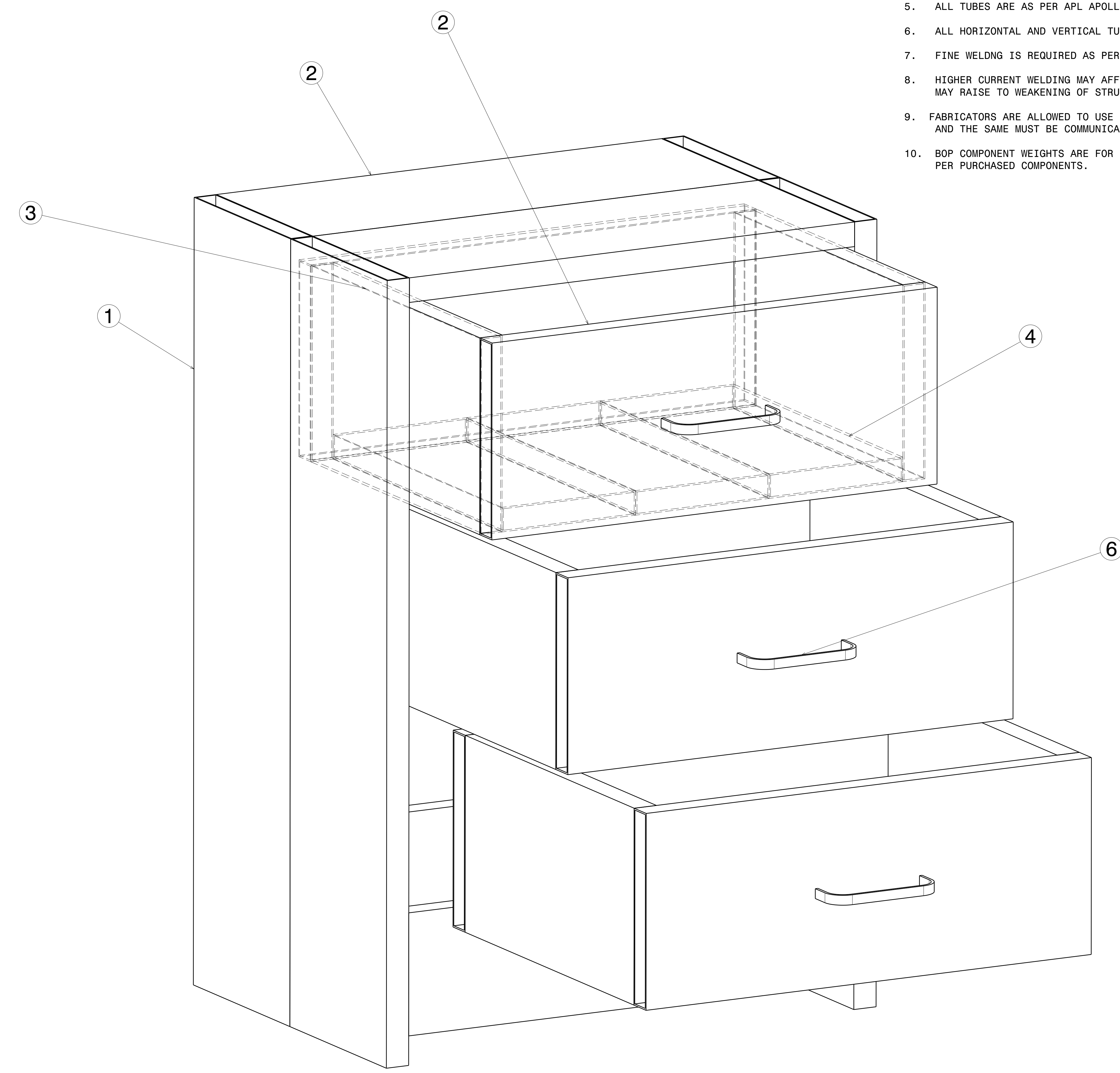

ISOMETRIC VIEW



EXPLODED VIEW

ITEM NO.	PART NUMBER	DESCRIPTION	QTY.	Wt (kg)/Each
6	HANDLE BOP	---	---	---
5	PLANK 5	125 X 25 X 1.6 X 500	2	1.85
4	PLANK 4	150 X 25 X 1.6 X 350	9	1.51
3	PLANK 3	200 X 25 X 1.6 X 350	6	1.9
2	PLANK 2	200 X 25 X 1.6 X 500	8	2.8
1	PLANK 1	200 X 25 X 1.6 X 800	2	4.46

This drawing is our property. It can't be reproduced or communicated without our written agreement.		APL APOLLO TUBES LTD.	
DRAWN BY: SB		DATE: 11NOV2020	
CHECKED BY: P2P Analysis & Solutions		DATE: 11NOV2020	
DESIGNED BY: P2P Analysis & Solutions		DATE: 11NOV2020	
DRAWING TITLE: NOV 20 14		SIZE: A0	REV: 00
DRAWING NUMBER: P2P NOV 20 14		SCALE: As Indicated	WEIGHT(kg): 0kg
		SHEET 1 OF 3	

UNLESS OTHERWISE SPECIFIED DIMENSION ARE IN MM
 VIEWS: THIRD ANGLE PROJECTION

REV	DATE	DESCRIPTION
00	11NOV2020	INITIAL REVISION

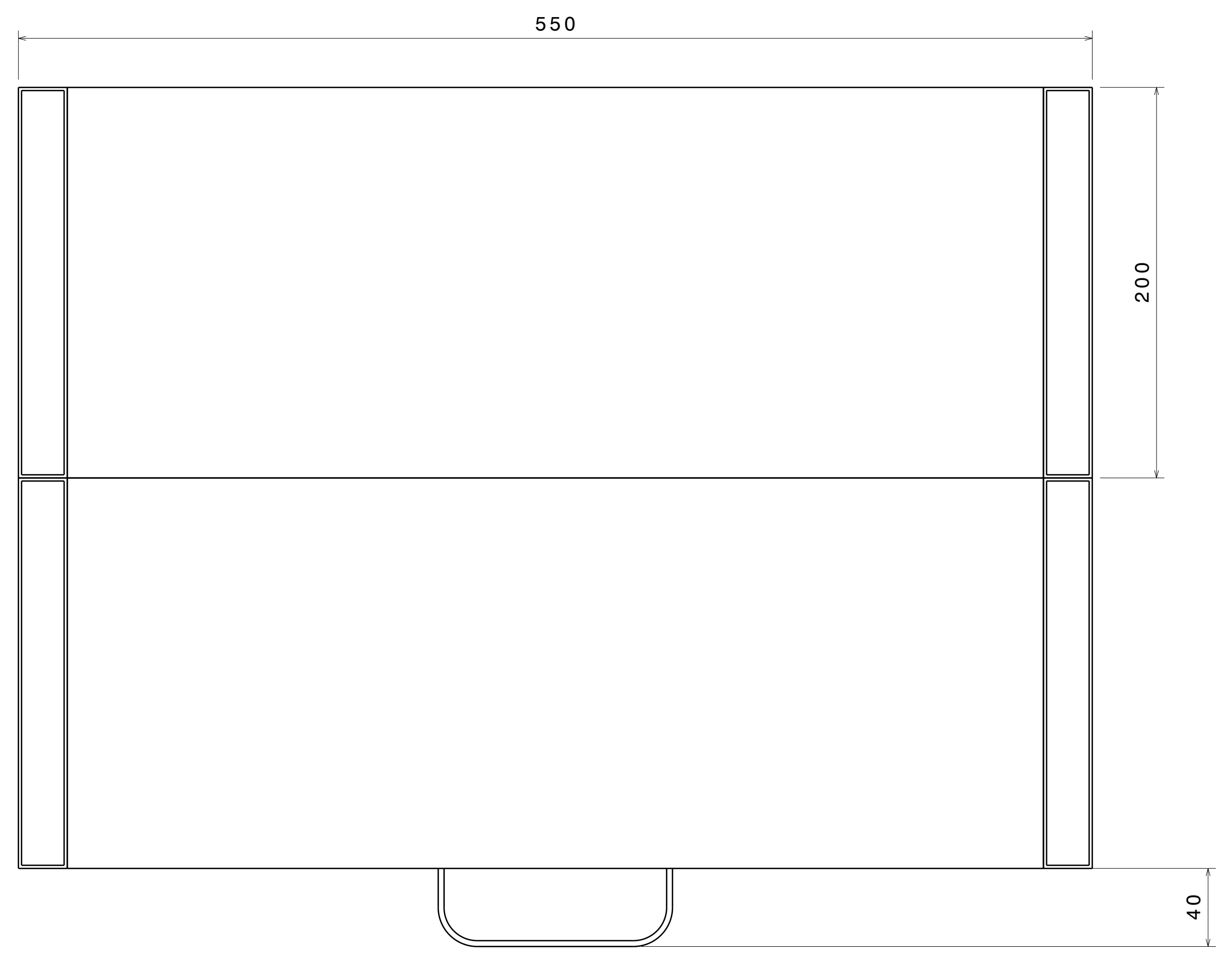

Top view
Scale: 1:2

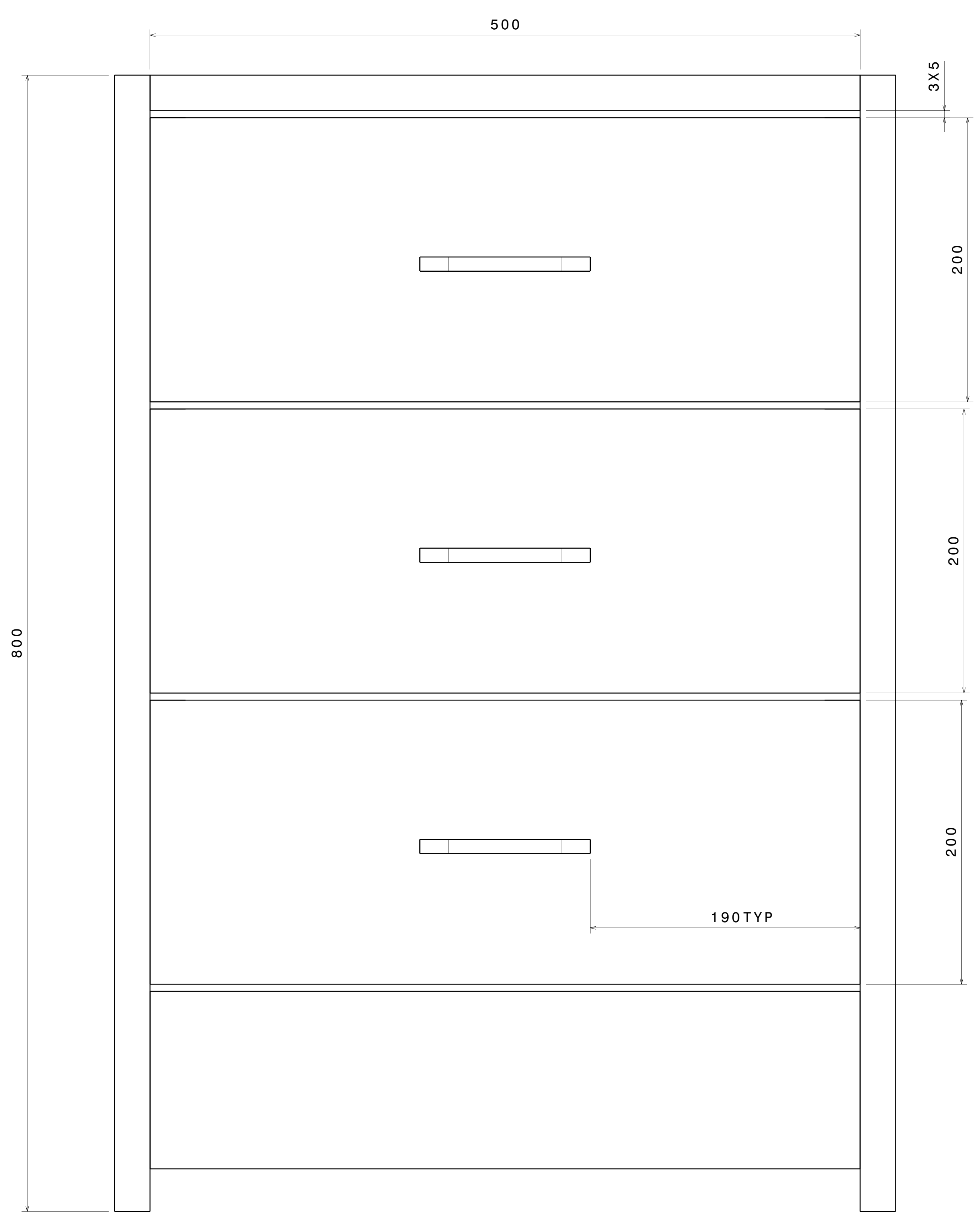

Front view
Scale: 1:2

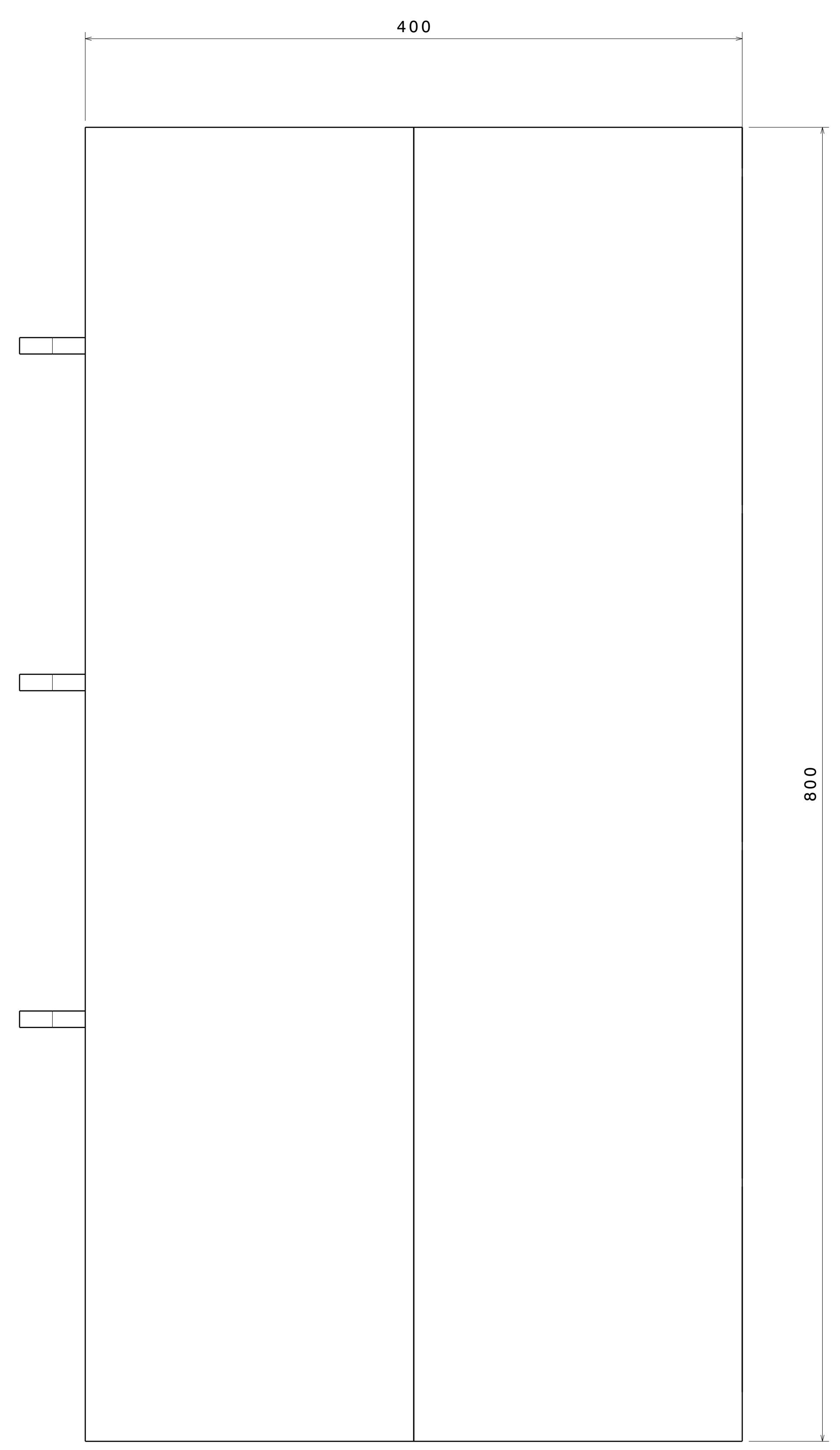

Right view
Scale: 1:2

UNLESS OTHERWISE SPECIFIED DIMENSION ARE IN MM
VIEWS: THIRD ANGLE PROJECTION

This drawing is our property. It can't be reproduced or communicated without our written agreement.		APL APOLLO TUBES LTD.	
DRAWN BY SB		DATE 11NOV2020	
CHECKED BY P2P Analysis & Solutions		DATE 11NOV2020	
DESIGNED BY P2P Analysis & Solutions		DATE 11NOV2020	
DRAWING TITLE NOV 20_14		SIZE A0	REV 00
SCALE NONE		WEIGHT (kg) XXX	SHEET 2 OF 3

REV	DATE	DESCRIPTION
00	11NOV2020	INITIAL REVISION

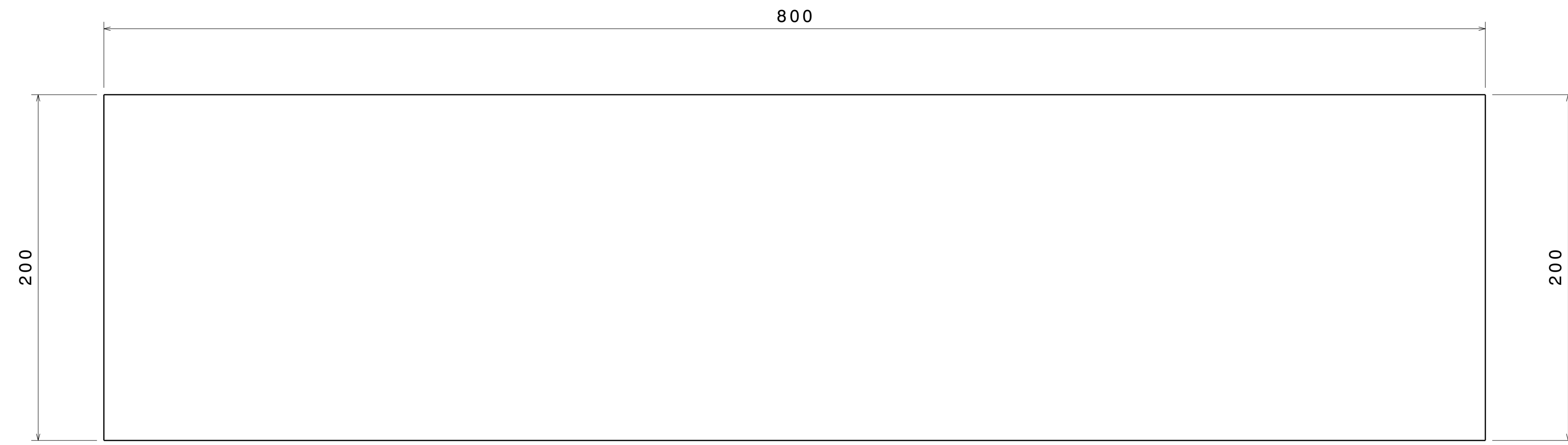

ITEM 1

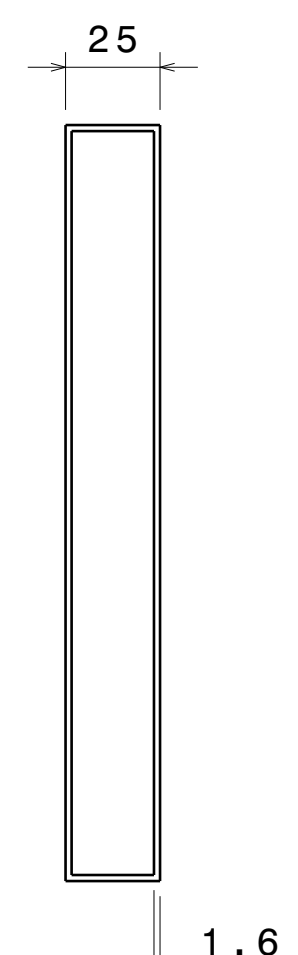

Right view
Scale: 1:2

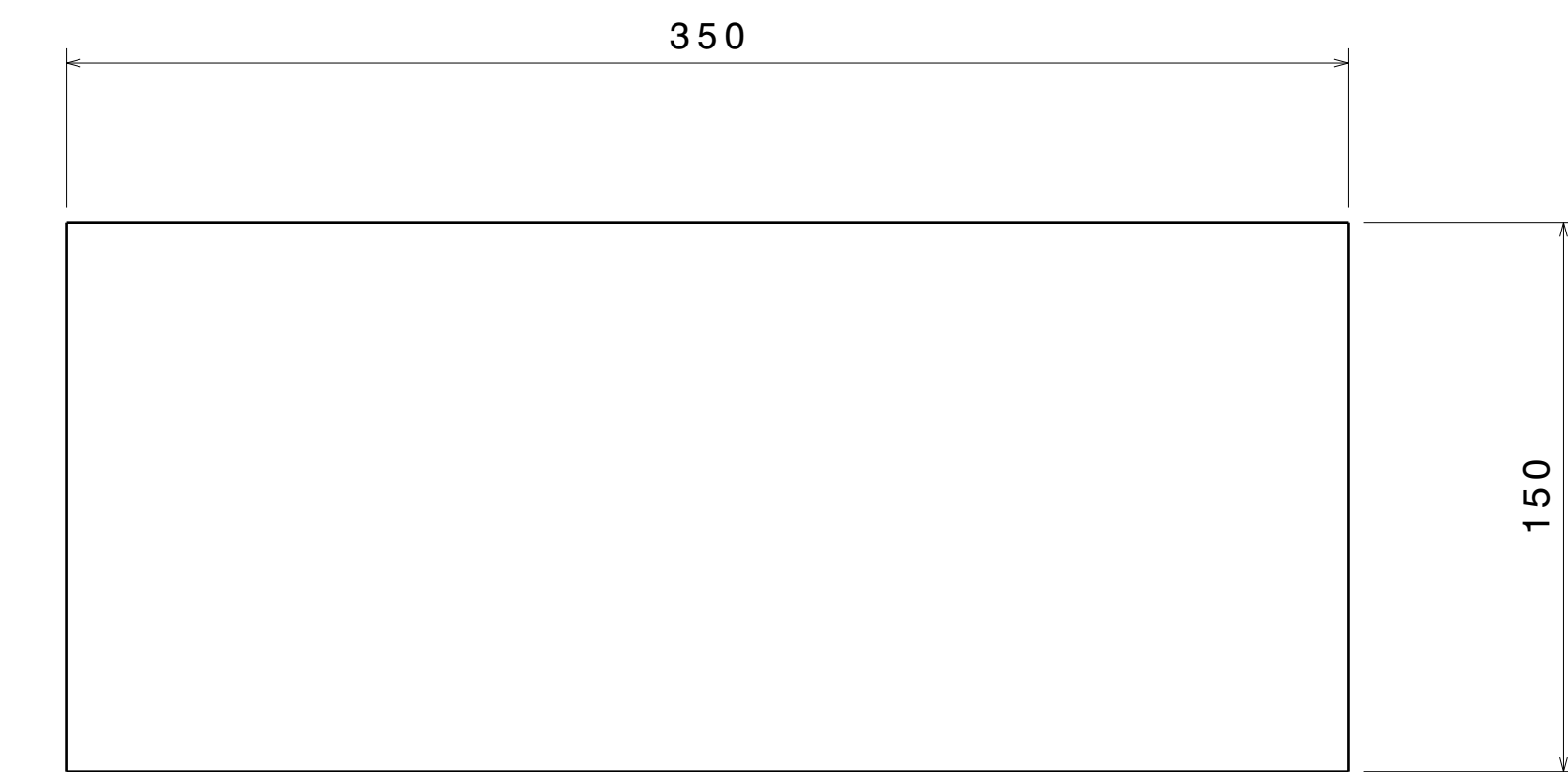

ITEM 4

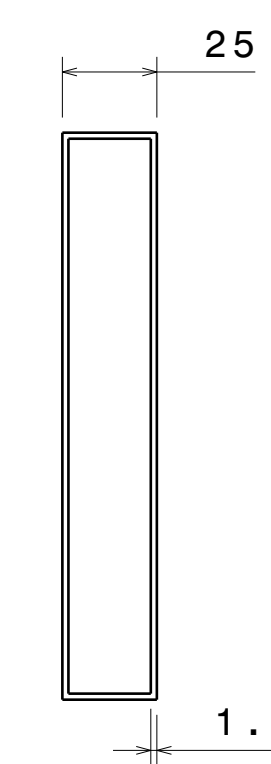

Right view
Scale: 1:2

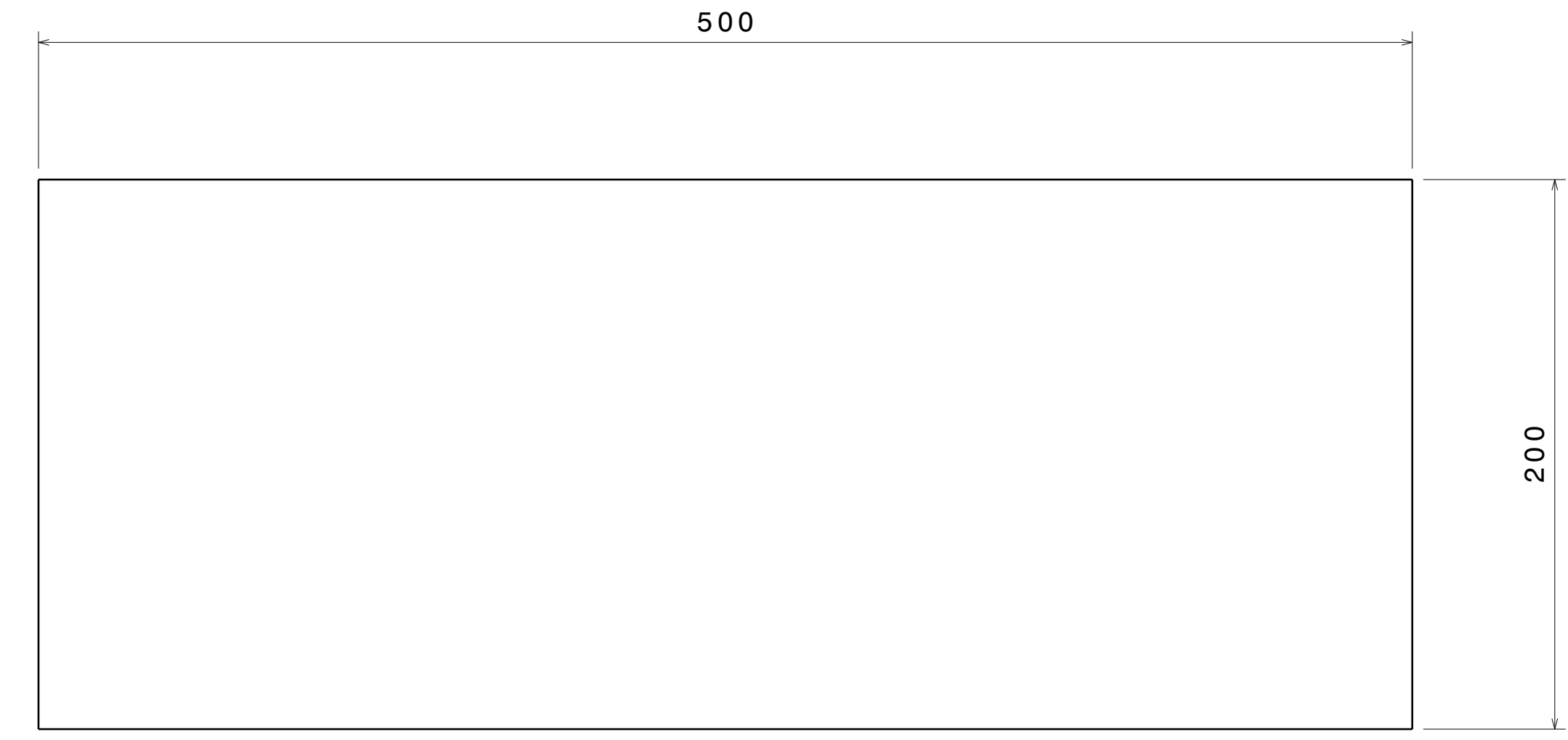

ITEM 2

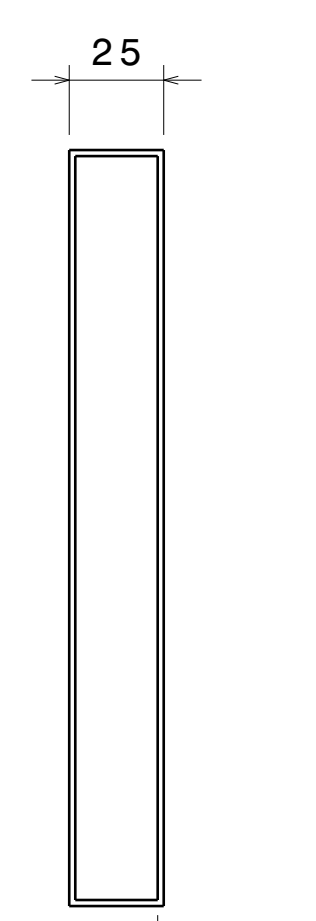

Right view
Scale: 1:2

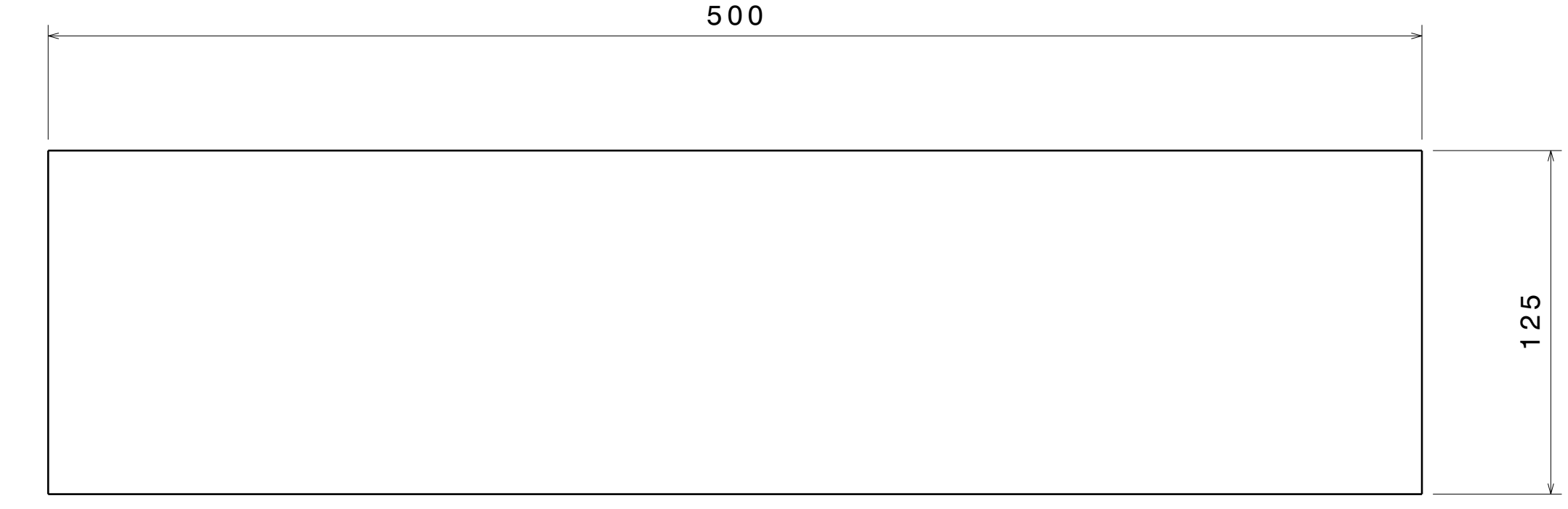

ITEM 5

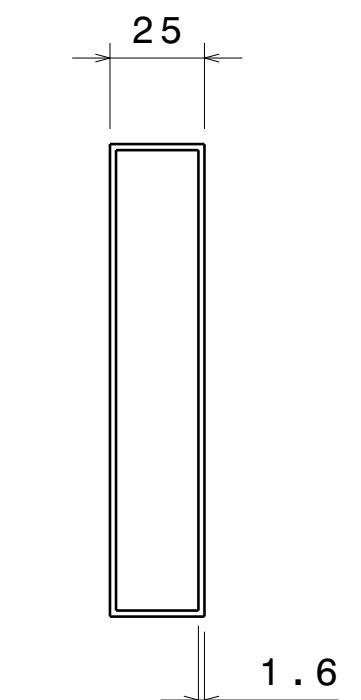

Right view
Scale: 1:2

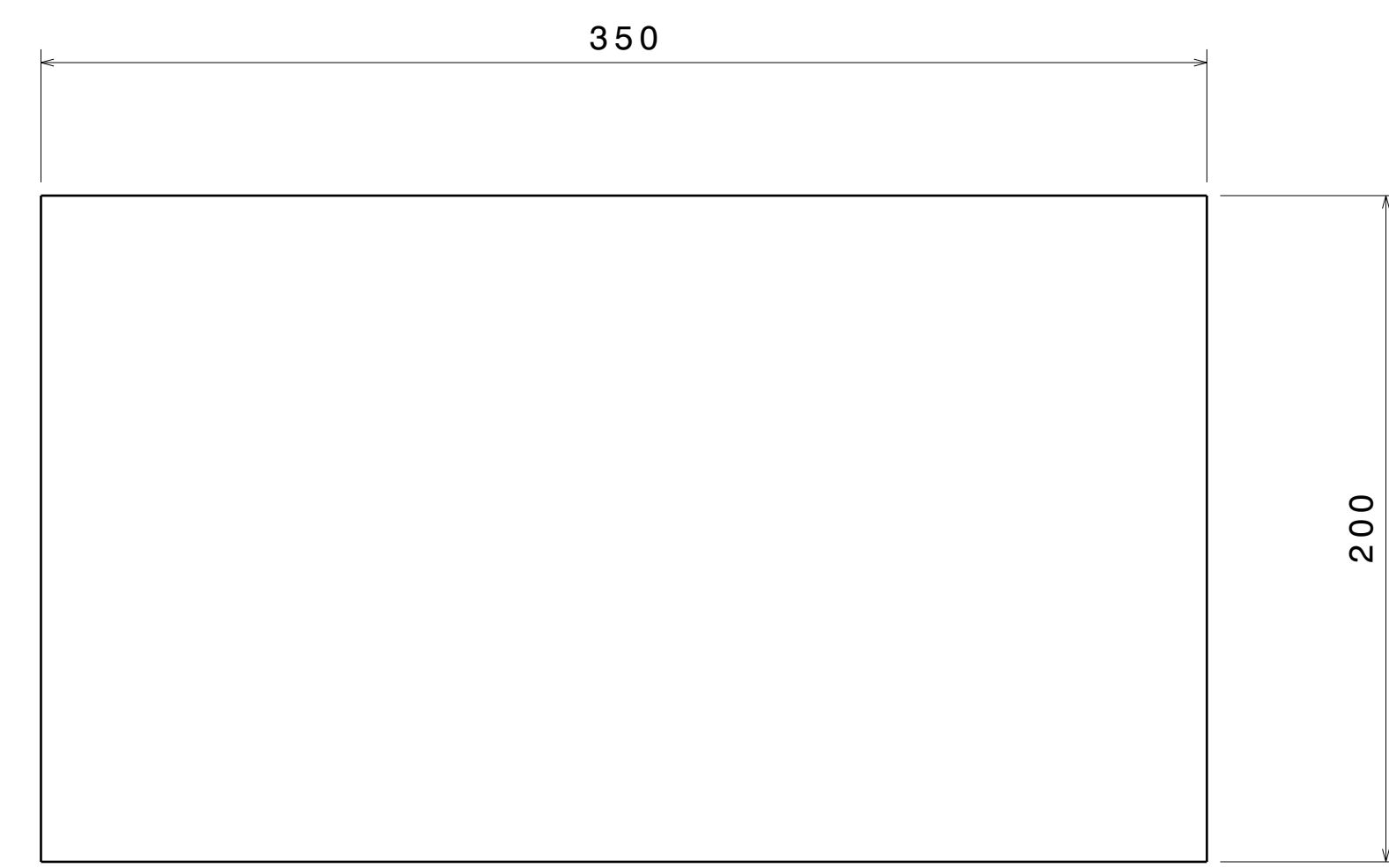

ITEM 3

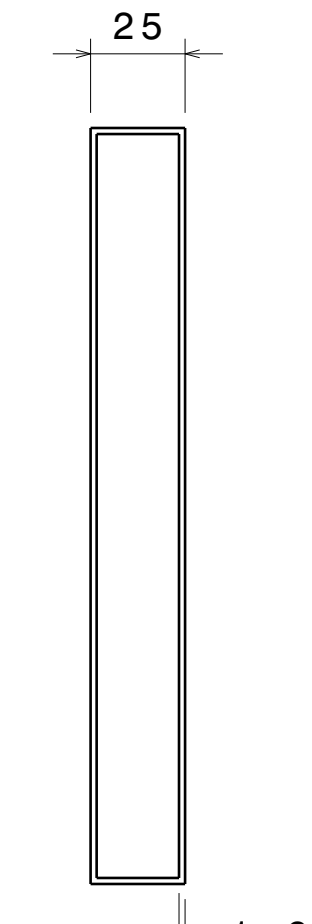

Right view
Scale: 1:2

This drawing is our property.
It can't be reproduced
or communicated without
our written agreement.

APL APOLLO TUBES LTD. 

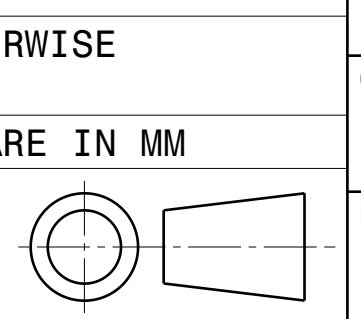
UNLESS OTHERWISE
SPECIFIED
DIMENSION ARE IN MM
VIEWS:
THIRD ANGLE
PROJECTION 

DRAWN BY	DATE	DRAWING TITLE	
SB	11NOV2020	NOV 20 14	
CHECKED BY	DATE	SIZE	DRAWING NUMBER
P2P Analysis & Solutions	11NOV2020	A0	P2P NOV 20 14
DESIGNED BY	DATE	SCALE	WEIGHT (kg)
P2P Analysis & Solutions	11NOV2020	NONE	XXX
		SHEET 3 OF 3	

REV
00