

REV/DATE	DESCRIPTION
00 / 22NOV2020	INITIAL REVISION

NOTES:

- (⊥) ALL VERTICAL SUPPORTS ARE PERPENDICULAR.
- FLATNESS OF .5MM IS APPLIED BY DEFAULT.
- ∇ WELD BEAD OF 2MM RADIUS IS FOLLOWED.
- ▽▽ SURFACE FINISH MEDIUM TO SMOOTH IS USED.
- ALL TUBES ARE AS PER APL APOLLO STANDARD. CHANGES MAY EFFECT THE LOAD CAPACITY.
- ALL HORIZONTAL AND VERTICAL TUBES ARE PERPENDICULAR TO EACH OTHER WITH ±1 DEG.
- FINE WELDING IS REQUIRED AS PER MENTIONED DETAILS AND FINISHING.
- HIGHER CURRENT WELDING MAY AFFECT THE BRITTLENESS OF MATERIAL WHICH LATER MAY RAISE TO WEAKENING OF STRUCTURE.
- FABRICATORS ARE ALLOWED TO USE FITTINGS/FRAMES/SUPPORTS AS NEEDED AND THE SAME MUST BE COMMUNICATED BACK TO ENGINEERING TEAM.
- LENGTH OF ALL LONGITUDINAL FRAMES ARE FOR REFERENCE ONLY AND SUBJECTED TO CHANGE PER REQUIREMENT.

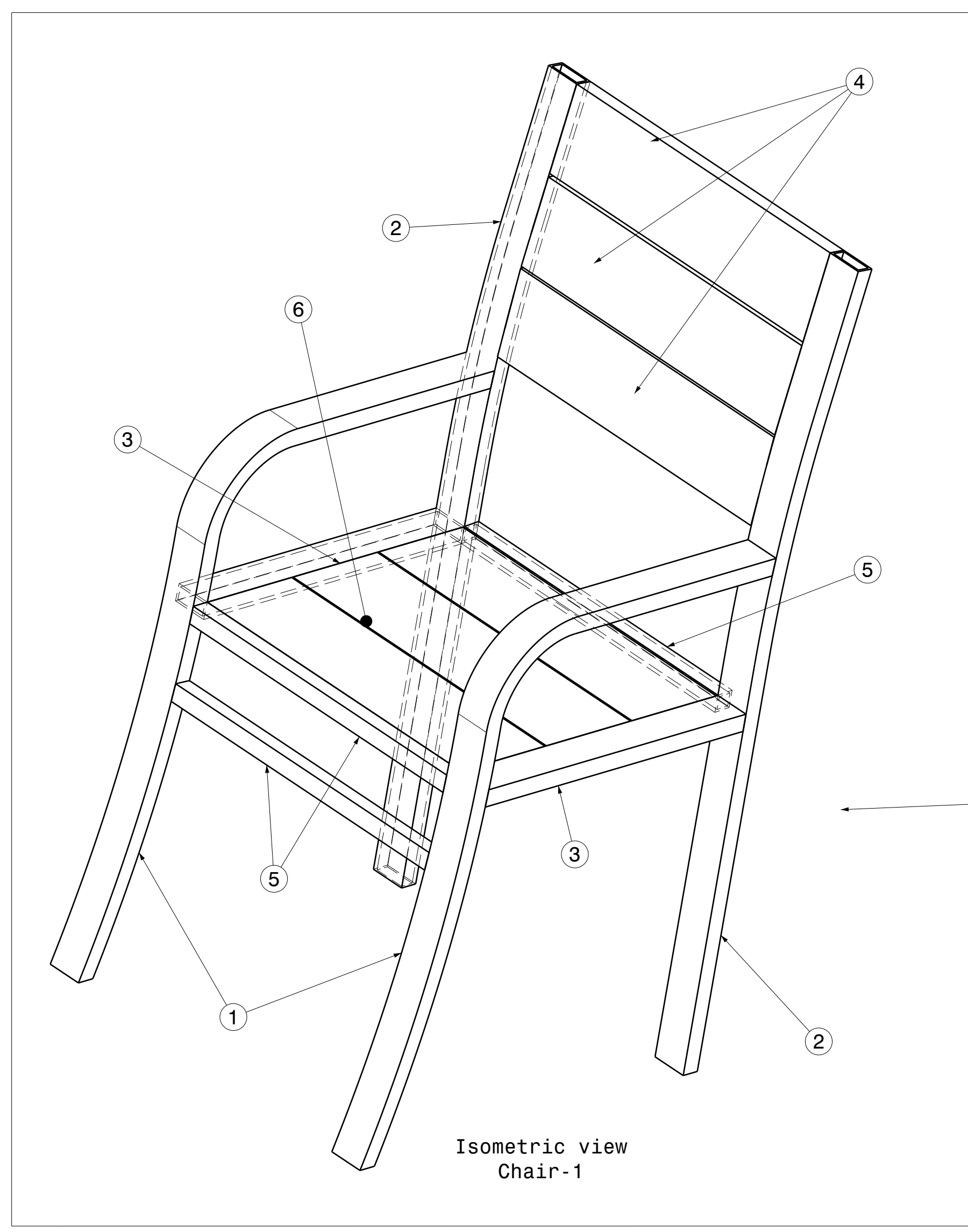

Isometric view  
Chair-1

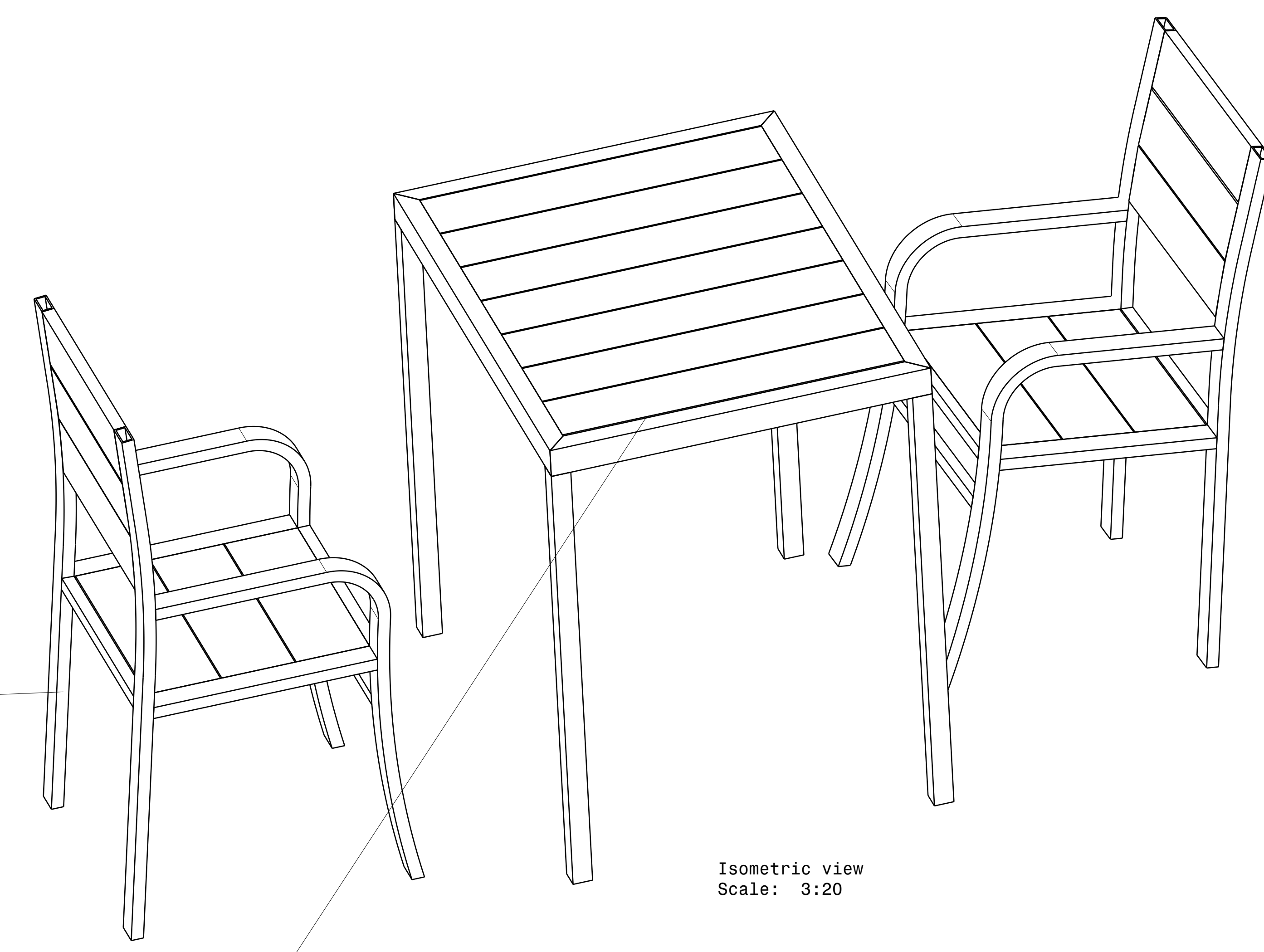

Isometric view  
Scale: 3:20

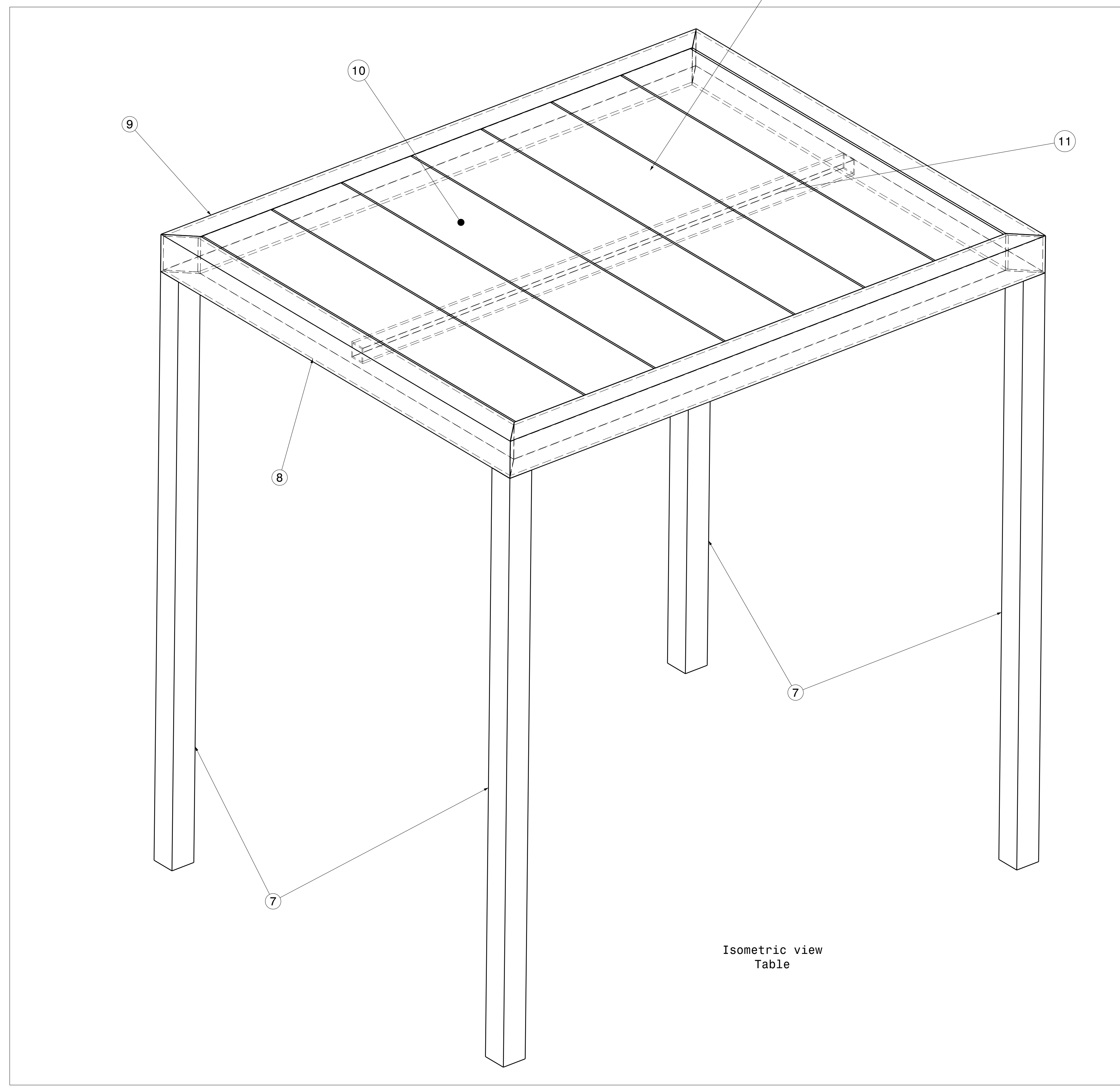

Isometric view  
Table

ITEM NO.	PART NUMBER	DESCRIPTION	QTY.	Wt (Kg)/Each
11	Sq Tube Chair & Table Frame 3	25 X 25 X 2 X 900	1	1.3
10	Table Plank 1	125 X 25 X 1.6 X 700	7	2.58
9	Rect Tube Chair & Table Frame 5	60 X 40 X 2.6 X 980	2	3.64
8	Rect Tube Chair & Table Frame 4	60 X 40 X 2.6 X 780	2	2.87
7	Sq Tube Chair & Table Frame 2	40 X 40 X 3.2 X 950	4	3.5
6	Chair Plank 2	150 X 25 X 1.6 X 450	2	1.95
5	Sq Tube Chair & Table Frame 1	25 X 25 X 3.2 X 450	6	0.98
4	Chair Plank 1	125 X 25 X 1.6 X 450	6	1.66
3	Rect Tube Chair & Table Frame 3	50 X 25 X 3.2 X 460	4	1.6
2	Rect Tube Chair & Table Frame 2	50 X 25 X 3.2 X 1156	4	3.9
1	Rect Tube Chair & Table Frame 1	50 X 25 X 3.2 X 1175	4	4.0

This drawing is our property. It can't be reproduced or communicated without our written agreement.		APL APOLLO TUBES LTD. 	
DRAWN BY: SB		DATE: 22NOV2020	
CHECKED BY: P2P Analysis & Solutions		DATE: 22NOV2020	
DESIGNED BY: P2P Analysis & Solutions		DATE: 22NOV2020	
DRAWING TITLE: NOV 20 15		SIZE: A0	DRAWING NUMBER: P2P NOV 20 15
SCALE: As Indicated		WEIGHT (kg): 0kg	SHEET 1 OF 3

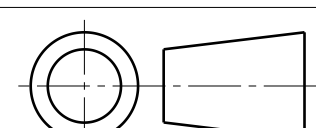
UNLESS OTHERWISE SPECIFIED DIMENSION ARE IN MM VIEWS: THIRD ANGLE PROJECTION 

REV	DATE	DESCRIPTION
00	22NOV2020	INITIAL REVISION

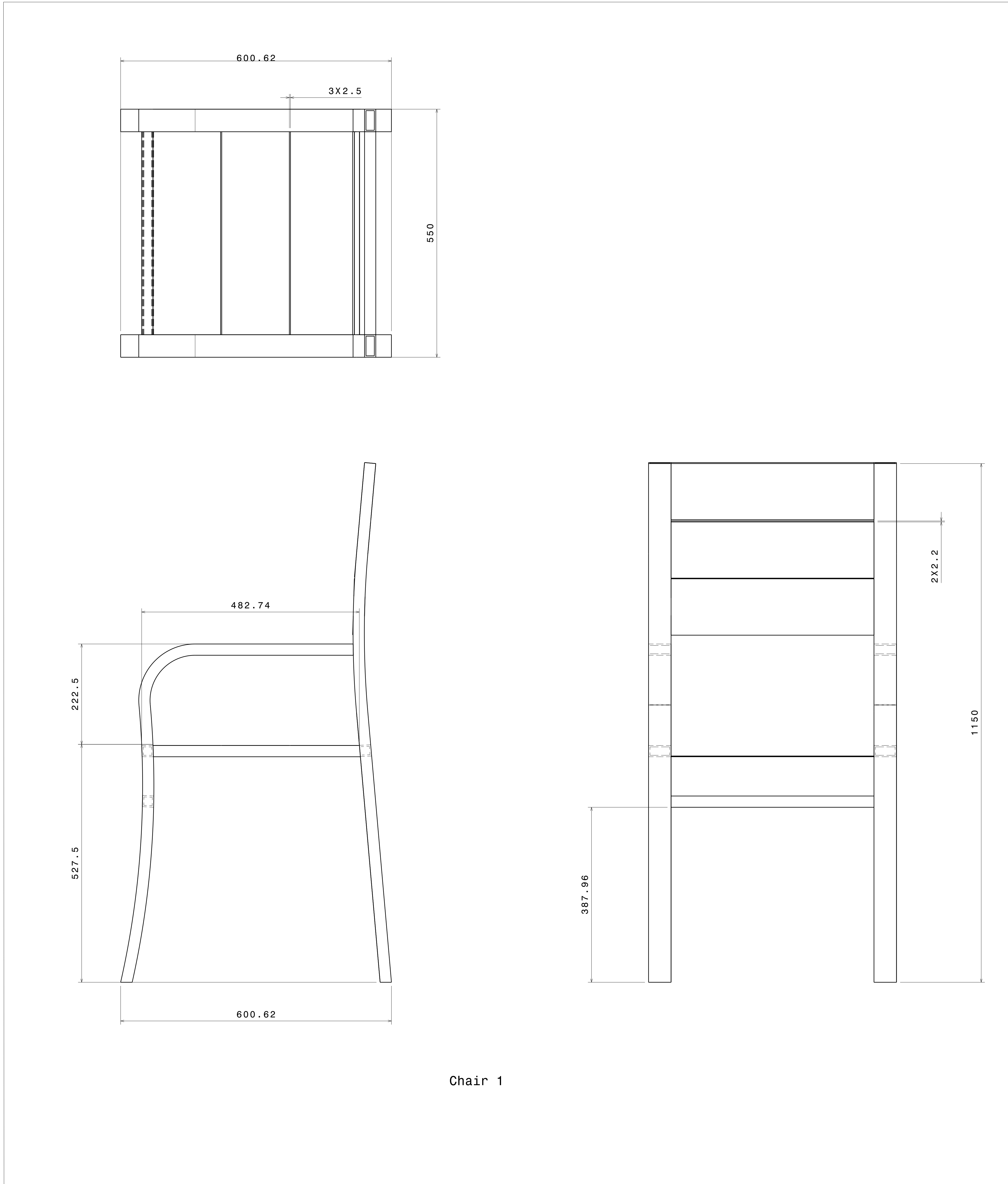

Chair 1

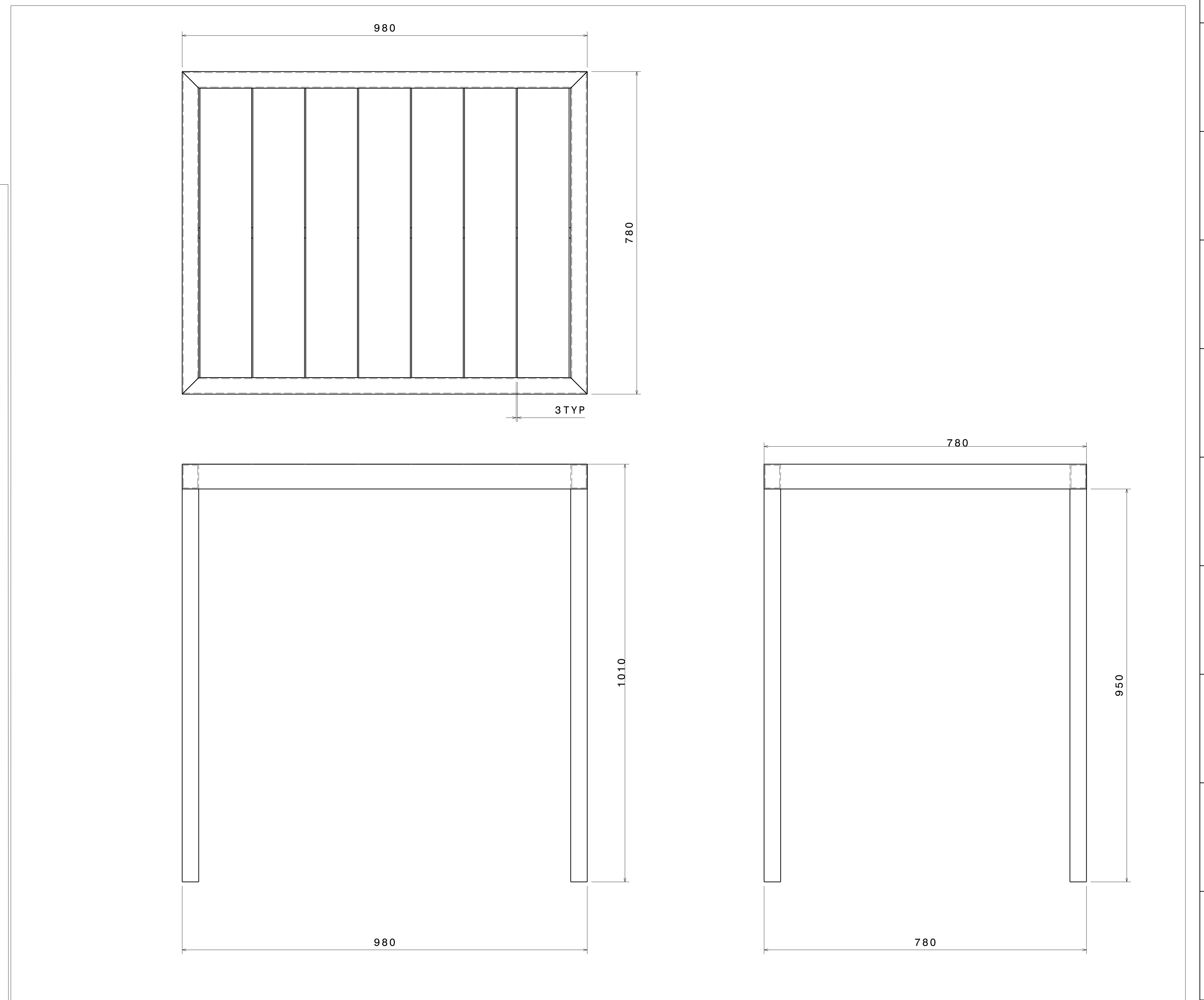

Table

UNLESS OTHERWISE SPECIFIED DIMENSION ARE IN MM VIEWS: THIRD ANGLE PROJECTION

This drawing is our property. It can't be reproduced or communicated without our written agreement.		APL APOLLO TUBES LTD.	
DRAWN BY: SB		DATE: 22NOV2020	
CHECKED BY: P2P Analysis & Solutions		DATE: 22NOV2020	
DESIGNED BY: P2P Analysis & Solutions		DATE: 22NOV2020	
DRAWING TITLE: NOV 20 15		SIZE: A0	DRAWING NUMBER: P2P NOV 20 15
SCALE: NONE		WEIGHT (kg): XXX	REV: 00
		SHEET 2 OF 3	

REV	DATE	DESCRIPTION
00	22NOV2020	INITIAL REVISION

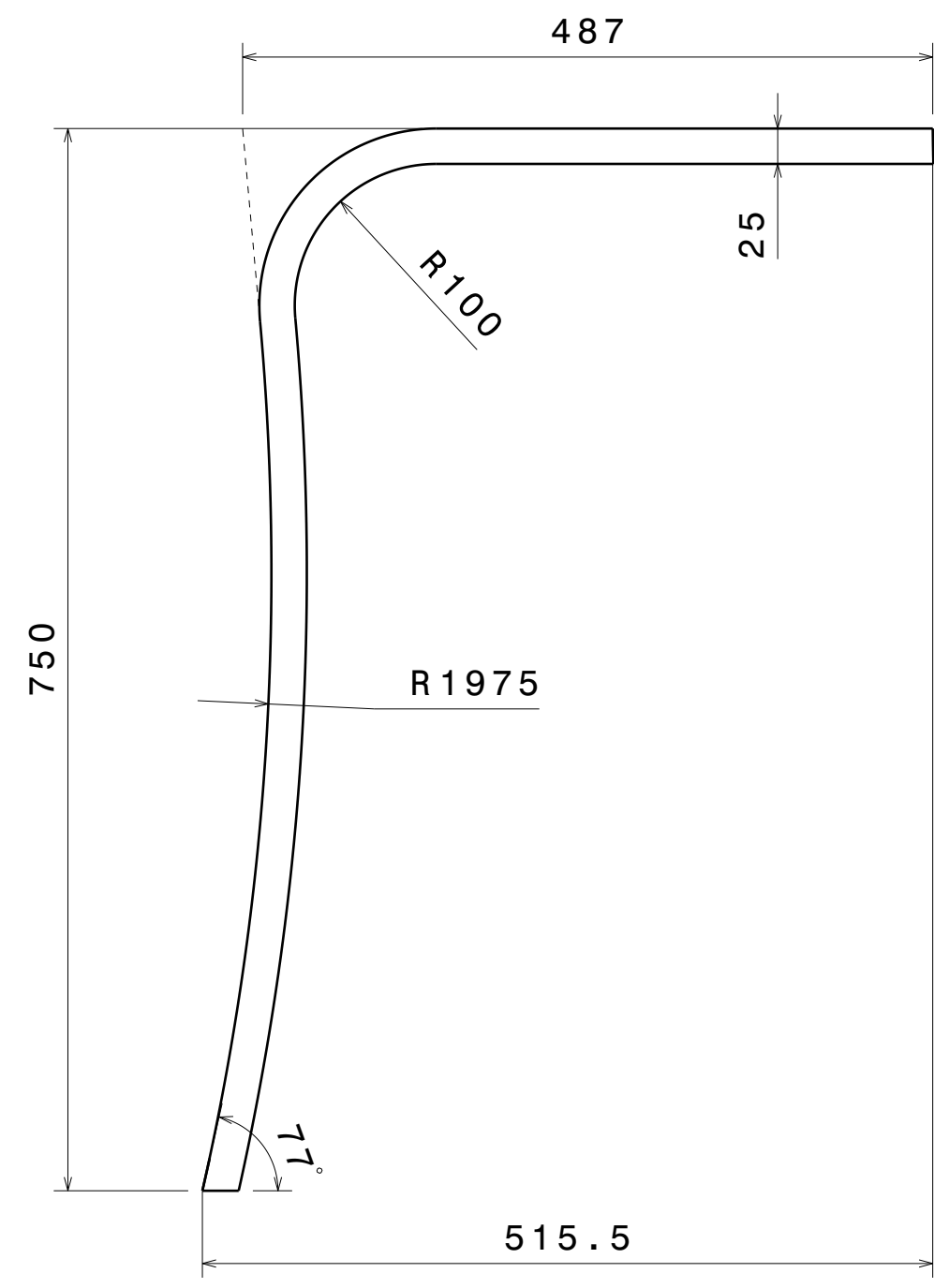

ITEM 1 DETAILS  
Rect Tube Chair & Table Frame 1

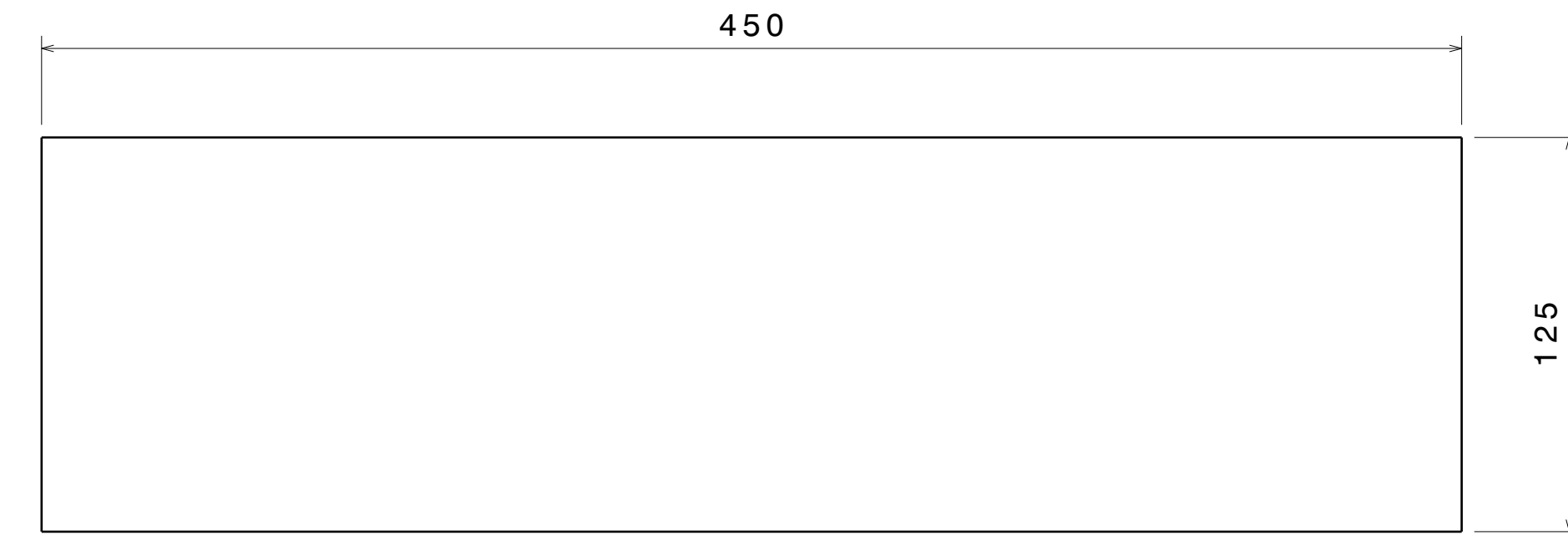

ITEM 4

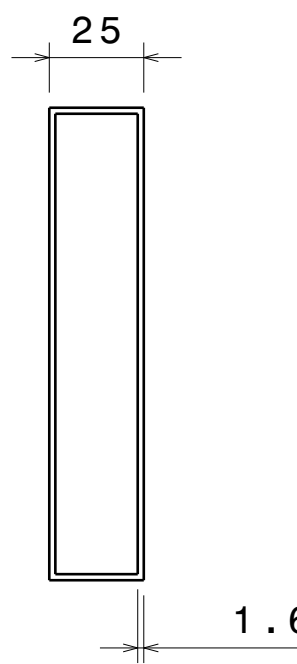

Right view  
Scale: 1:2

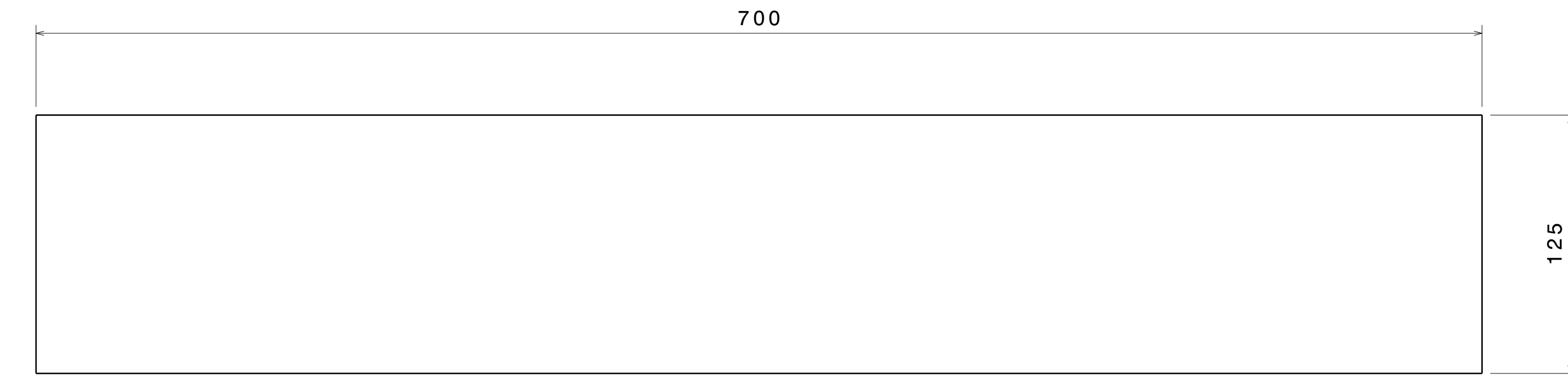

ITEM 10

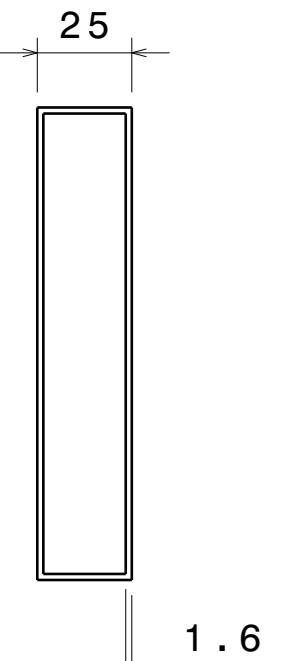

Right view  
Scale: 1:2

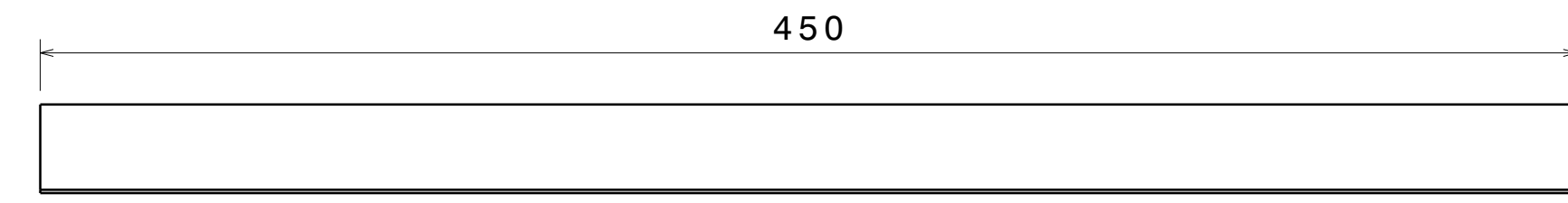

ITEM 5

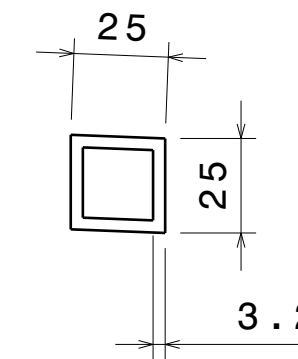

Right view  
Scale: 1:2

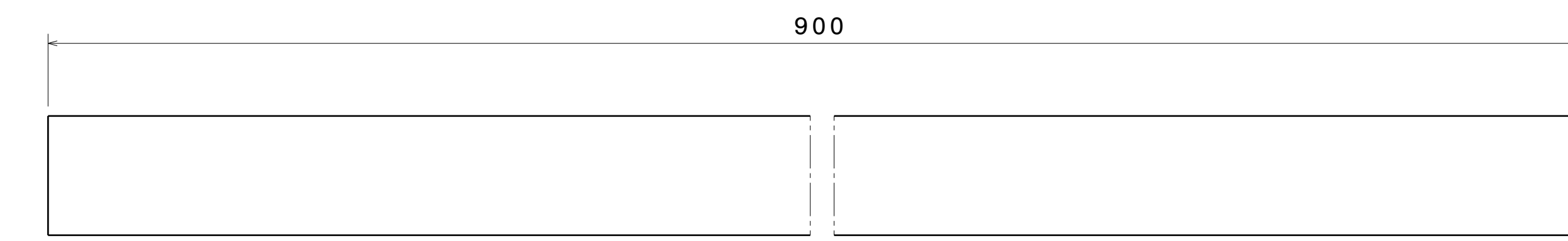

ITEM 11

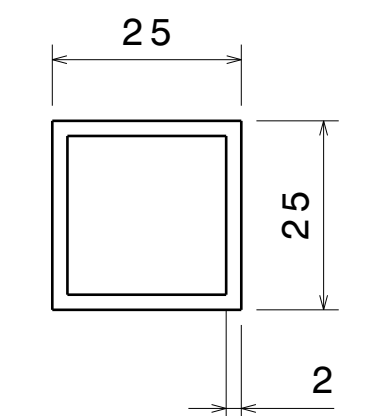

Right view  
Scale: 1:1

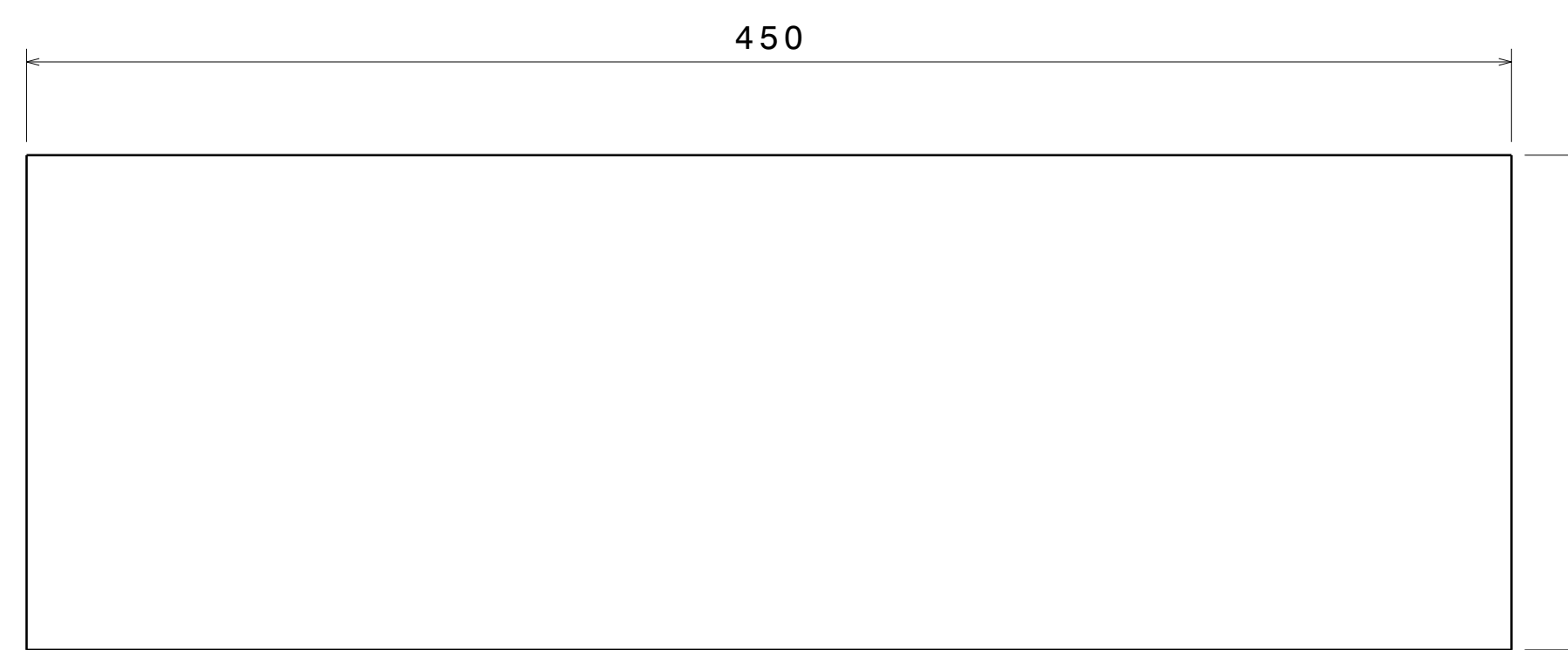

ITEM 6

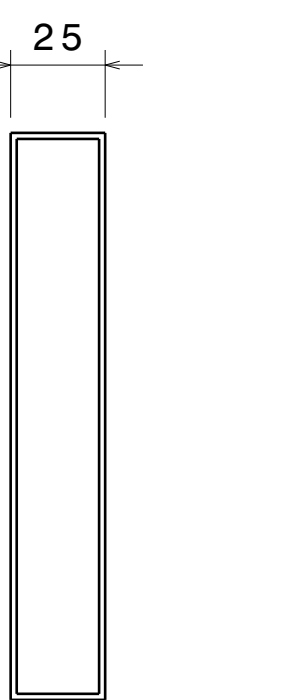

Right view  
Scale: 1:2

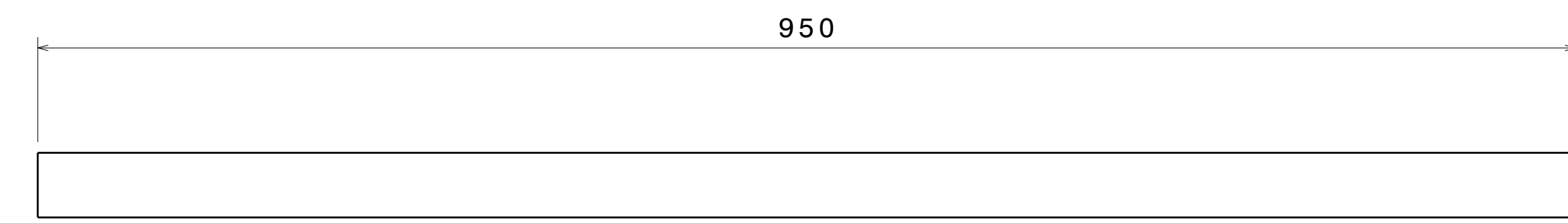

ITEM 7 DETAILS  
Sq Tube Chair & Table Frame 7

40SQ  
3.2 THK

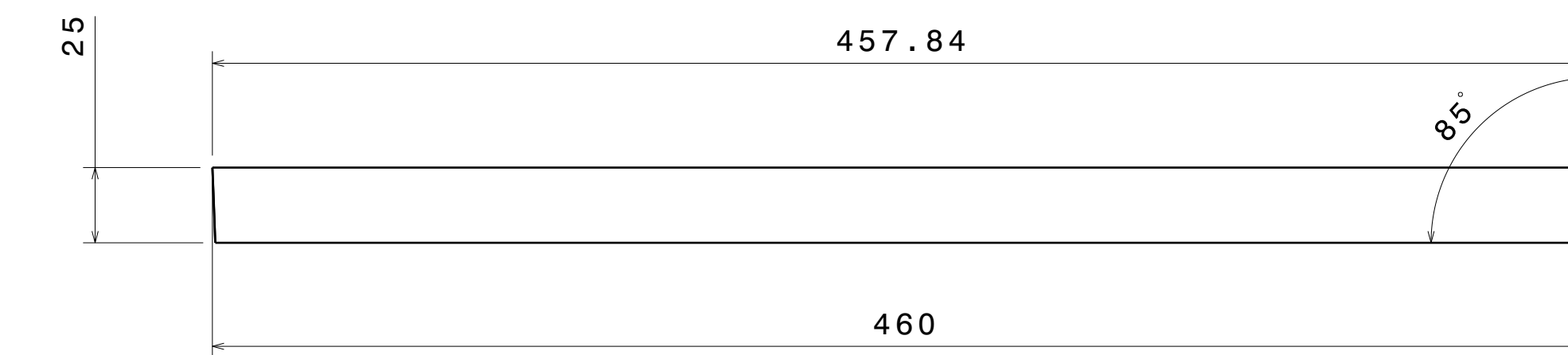

ITEM 3 DETAILS  
Rect Tube Chair & Table Frame 3

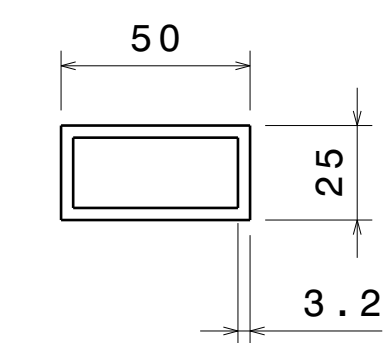

Right view  
Scale: 1:2

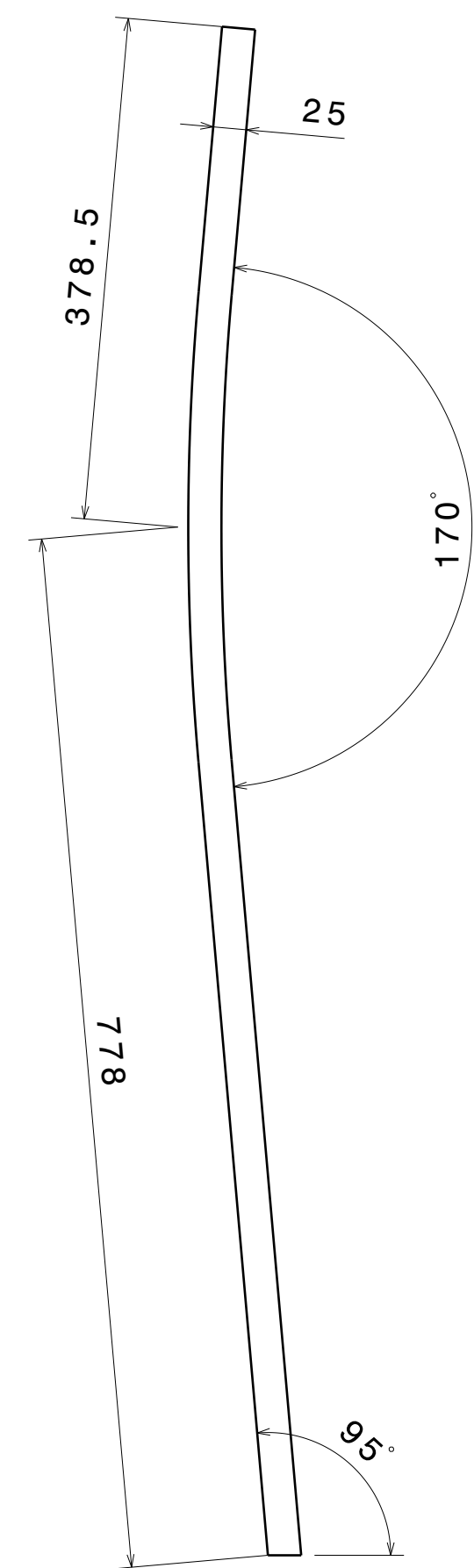

ITEM 2 DETAILS  
Rect Tube Chair & Table Frame 2

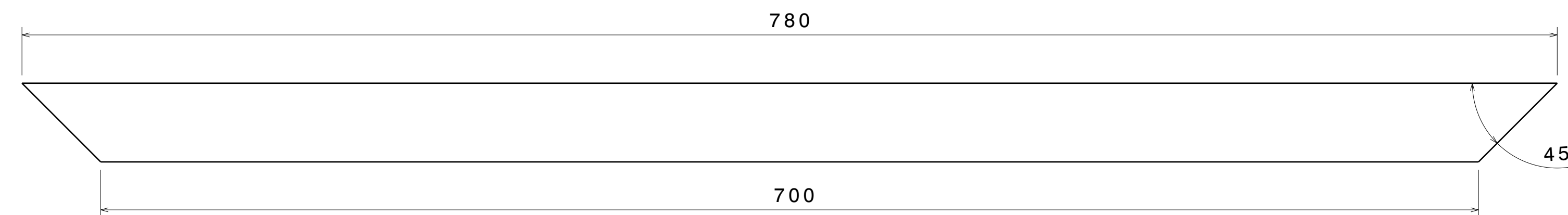

ITEM 8

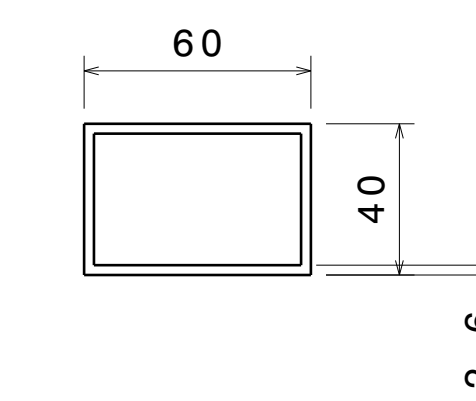

Right view  
Scale: 1:2

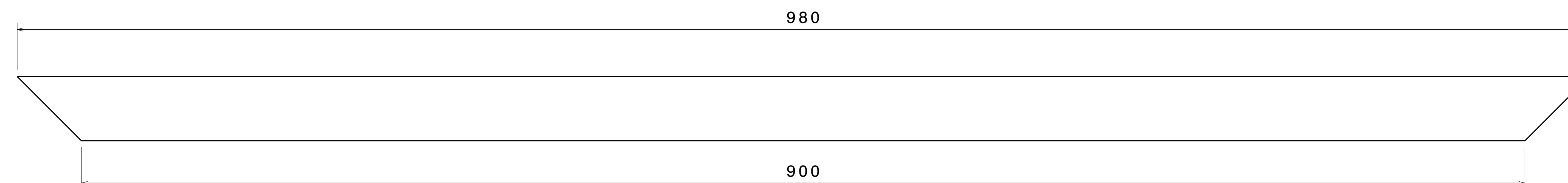

ITEM 9

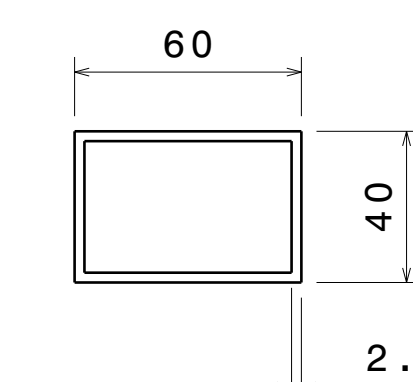

Right view  
Scale: 1:2

UNLESS OTHERWISE SPECIFIED DIMENSION ARE IN MM VIEWS: THIRD ANGLE PROJECTION

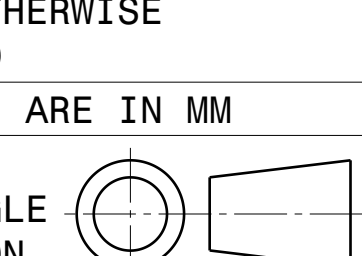

This drawing is our property. It can't be reproduced or communicated without our written agreement.

DRAWN BY	DATE
SB	22NOV2020
CHECKED BY	DATE
P2P Analysis & Solutions	22NOV2020
DESIGNED BY	DATE
P2P Analysis & Solutions	22NOV2020

APL APOLLO TUBES LTD.	
DRAWING TITLE	
NOV 20 15	
SIZE	DRAWING NUMBER
A0	P2P NOV 20 15
SCALE	WEIGHT (kg)
NONE	XXX
SHEET 3 OF 3	