

REV/DATE	DESCRIPTION
00 / 11NOV2020	INITIAL REVISION

NOTES:

- (⊥) ALL VERTICAL SUPPORTS ARE PERPENDICULAR.
- FLATNESS OF .5MM IS APPLIED BY DEFAULT.
- ⊲ WELD BEAD OF 2MM RADIUS IS FOLLOWED.
- ▽ SURFACE FINISH MEDIUM TO SMOOTH IS USED.
- ALL TUBES ARE AS PER APL APOLLO STANDARD. CHANGES MAY EFFECT THE LOAD CAPACITY.
- ALL HORIZONTAL AND VERTICAL TUBES ARE PERPENDICULAR TO EACH OTHER WITH ±1 DEG.
- FINE WELDING IS REQUIRED AS PER MENTIONED DETAILS AND FINISHING.
- HIGHER CURRENT WELDING MAY AFFECT THE BRITTLENESS OF MATERIAL WHICH LATER MAY RAISE TO WEAKENING OF STRUCTURE.
- FABRICATORS ARE ALLOWED TO USE FITTINGS/FRAMES/SUPPORTS AS NEEDED AND THE SAME MUST BE COMMUNICATED BACK TO ENGINEERING TEAM.
- BOP COMPONENT WEIGHTS ARE FOR REFERENCE ONLY AND SUBJECTED TO CHANGE PER PURCHASED COMPONENTS.

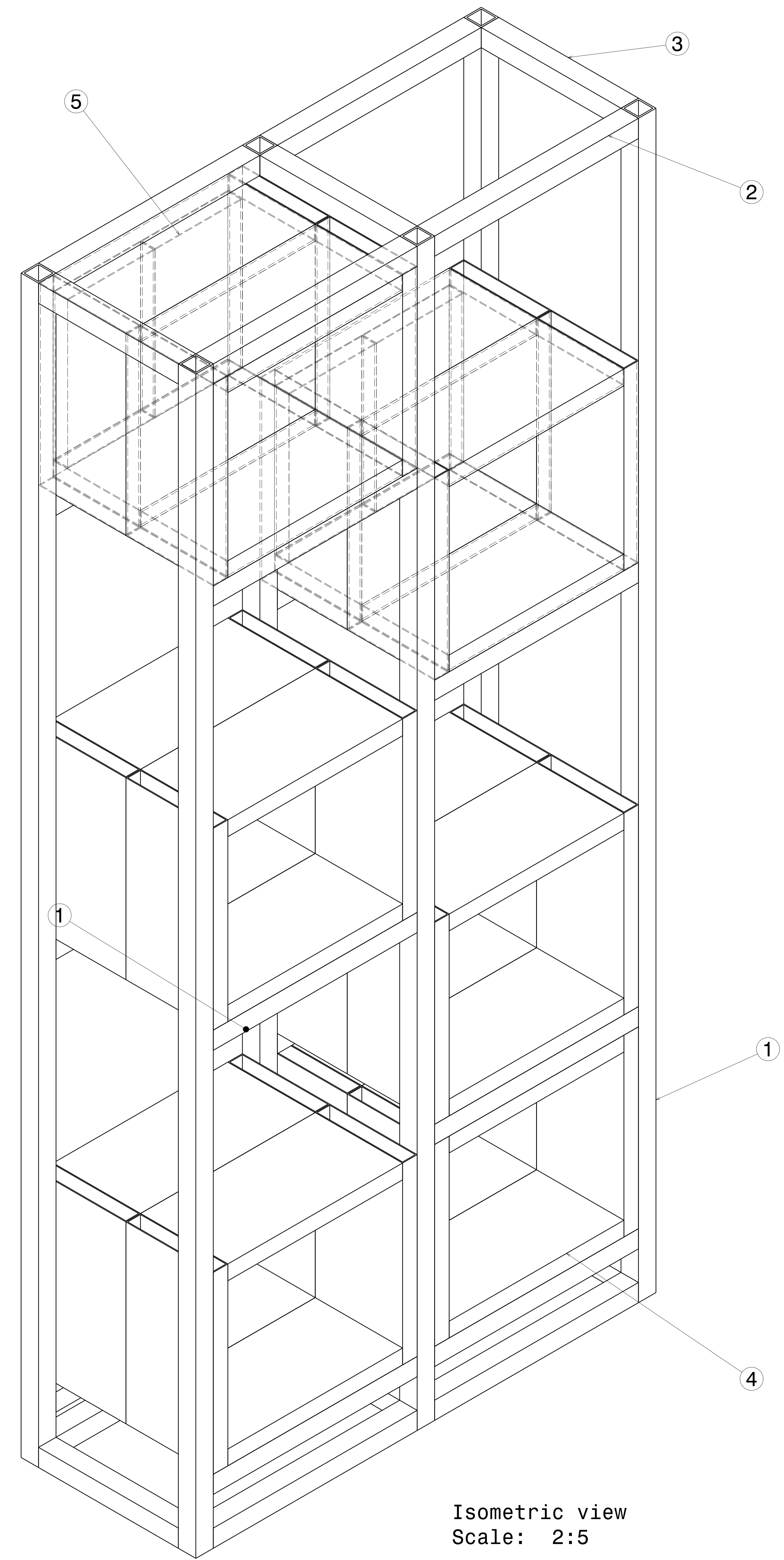

Isometric view
Scale: 2:5

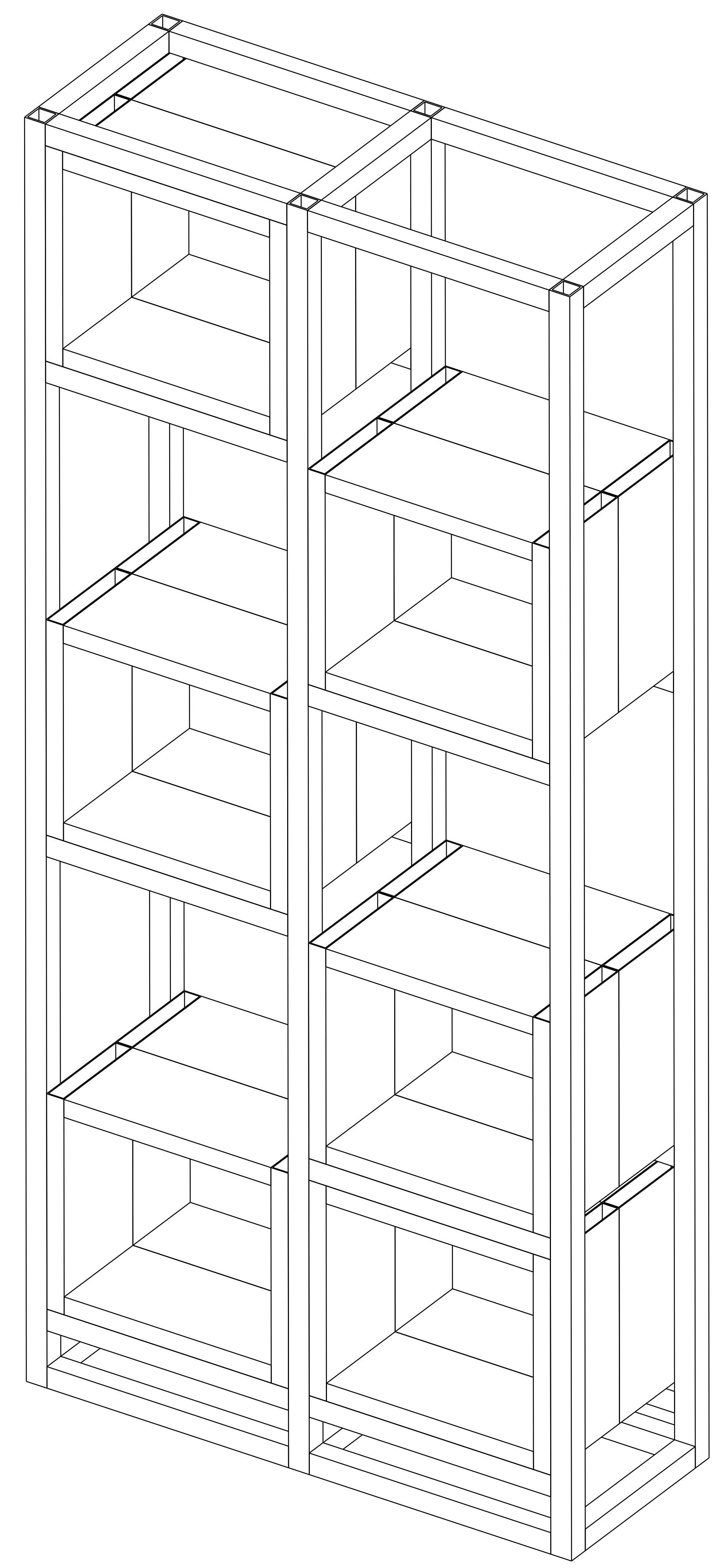

Isometric view
Scale: 3:10

ITEM NO.	PART NUMBER	DESCRIPTION	QTY.	Wt (kg) /Each
5	PLANK 2	150 X 25 X 1.6 X 250	16	1.08
4	PLANK 1	150 X 25 X 1.6 X 300	48	1.3
3	SHS 3	30 X 30 X 1.6 X 240	6	0.34
2	SHS 2	30 X 30 X 1.6 X 350	20	0.5
1	SHS 1	30 X 30 X 2.6 X 1760	6	3.94

This drawing is our property. It can't be reproduced or communicated without our written agreement.		APL APOLLO TUBES LTD. 	
DRAWN BY SB		DATE 11NOV2020	
CHECKED BY P2P Analysis & Solutions		DATE 11NOV2020	
DESIGNED BY P2P Analysis & Solutions		DATE 11NOV2020	
DRAWING TITLE NOV 20 17		REV 00	
SIZE A0		DRAWING NUMBER P2P NOV 20 17	
SCALE As Indicated		WEIGHT (kg) 0kg	
		SHEET 1 OF 3	

UNLESS OTHERWISE SPECIFIED DIMENSION ARE IN MM
VIEWS: THIRD ANGLE PROJECTION

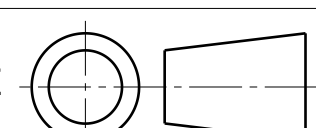

REV	DATE	DESCRIPTION
00	11NOV2020	INITIAL REVISION

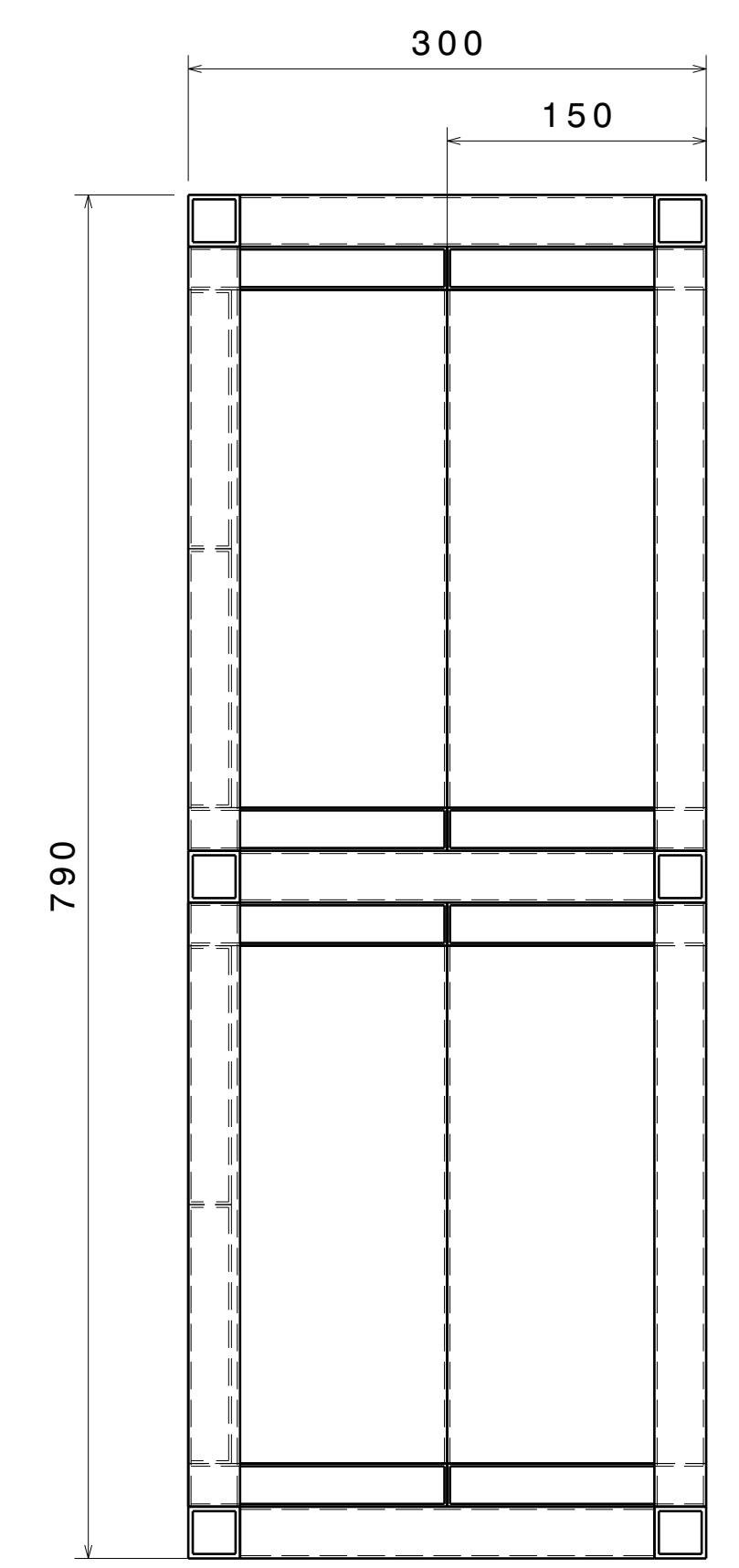

Top view
Scale: 1:4

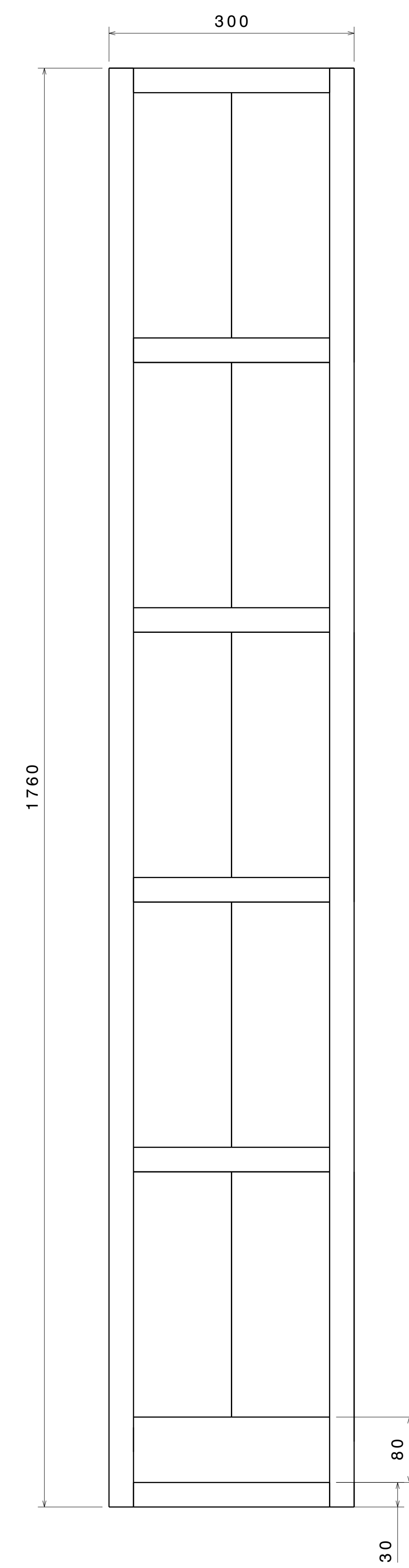

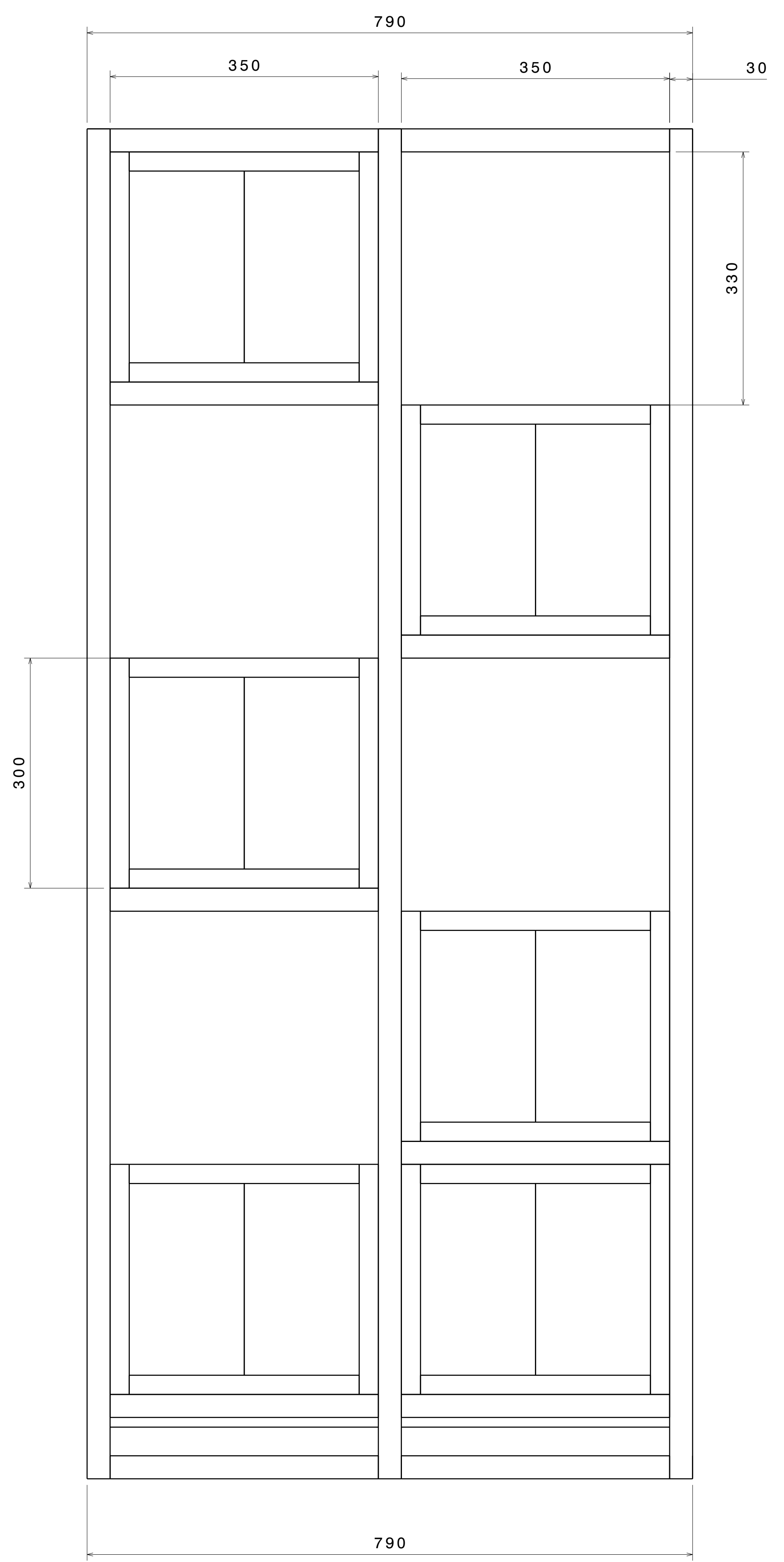

Front view
Scale: 1:4

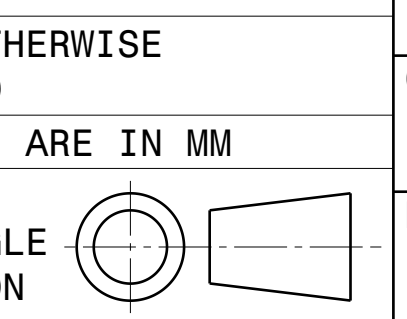

Right view
Scale: 1:4

UNLESS OTHERWISE SPECIFIED DIMENSION ARE IN MM
VIEWS: THIRD ANGLE PROJECTION



This drawing is our property. It can't be reproduced or communicated without our written agreement.		APL APOLLO TUBES LTD. 	
DRAWN BY SB		DRAWING TITLE NOV 20 17	
CHECKED BY P2P Analysis & Solutions		DATE 11NOV2020	
DESIGNED BY P2P Analysis & Solutions		DATE 11NOV2020	
SCALE NONE	WEIGHT (kg) XXX	REV 00	SHEET 2 OF 3

REV	DATE	DESCRIPTION
00	11NOV2020	INITIAL REVISION

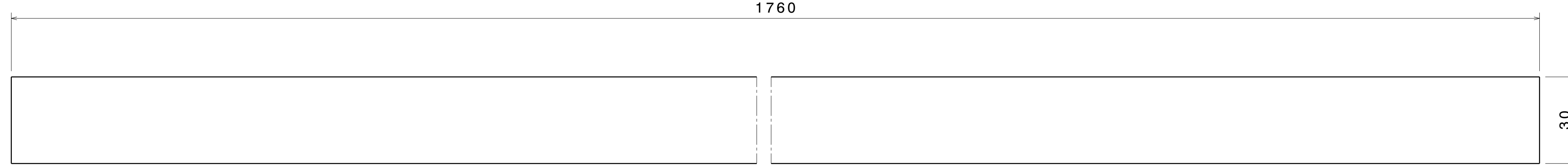

ITEM 1

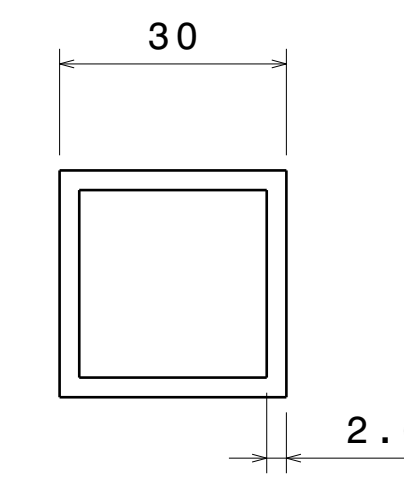

Right view
Scale: 1:1

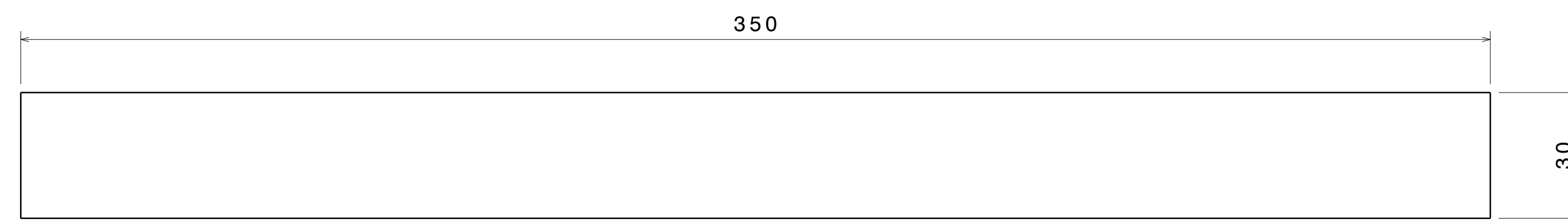

ITEM 2

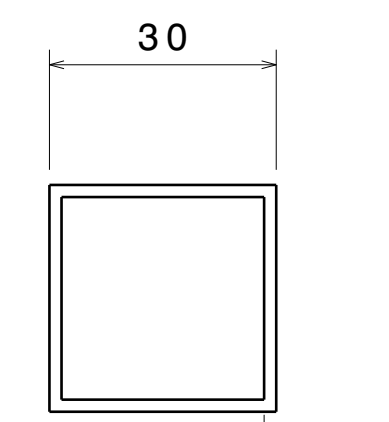

Right view
Scale: 1:1

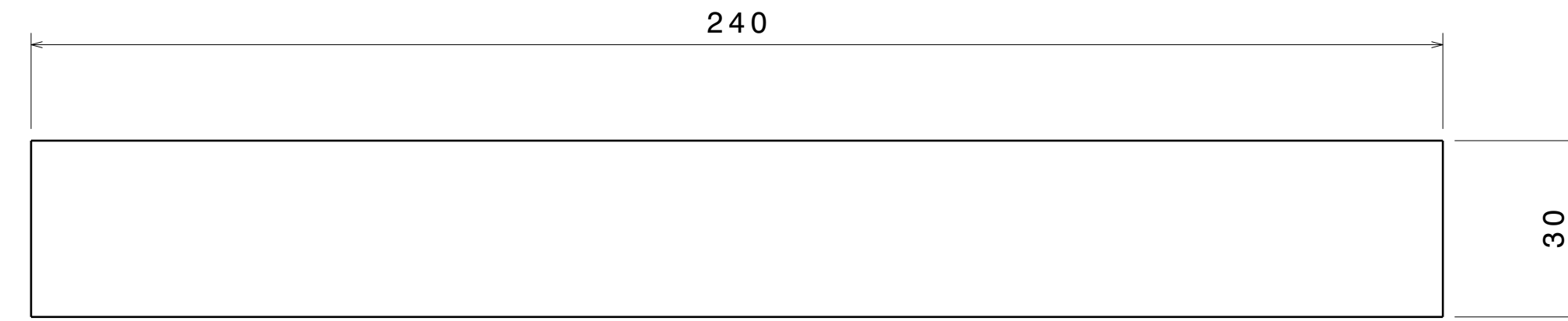

ITEM 3

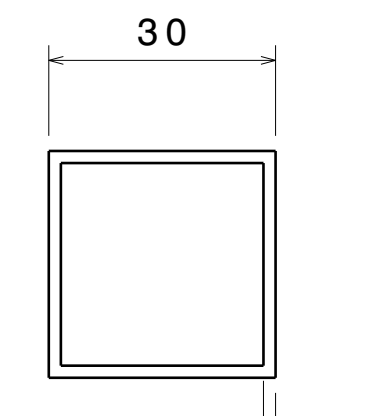

Right view
Scale: 1:1

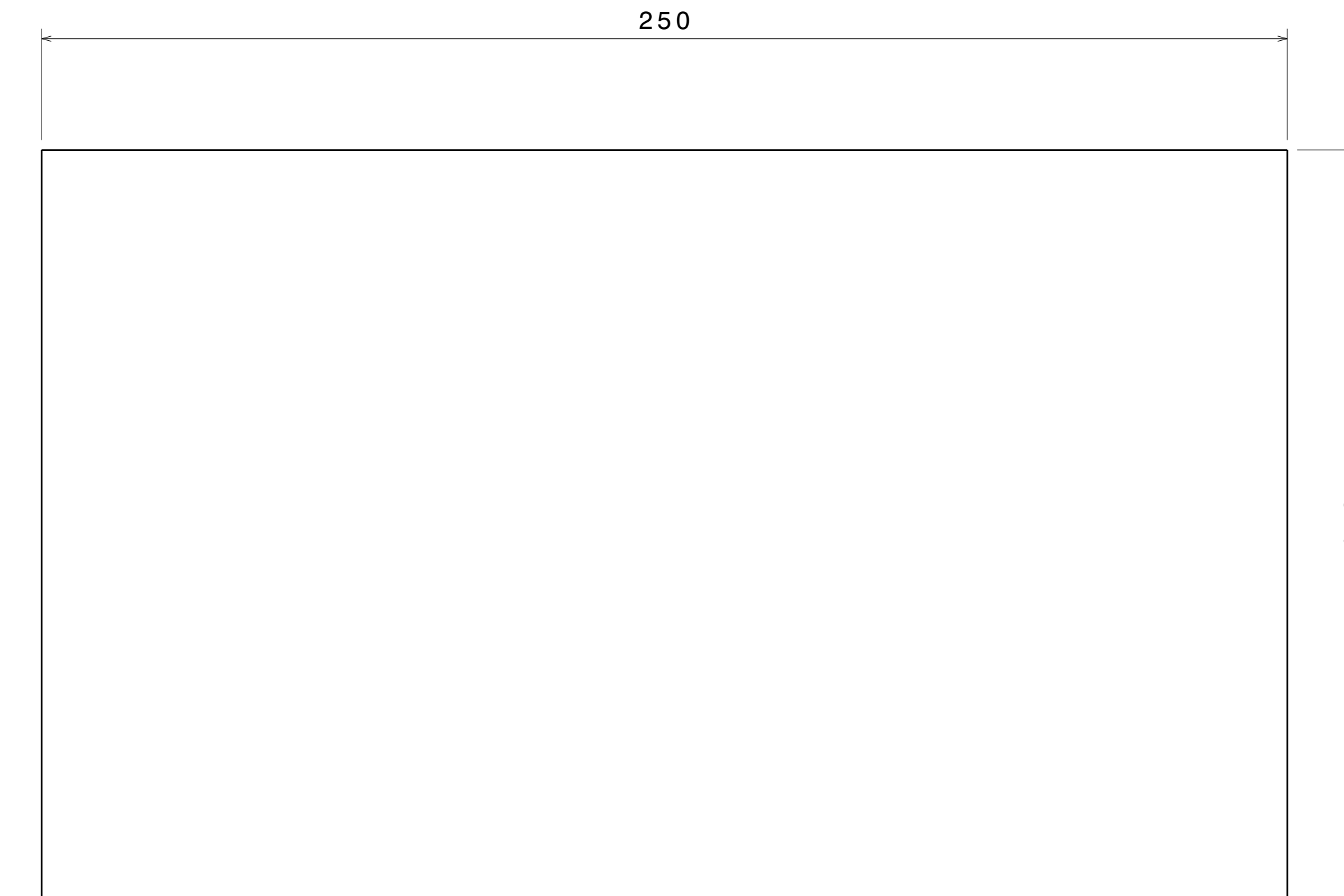

ITEM 5

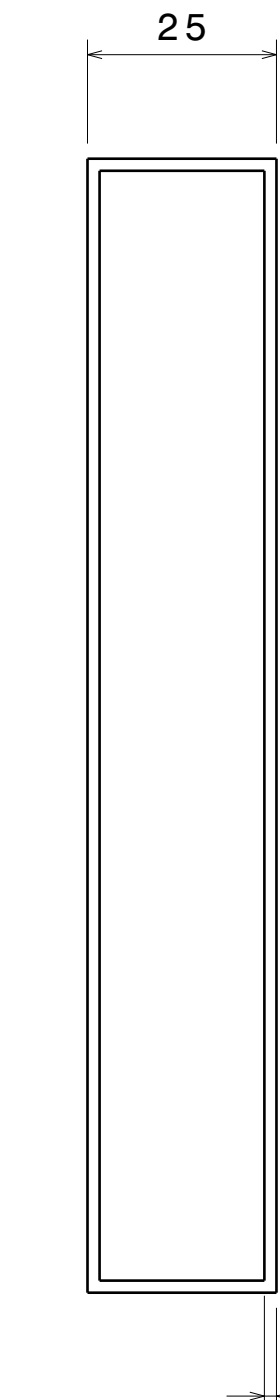

Right view
Scale: 1:1

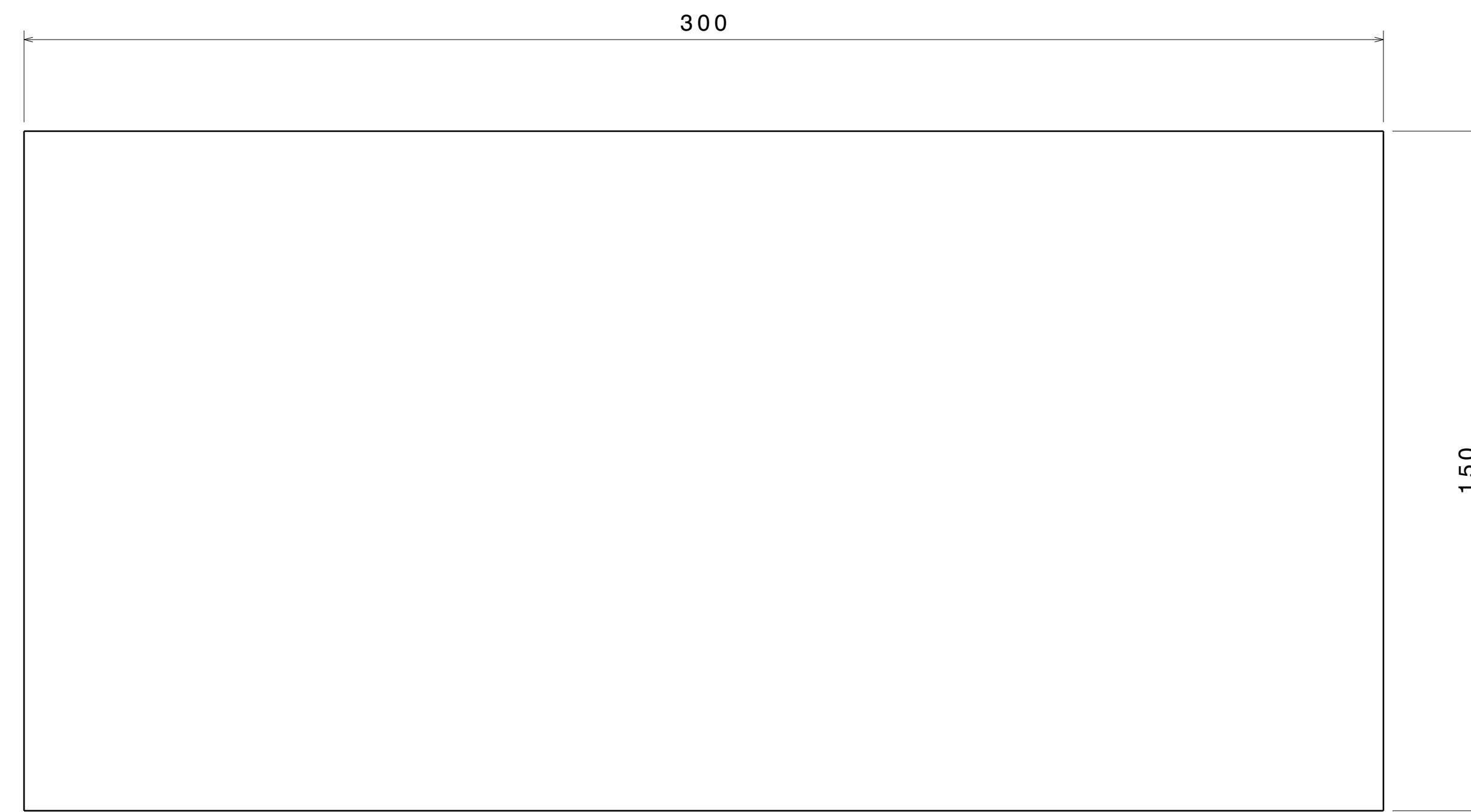

ITEM 4

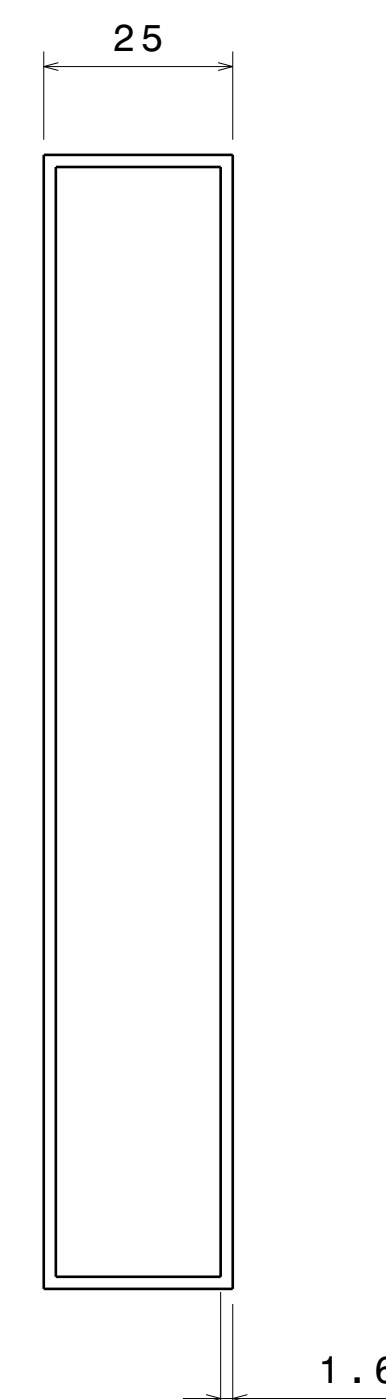

Right view
Scale: 1:1

UNLESS OTHERWISE SPECIFIED DIMENSION ARE IN MM
VIEWS: THIRD ANGLE PROJECTION

This drawing is our property. It can't be reproduced or communicated without our written agreement.		APL APOLLO TUBES LTD.	
DRAWN BY SB		DATE 11NOV2020	
CHECKED BY P2P Analysis & Solutions		DATE 11NOV2020	
DESIGNED BY P2P Analysis & Solutions		DATE 11NOV2020	
DRAWING TITLE NOV 20 17		SIZE A0	REV 00
SCALE NONE		WEIGHT (kg) XXX	SHEET 3 OF 3