

REV	DATE	DESCRIPTION
00	10OCT2020	INITIAL REVISION

- NOTES:
- (⊥) ALL VERTICAL SUPPORTS ARE PERPENDICULAR.
 - FLATNESS OF .5MM IS APPLIED BY DEFAULT.
 - ⊲ WELD BEAD OF 2MM RADIUS IS FOLLOWED.
 - ▽▽ SURFACE FINISH MEDIUM TO SMOOTH IS USED.
 - ALL TUBES ARE AS PER APL APOLLO STANDARD. CHANGES MAY EFFECT THE LOAD CAPACITY.
 - ALL HORIZONTAL AND VERTICAL TUBES ARE PERPENDICULAR TO EACH OTHER WITH ±1 DEG.
 - FINE WELDNG IS REQUIRED AS PER MENTIONED DETAILS AND FINISHING.
 - HIGHER CURRENT WELDING MAY AFFECT THE BRITTLNESS OF MATERIAL WHICH LATER MAY RAISE TO WEAKENING OF STRUCTURE.
 - FABRICATORS ARE ALLOWED TO USE FITTINGS/FRAMES/SUPPORTS AS NEEDED AND THE SAME MUST BE COMMUNICATED BACK TO ENGINEERING TEAM.
 - BOP COMPONENT WEIGHTS ARE FOR REFERENCE ONLY AND SUBJECTED TO CHANGE PER PURCHASED COMPONENTS.

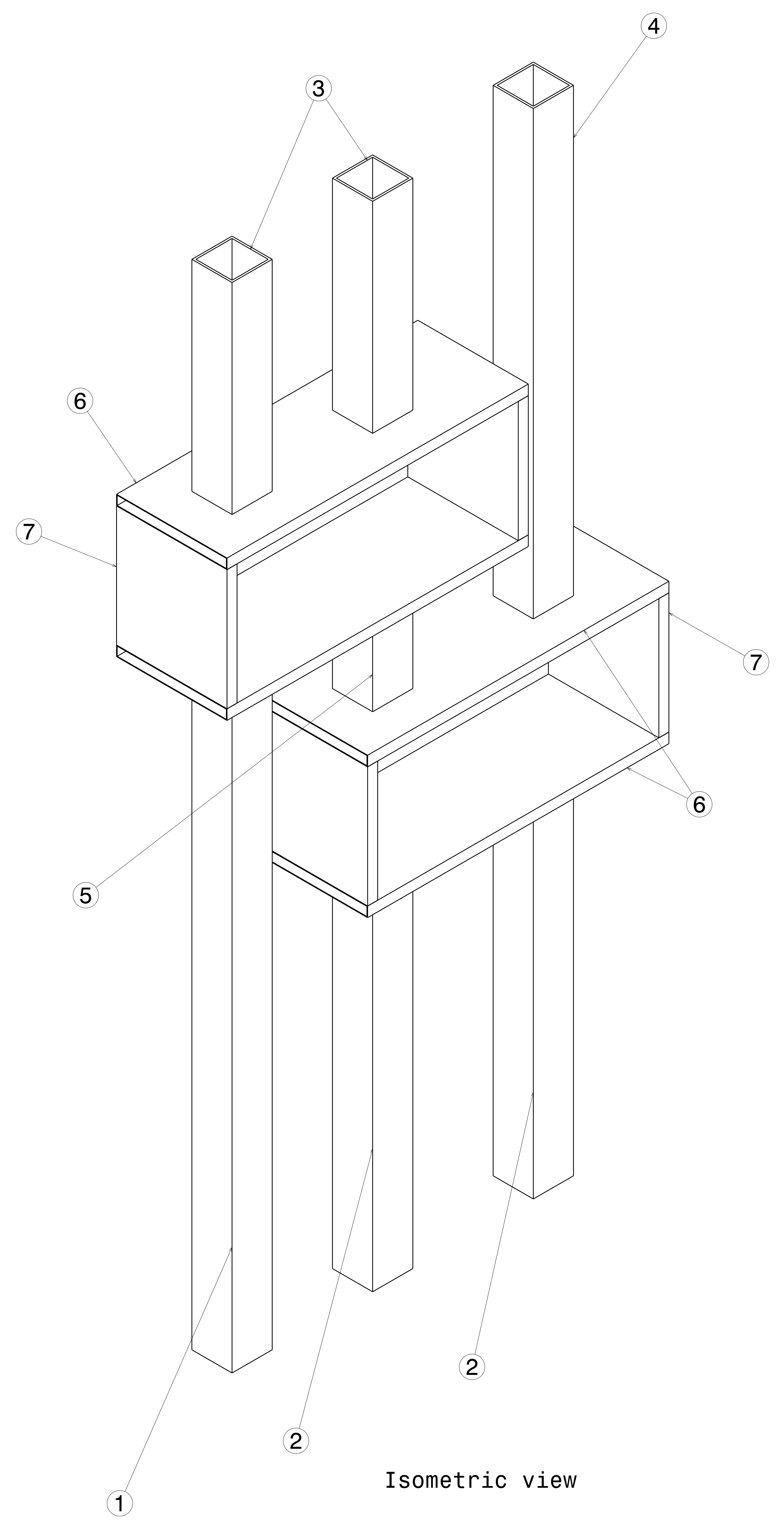

ITEM NO.	PART NUMBER	DESCRIPTION	QTY.	Wt (kg)/Each
7	Wall Partition Plank 2	275 X 25 X 1.6 X 300	4	2.24
6	Wall Partition Plank 1	275 X 25 X 1.6 X 750	4	5.6
5	Wall Partition SQ Frame 5	100 X 100 X 5 X 250	1	3.75
4	Wall Partition SQ Frame 4	100 X 100 X 5 X 1100	1	16.4
3	Wall Partition SQ Frame 3	100 X 100 X 5 X 500	2	7.5
2	Wall Partition SQ Frame 2	100 X 100 X 5 X 900	2	13.44
1	Wall Partition SQ Frame 1	100 X 100 X 5 X 1500	1	22.4

This drawing is our property. It can't be reproduced or communicated without our written agreement.		APL APOLLO TUBES LTD.	
DRAWN BY		DATE	
SB		10OCT2020	
CHECKED BY		DATE	
P2P Analysis & Solutions		10OCT2020	
DESIGNED BY		DATE	
P2P Analysis & Solutions		10OCT2020	
DRAWING TITLE		Wall Partition Oct 10	
SIZE	DRAWING NUMBER	REV	
A0	P2P Wall Partition Oct 10	00	
SCALE	WEIGHT(kg)	Okg	SHEET 1 OF 3
As Indicated			

UNLESS OTHERWISE SPECIFIED DIMENSION ARE IN MM
 VIEWS: THIRD ANGLE PROJECTION

REV	DATE	DESCRIPTION
00	10OCT2020	INITIAL REVISION

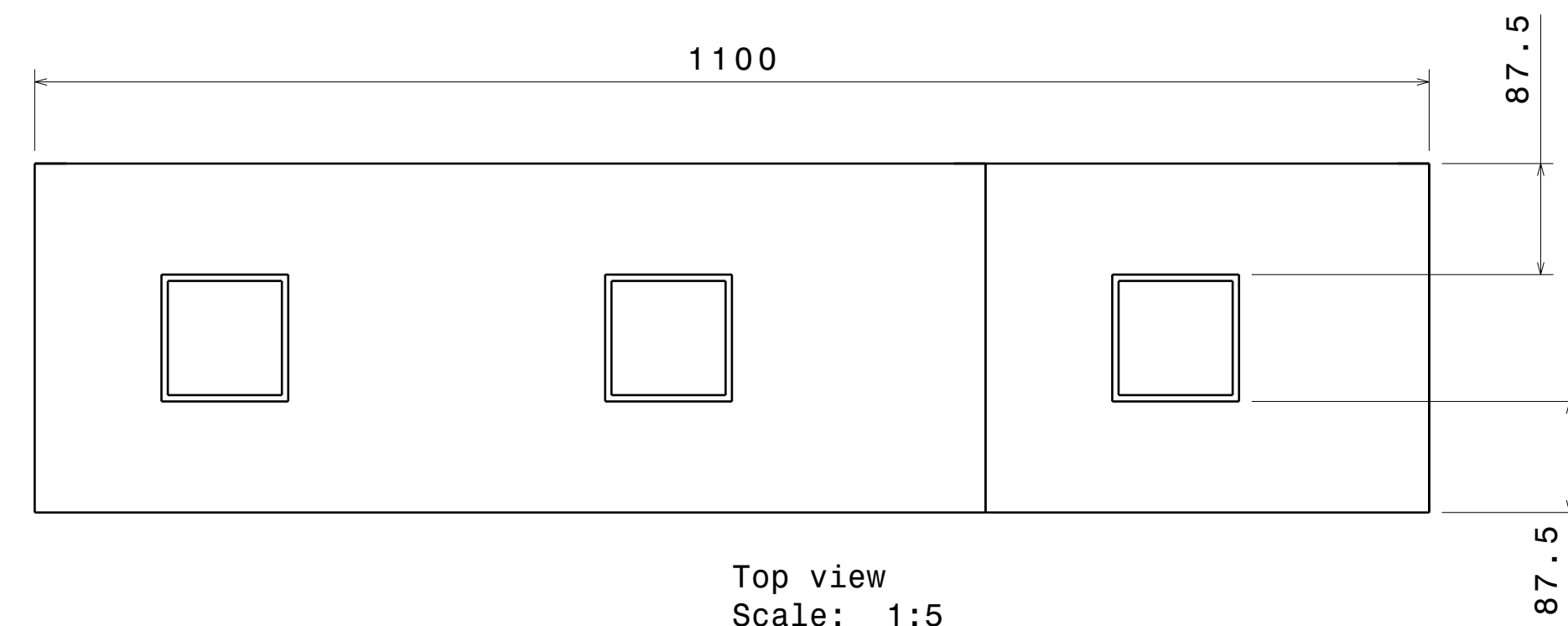

Top view
Scale: 1:5

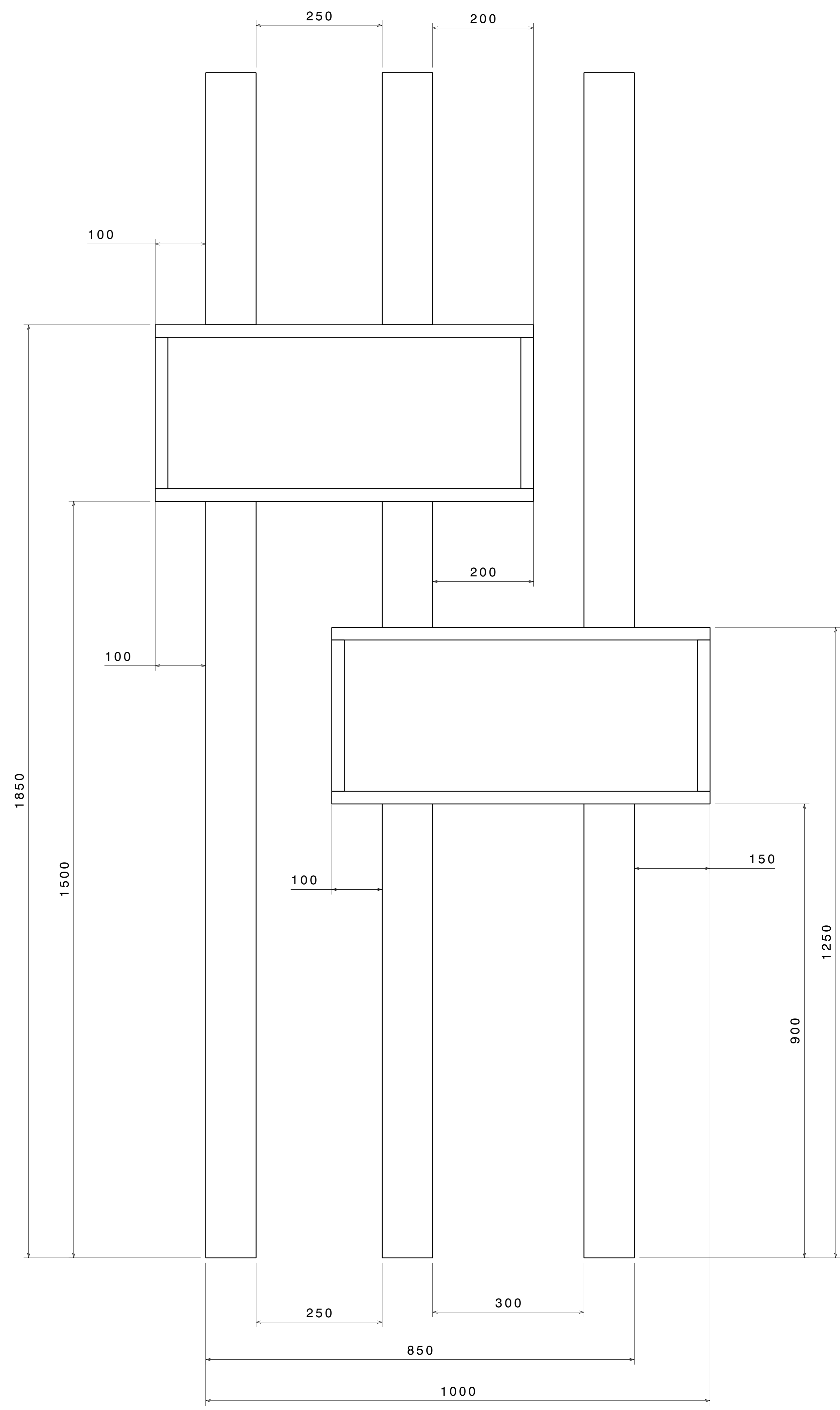

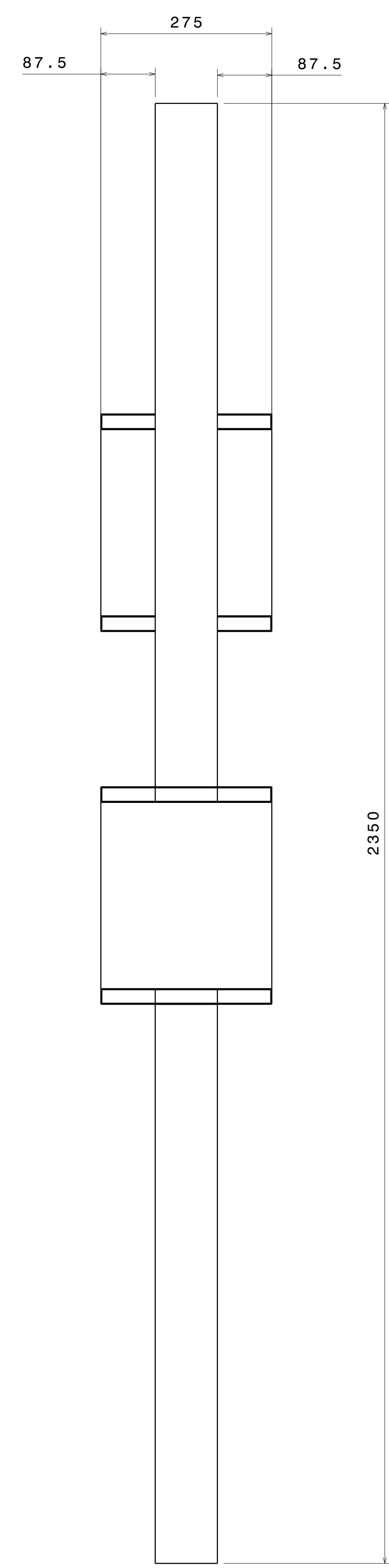

Front view
Scale: 1:5

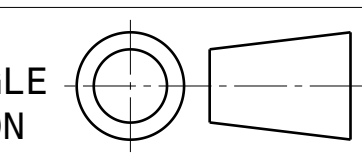

Right view
Scale: 1:5

UNLESS OTHERWISE SPECIFIED DIMENSION ARE IN MM
VIEWS: THIRD ANGLE PROJECTION



This drawing is our property. It can't be reproduced or communicated without our written agreement.		APL APOLLO TUBES LTD. 	
DRAWN BY SB		DATE 10OCT2020	
CHECKED BY P2P Analysis & Solutions		DATE 10OCT2020	
DESIGNED BY P2P Analysis & Solutions		DATE 10OCT2020	
DRAWING TITLE Wall Partition Oct 10		SIZE A0	DRAWING NUMBER P2P Wall Partition Oct 10
SCALE NONE		WEIGHT(kg) XXX	REV 00
		SHEET 2 OF 3	

REV	DATE	DESCRIPTION
00	10OCT2020	INITIAL REVISION

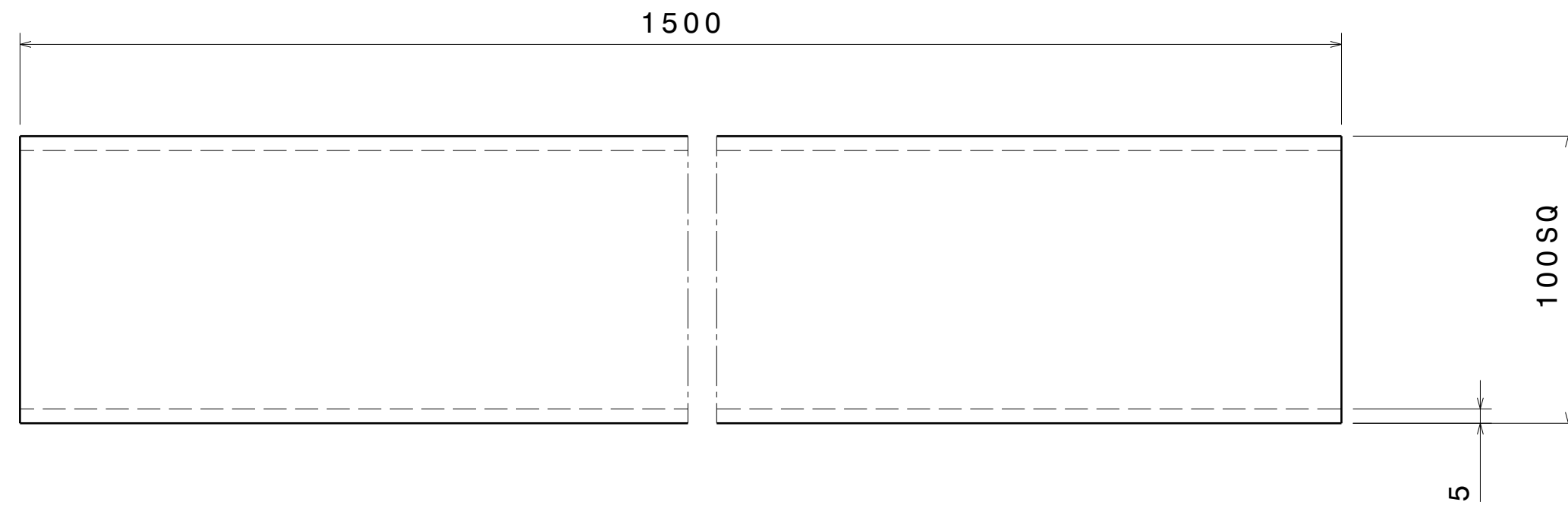

ITEM 1

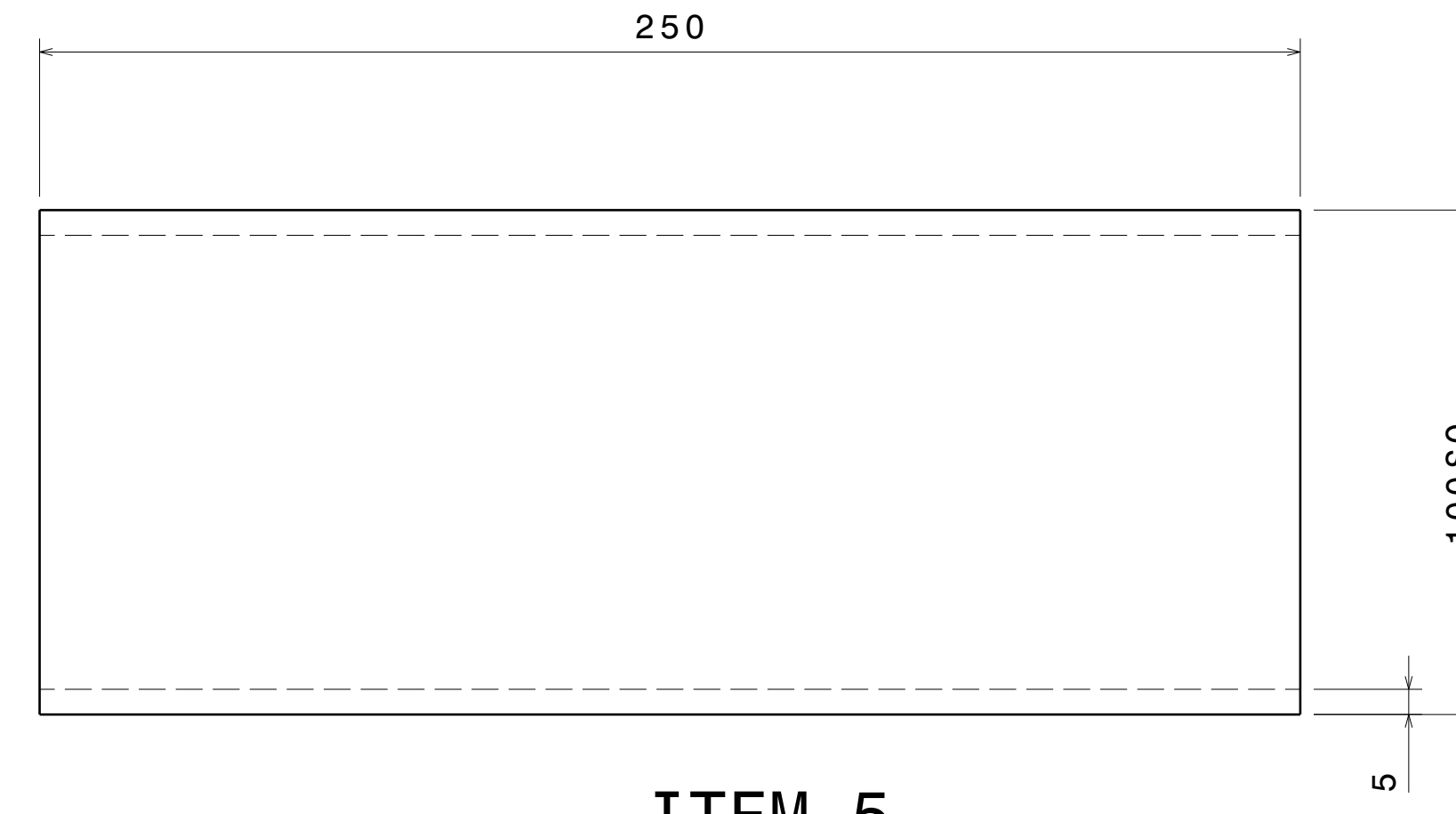

ITEM 5

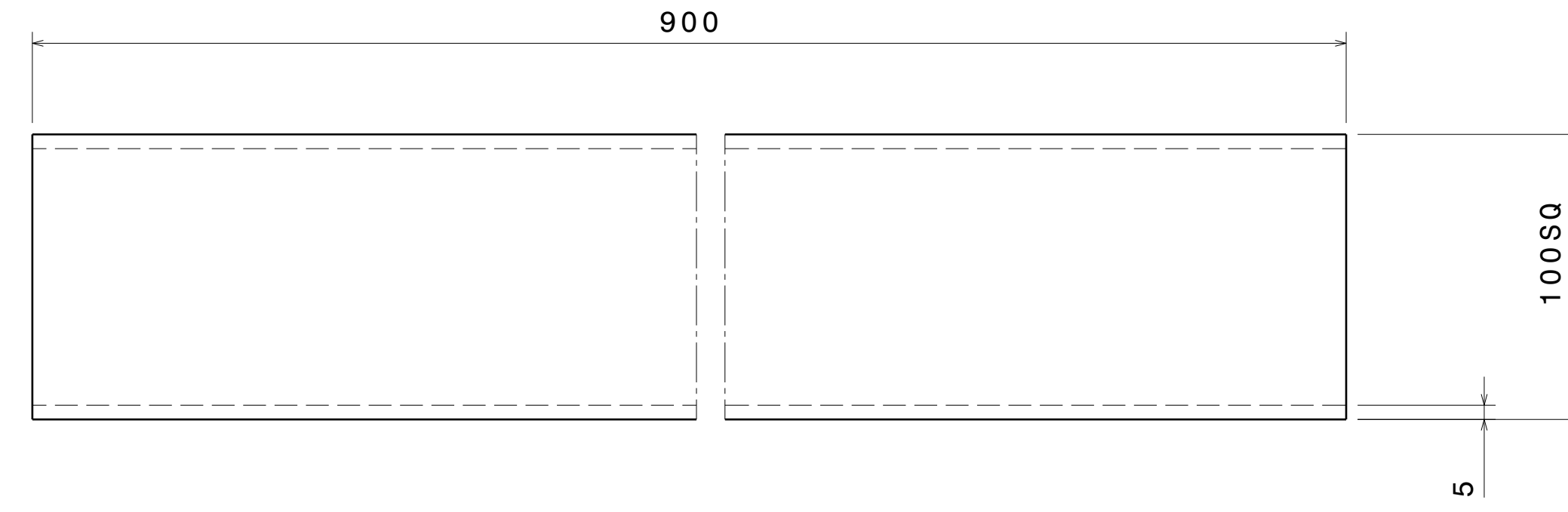

ITEM 2



ITEM 6

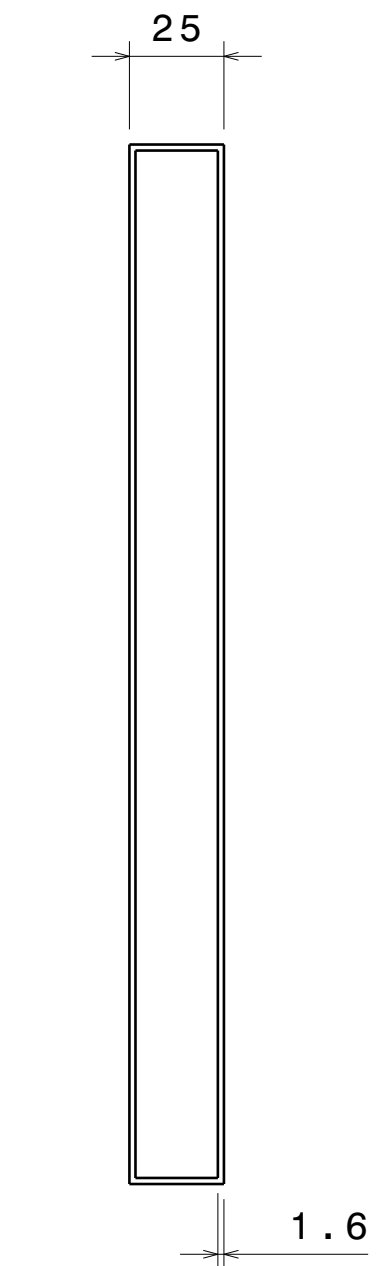

Right view
Scale: 1:2

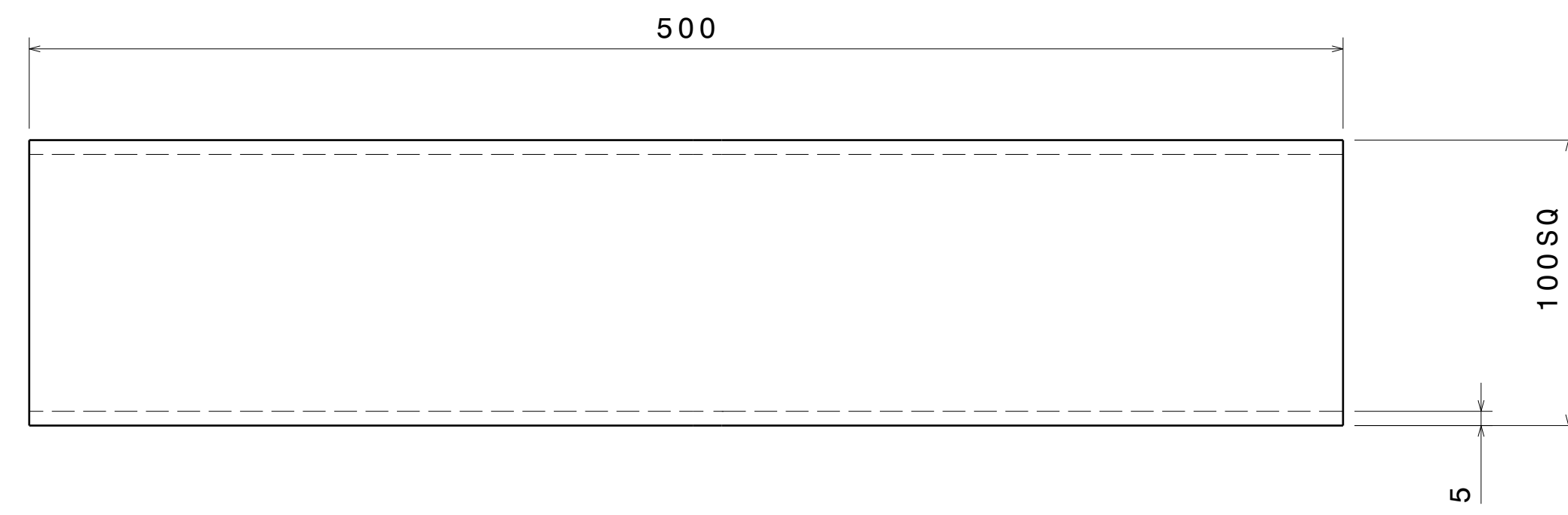

ITEM 3

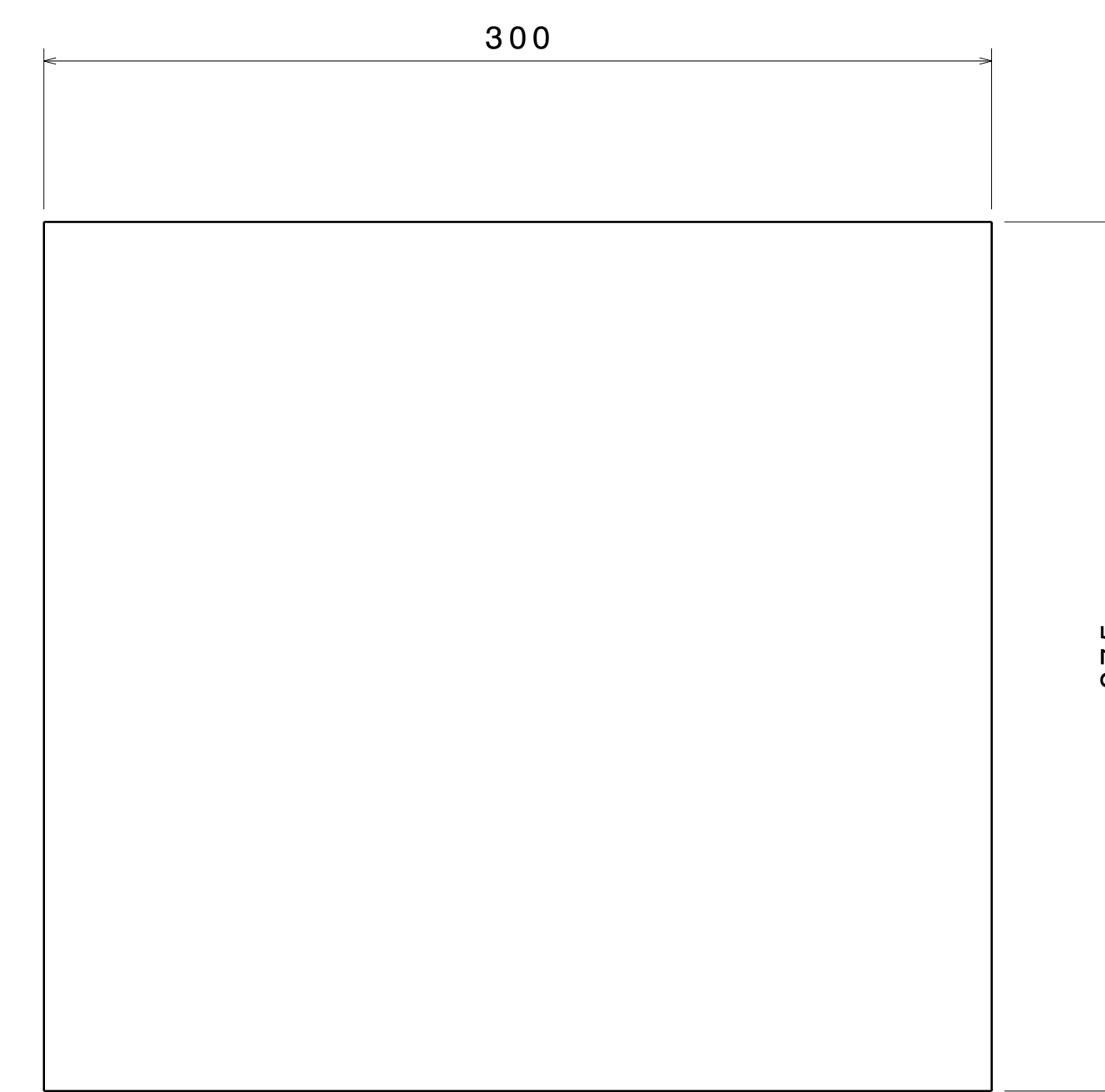

ITEM 7

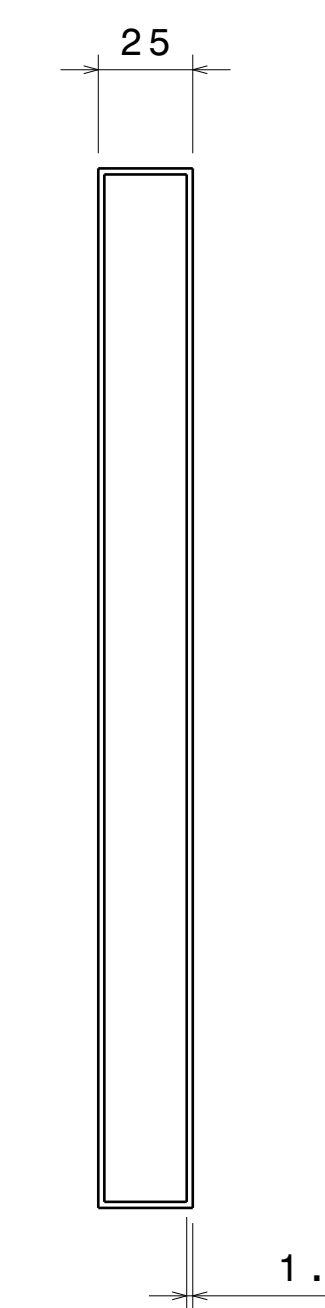

Right view
Scale: 1:2

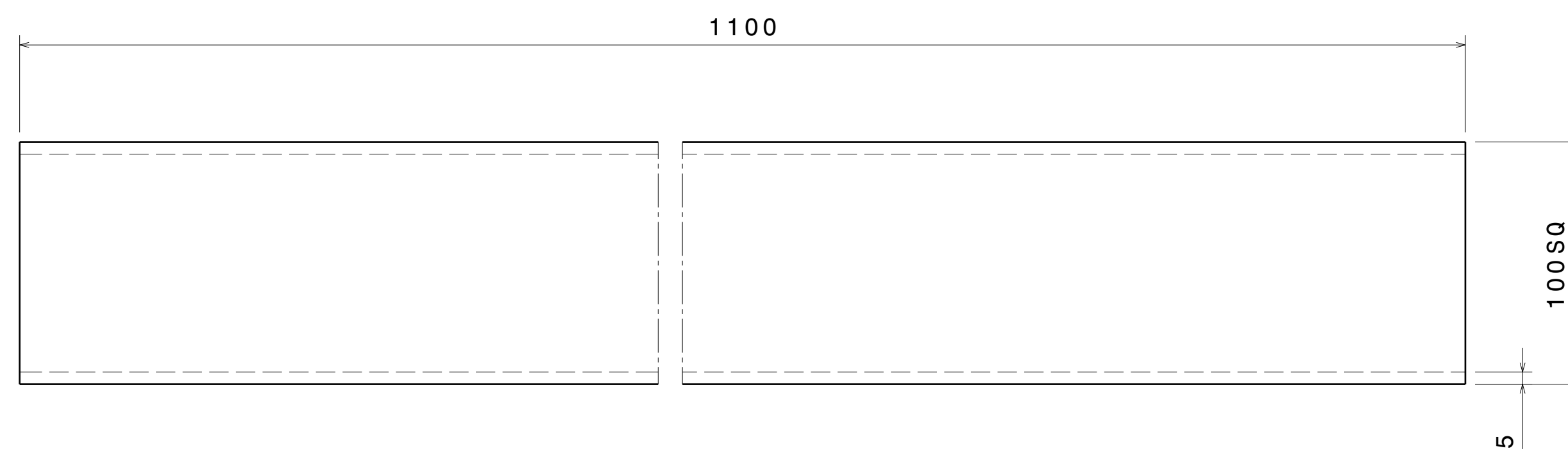

ITEM 4

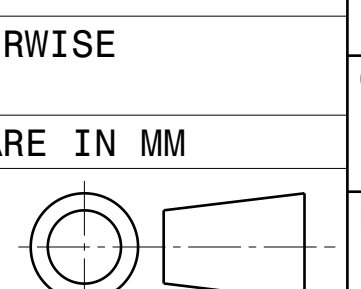
This drawing is our property. It can't be reproduced or communicated without our written agreement.		APL APOLLO TUBES LTD. 	
DRAWN BY SB		DATE 10OCT2020	
CHECKED BY P2P Analysis & Solutions		DATE 10OCT2020	
DESIGNED BY P2P Analysis & Solutions		DATE 10OCT2020	
UNLESS OTHERWISE SPECIFIED DIMENSION ARE IN MM VIEWS: THIRD ANGLE PROJECTION 		DRAWING TITLE Wall Partition Oct 10	
		SIZE A0	DRAWING NUMBER P2P Wall Partition Oct 10
		SCALE NONE	WEIGHT(kg) XXX
		REV 00	
		SHEET 3 OF 3	