

REV/DATE	DESCRIPTION
A / 2/28/2020	INITIAL REVISION

NOTES:

- (⊥) ALL VERTICAL SUPPORTS ARE PERPENDICULAR.
- FLATNESS OF .5MM IS APPLIED BY DEFAULT.
- ⊥ WELD BEAD OF 2MM RADIUS IS FOLLOWED.
- ▽ SURFACE FINISH MEDIUM TO SMOOTH IS USED.
- ALL TUBES ARE AS PER APL APOLLO STANDARD. CHANGES MAY EFFECT THE LOAD CAPACITY.
- DUAL DIMENSIONS USED WITH BOTH METRIC AND INCH SYSTEM.
- ALL HORIZONTAL AND VERTICAL TUBES ARE PERPENDICULAR TO EACH OTHER WITH ±1 DEG.
- FINE WELDING IS REQUIRED AS PER MENTIONED DETAILS AND FINISHING.
- HIGHER CURRENT WELDING MAY AFFECT THE BRITTLNESS OF MATERIAL WHICH LATER MAY RAISE TO WEAKENING OF STRUCTURE.

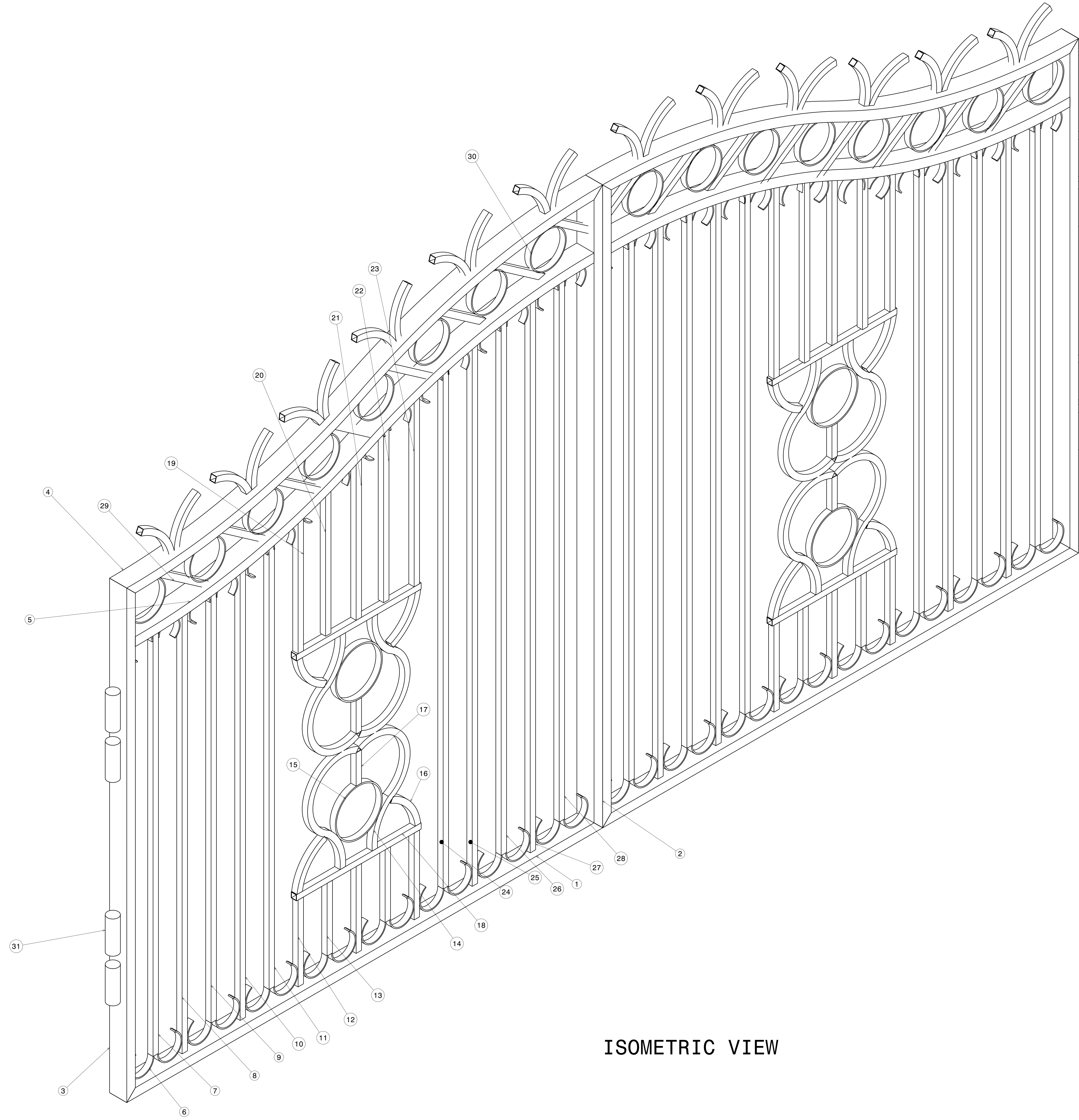

ISOMETRIC VIEW

31	HINGE	SEE DETAILS	8
30	Circular tube 2	SEE DETAILS	16
29	Square tube 34 Frame 24	25 X 25 X 1.6 X 300	16
28	Square tube 34 Frame 23	25 X 25 X 1.6 X 2198.5	2
27	Square tube 34 Frame 22	25 X 25 X 1.6 X 2245.5	2
26	Square tube 34 Frame 21	25 X 25 X 1.6 X 2171.5	2
25	Square tube 34 Frame 20	25 X 25 X 1.6 X 2203.5	2
24	Square tube 34 Frame 19	25 X 25 X 1.6 X 2114	2
23	Square tube 34 Frame 18	25 X 25 X 1.6 X 788.5	2
22	Square tube 34 Frame 17	25 X 25 X 1.6 X 739	2
21	Square tube 34 Frame 16	25 X 25 X 1.6 X 680	2
20	Square tube 34 Frame 15	25 X 25 X 1.6 X 621	2
19	Square tube 34 Frame 14	25 X 25 X 1.6 X 571	2
18	Square tube 34 Frame 13	25 X 25 X 1.6 X 580	4
17	Square tube 34 Frame 12	25 X 25 X 1.6 X 134	4
16	Square tube 34 Curved 2	25 X 25 X 1.6 X SEE DETAILS	56
15	Circular Tube 2	25 X 25 X 1.6 X SEE DETAILS	4
14	Square tube 34 Curved 1	25 X 25 X 1.6 X SEE DETAILS	8
13	Square tube 34 Frame 8	25 X 25 X 1.6 X 293	4
12	Square tube 34 Frame 7	25 X 25 X 1.6 X 350	6
11	Square tube 34 Frame 6	25 X 25 X 1.6 X 1813.5	2
10	Square tube 34 Frame 5	25 X 25 X 1.6 X 1837.5	2
9	Square tube 34 Frame 4	25 X 25 X 1.6 X 1754.5	2
8	Square tube 34 Frame 3	25 X 25 X 1.6 X 1793.5	2
7	Square tube 34 Frame 2	25 X 25 X 1.6 X 1725.5	2
6	Circular Tube 1	SEE DETAILS	32
5	Rectangle tube 34 Frame 2 Curved	SEE DETAILS	2
4	Rectangle tube 34 Frame 1 Curved	SEE DETAILS	2
3	Rectangle Tube 34.1 Frame 3	80 X 40 X 2.9 X 2073.4	2
2	Rectangle Tube 34.1 Frame 2	80 X 40 X 2.9 X 2591	2
1	Rectangle Tube 34.1 Frame 1	80 X 40 X 2.9 X 2115	2

ITEM NO.	PART NUMBER	DESCRIPTION	QTY.
This drawing is our property. It can't be reproduced or communicated without our written agreement.			
DRAWN BY		DATE	
SB		2/28/2020	
CHECKED BY		DATE	
P2P Analysis & Solutions		2/28/2020	
DESIGNED BY		DATE	
P2P Analysis & Solutions		2/28/2020	
DRAWING TITLE		GATE 34	
SIZE	DRAWING NUMBER	REV	
A0	P2P APL 00034	00	
SCALE	NONE	WEIGHT (kg)	240
SHEET		1	

UNLESS OTHERWISE SPECIFIED DIMENSION ARE IN MM VIEWS: THIRD ANGLE PROJECTION



REV	DATE	DESCRIPTION
00	1/28/2020	INITIAL REVISION

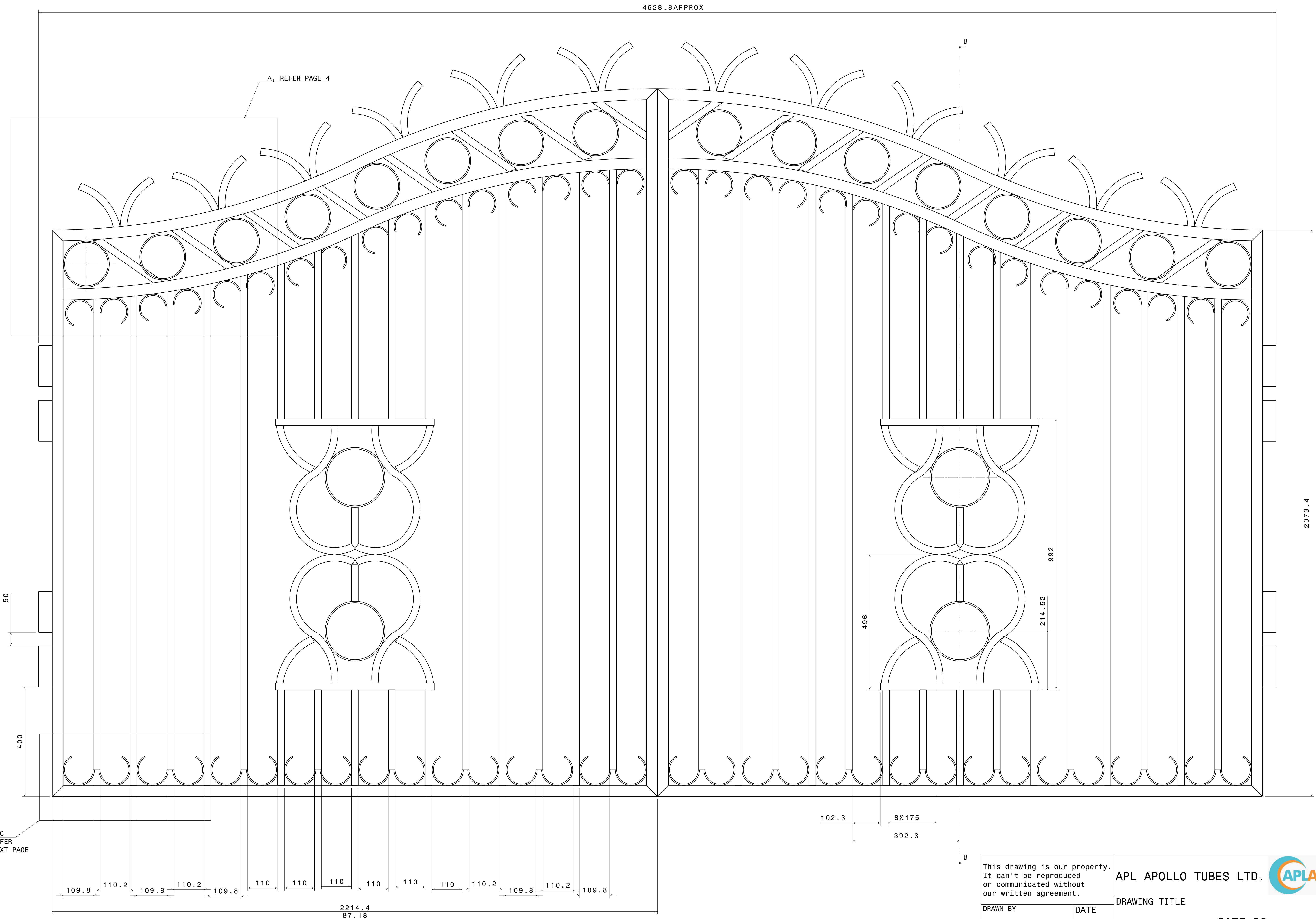

Left view
Scale: 1:5

UNLESS OTHERWISE SPECIFIED DIMENSION ARE IN MM
VIEWS: THIRD ANGLE PROJECTION

DRAWN BY	DATE
SB	1/28/2020
CHECKED BY	DATE
P2P Analysis & Solutions	1/28/2020
DESIGNED BY	DATE
P2P Analysis & Solutions	1/28/2020

This drawing is our property. It can't be reproduced or communicated without our written agreement.

APL APOLLO TUBES LTD.	
DRAWING TITLE	
GATE 30	
SIZE	DRAWING NUMBER
A0	P2P APL_00030
SCALE	WEIGHT (kg)
NONE	XXX
SHEET	2

REV	DATE	DESCRIPTION
00	1/28/2020	INITIAL REVISION

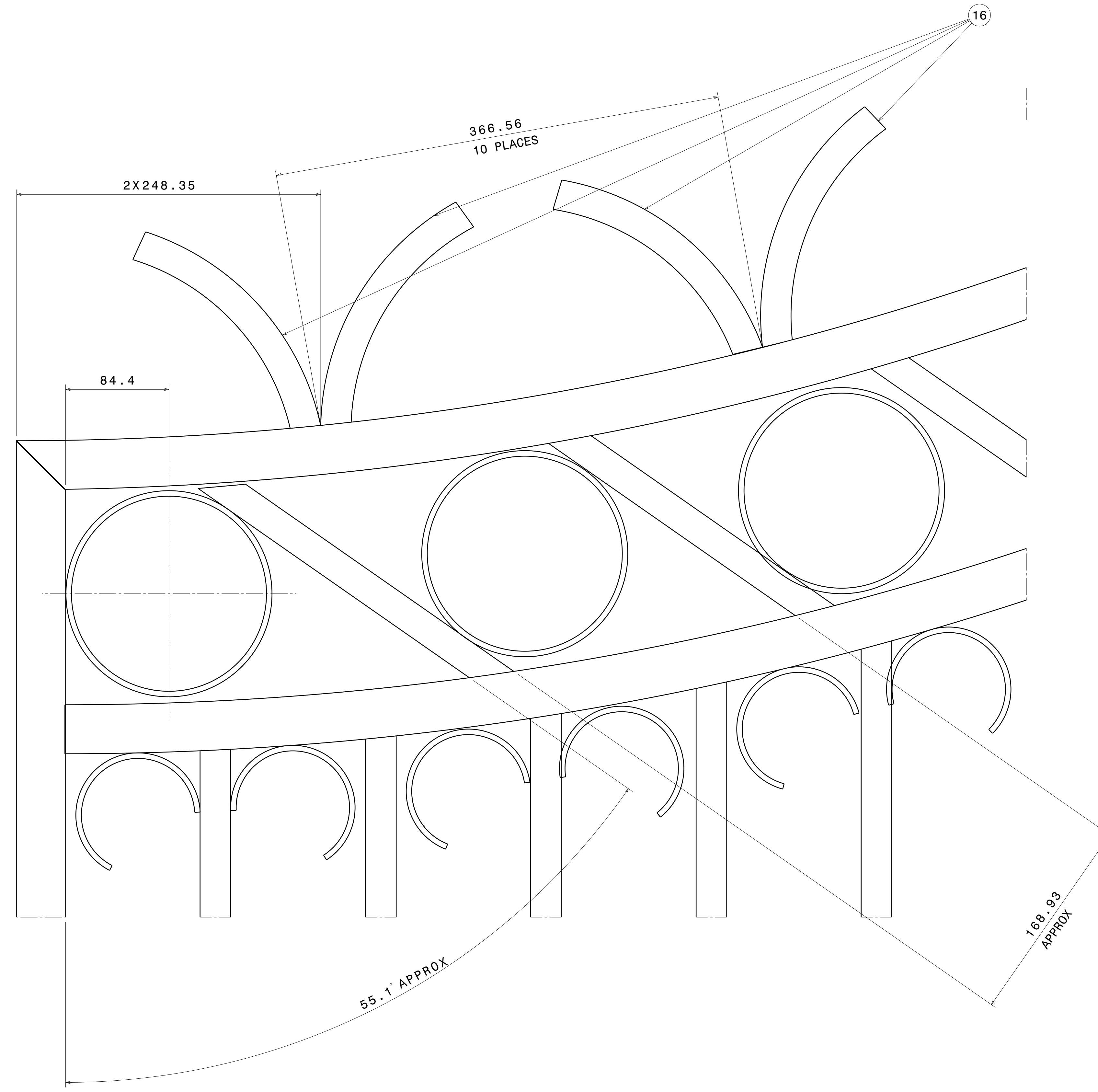

DIMENSIONS ARE APPROXIMATE FABRICATOR IS ALLOWED TO CHANGE DIMENSIONS AND LOCATION OF WELD TO ACHIEVE THE STRUCTURES AS SHOWN. PLEASE NOTE: STRUCTURAL PIECES TO BE WELDED IN SUCH A WAY THAT EVERY PIECE MUST BE WELDED AT MINIMUM TWO PLACES WITH THEIR ADJACENT COMPONENTS.

Detail A
Scale: 1:2

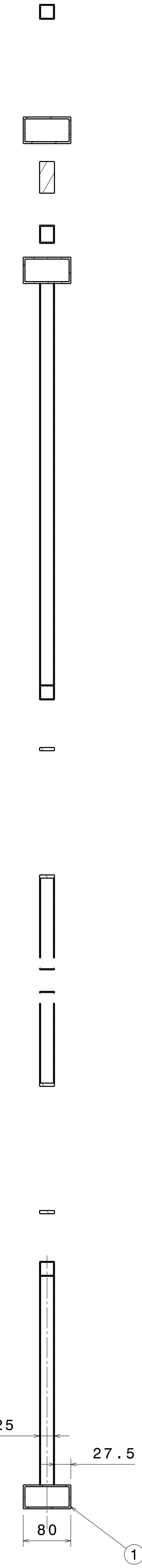

Section cut B-B
Scale: 1:5

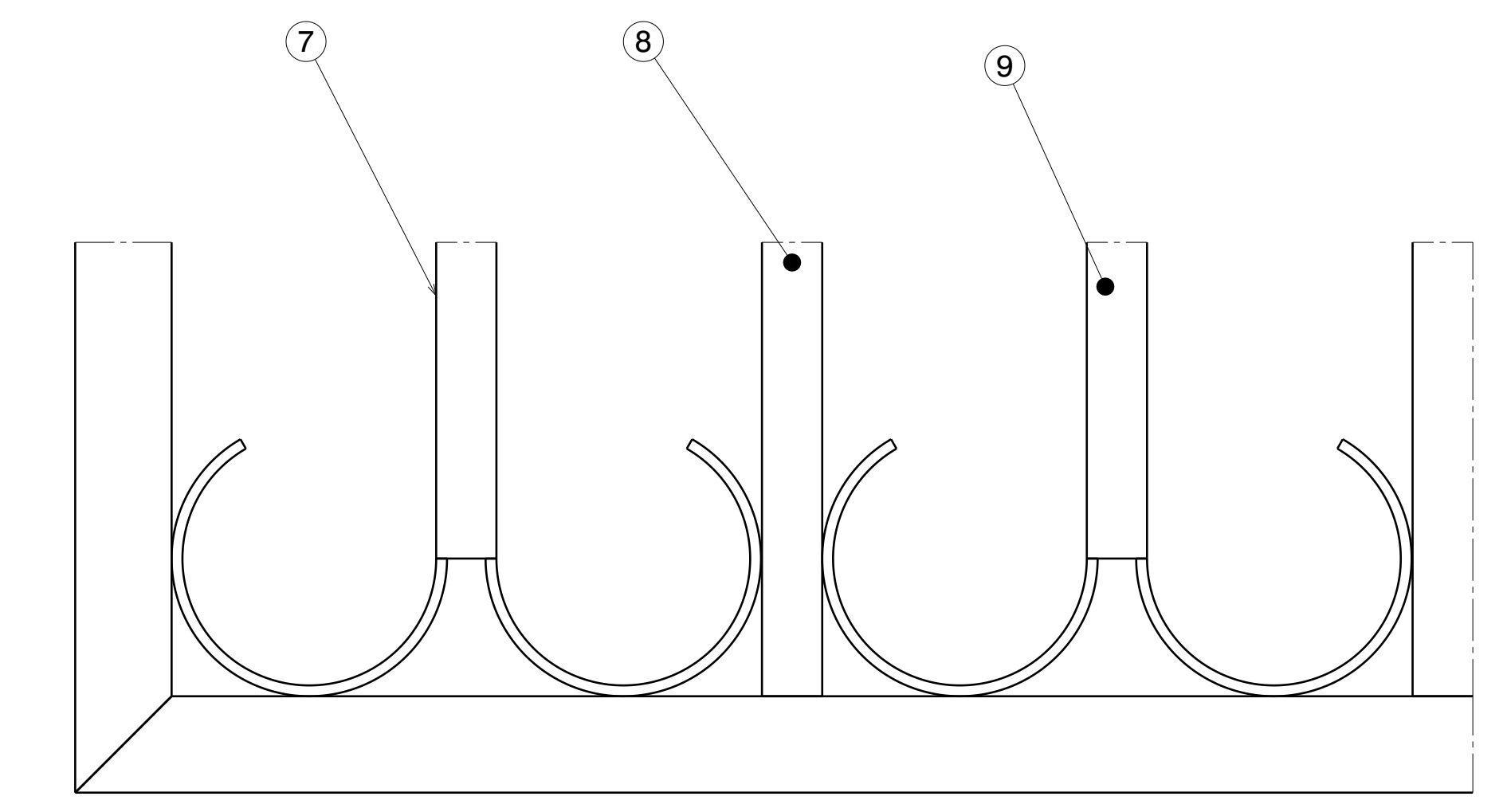

Detail C
Scale: 2:5

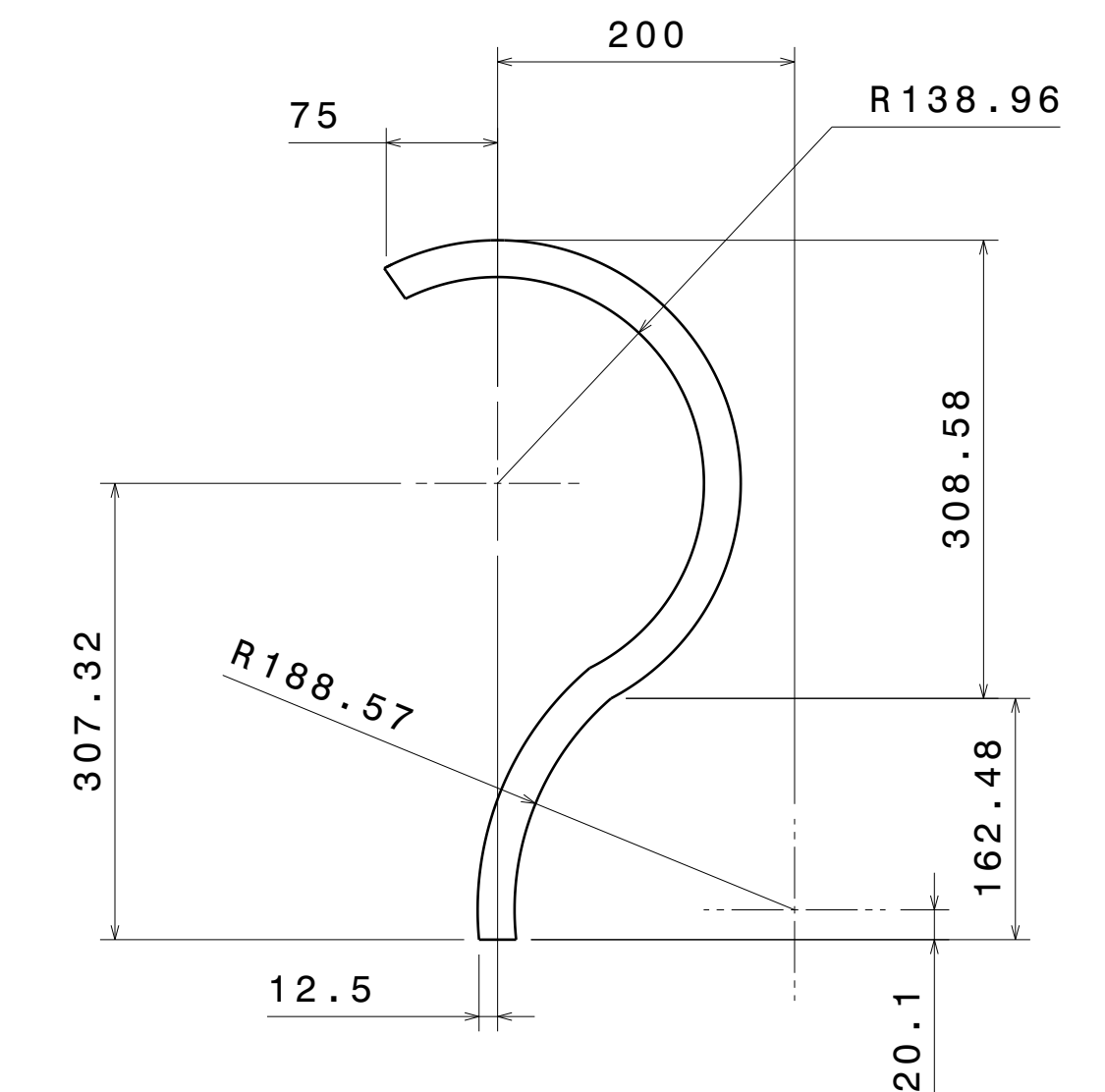

ITEM 14
SECTION: 25X25X1.6

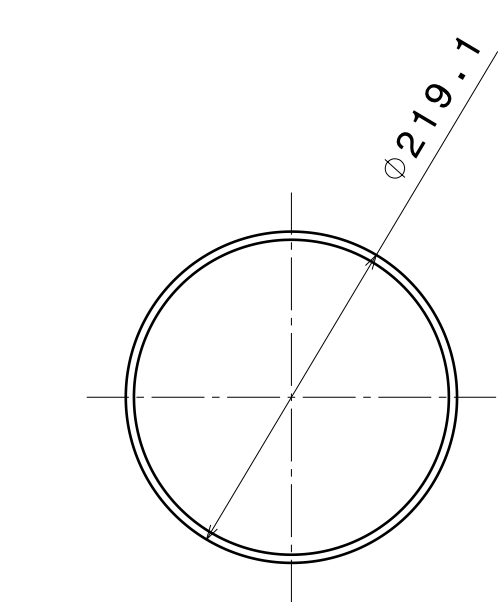

ITEM 15
5.4 THK X 25MM WIDE

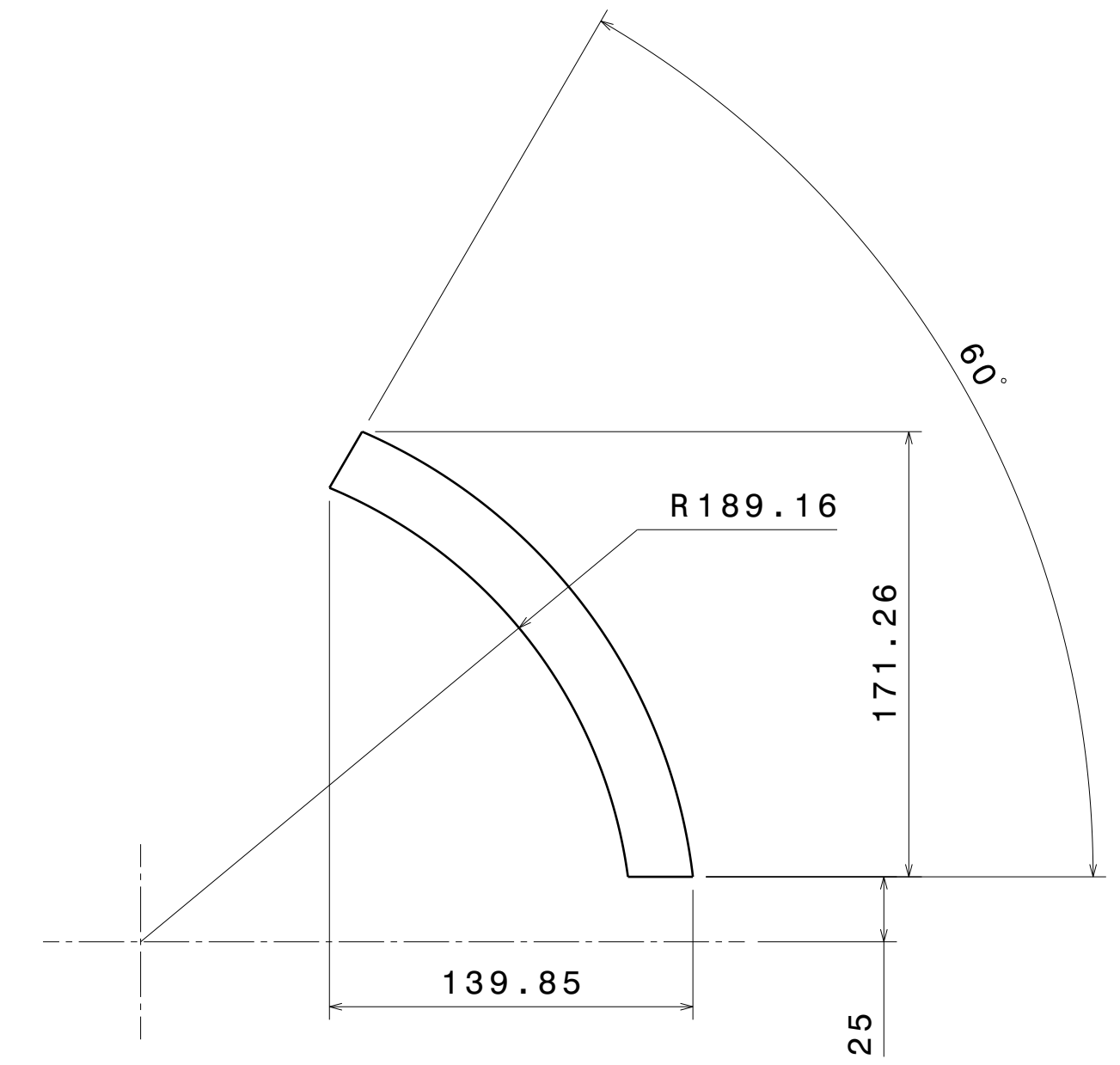

ITEM 16
25X25X1.6

UNLESS OTHERWISE STATED, ALL COMPONENTS ARE SYMMETRICALLY PLACED WITH EACH OTHER

This drawing is our property. It can't be reproduced or communicated without our written agreement.		APL APOLLO TUBES LTD.	
DRAWN BY SB		DATE 2/28/2020	
CHECKED BY P2P Analysis & Solutions		DATE 2/28/2020	
DESIGNED BY P2P Analysis & Solutions		DATE 2/28/2020	
SIZE A0	DRAWING NUMBER P2P APL_00034	REV 00	
SCALE NONE	WEIGHT (kg) XXX	SHEET 3	

UNLESS OTHERWISE SPECIFIED DIMENSION ARE IN MM VIEWS: THIRD ANGLE PROJECTION

REV	DATE	DESCRIPTION
00	1/28/2020	INITIAL REVISION

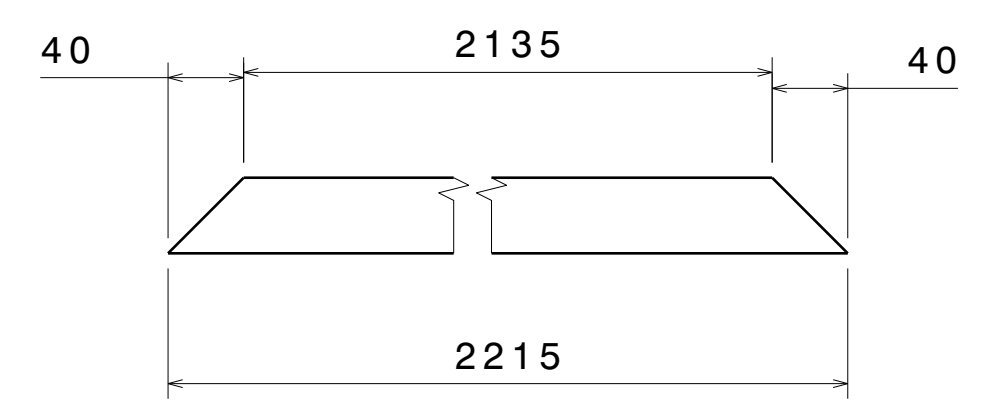

ITEM 1

Right view
Scale: 1:4

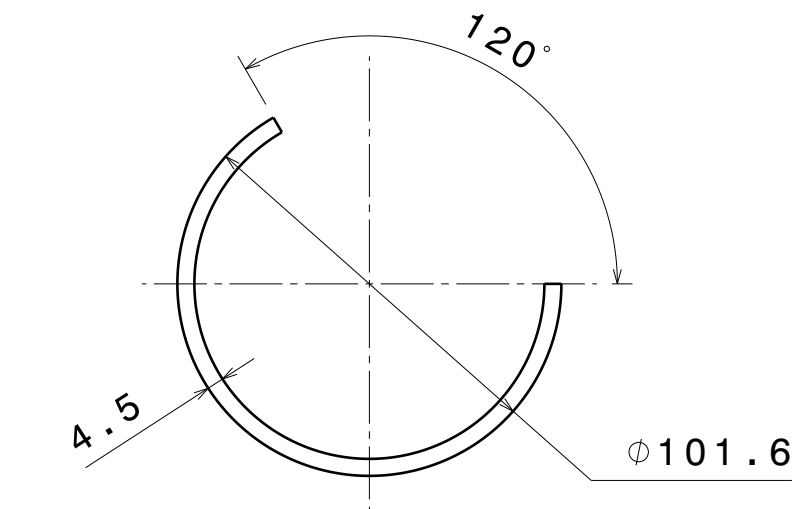

ITEM 6

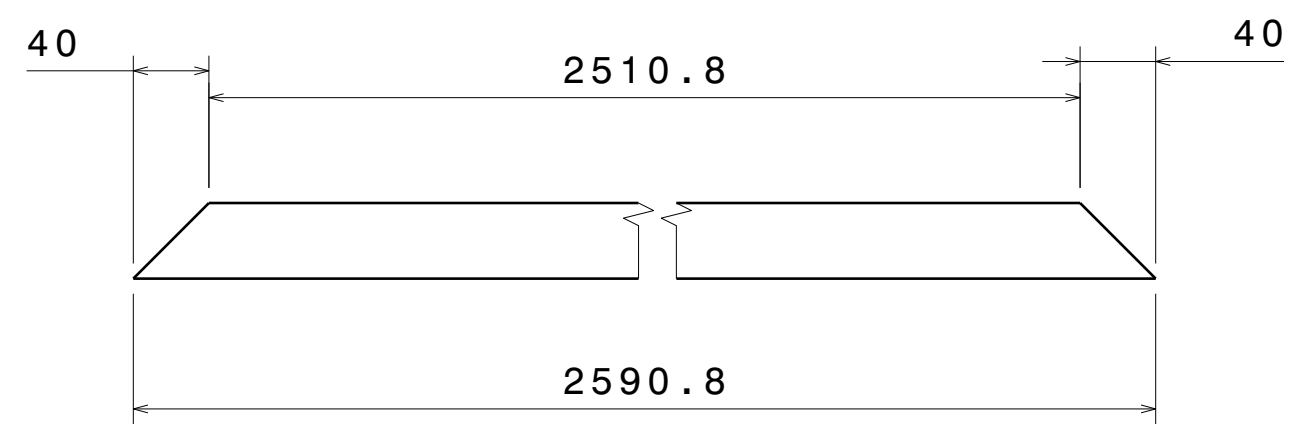

ITEM 2

Right view
Scale: 1:4

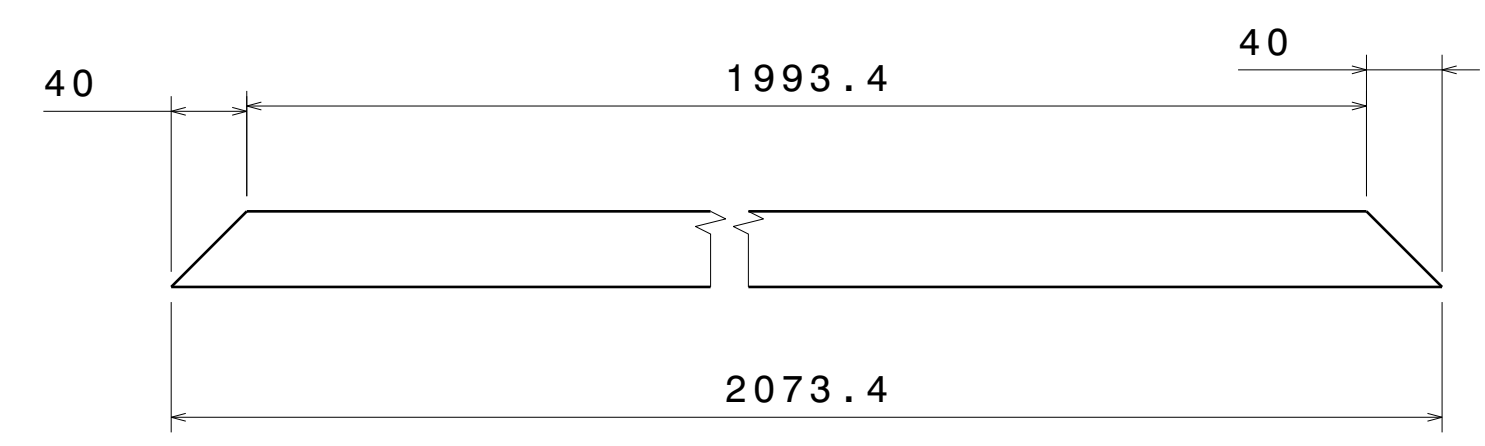

ITEM 3

Right view
Scale: 1:4

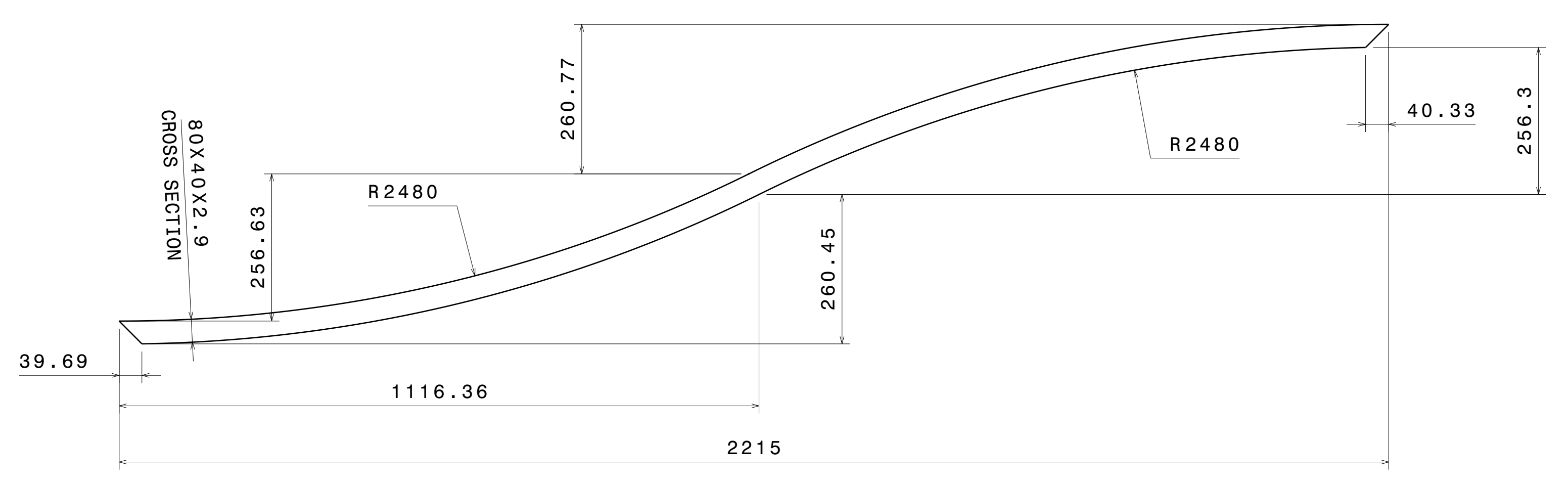

ITEM 4

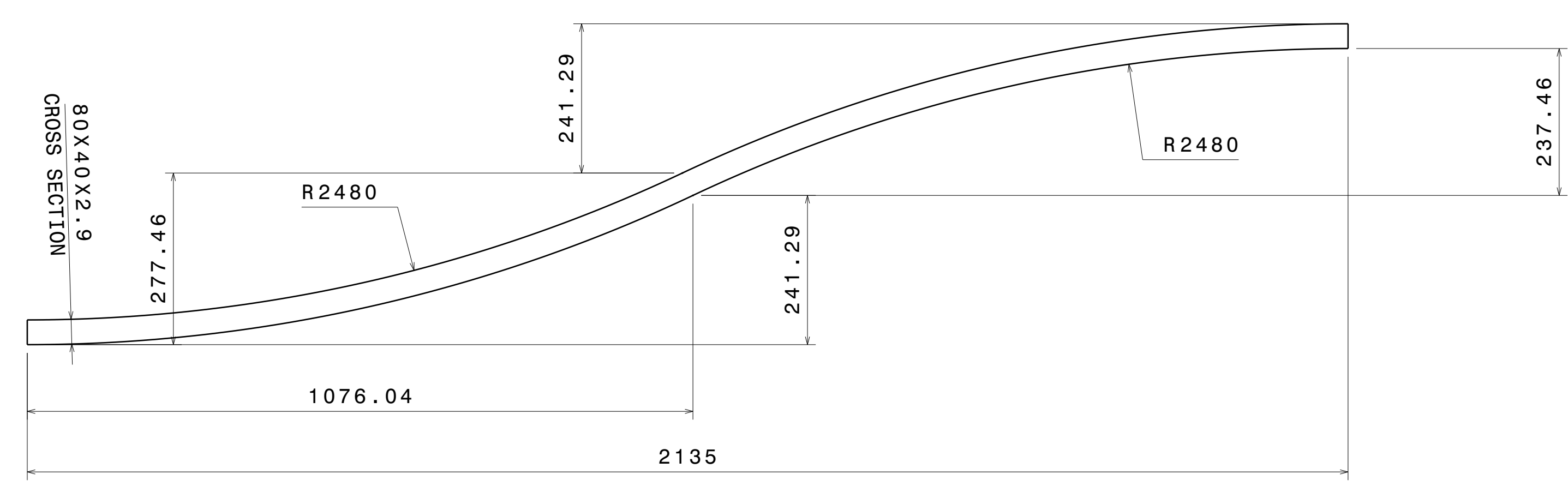

ITEM 5

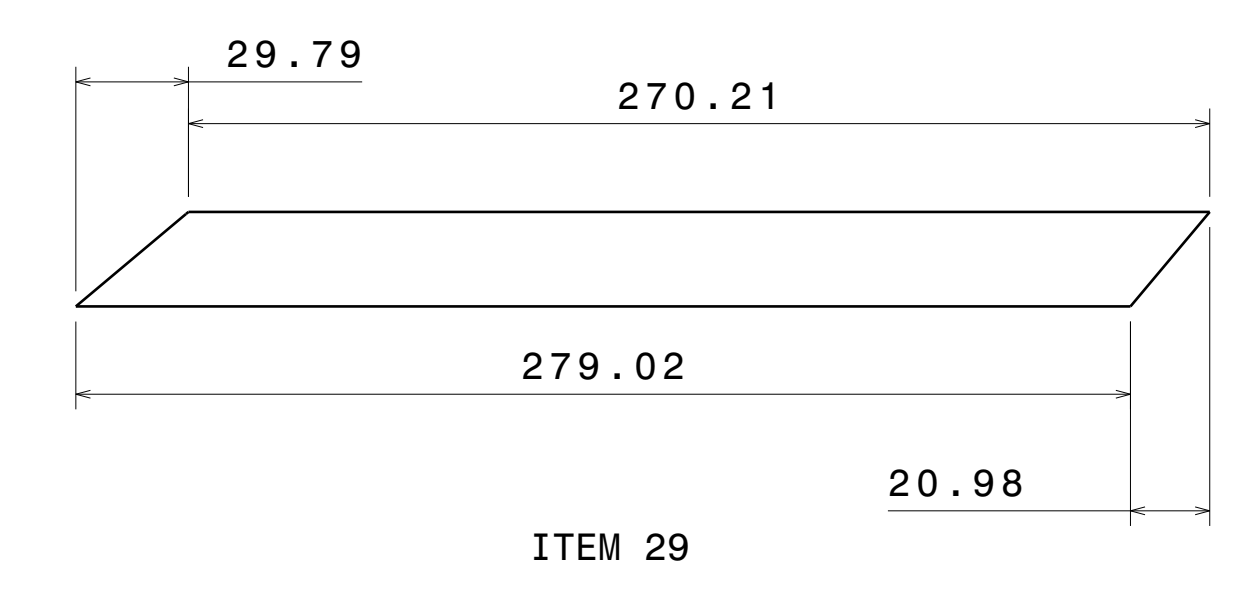
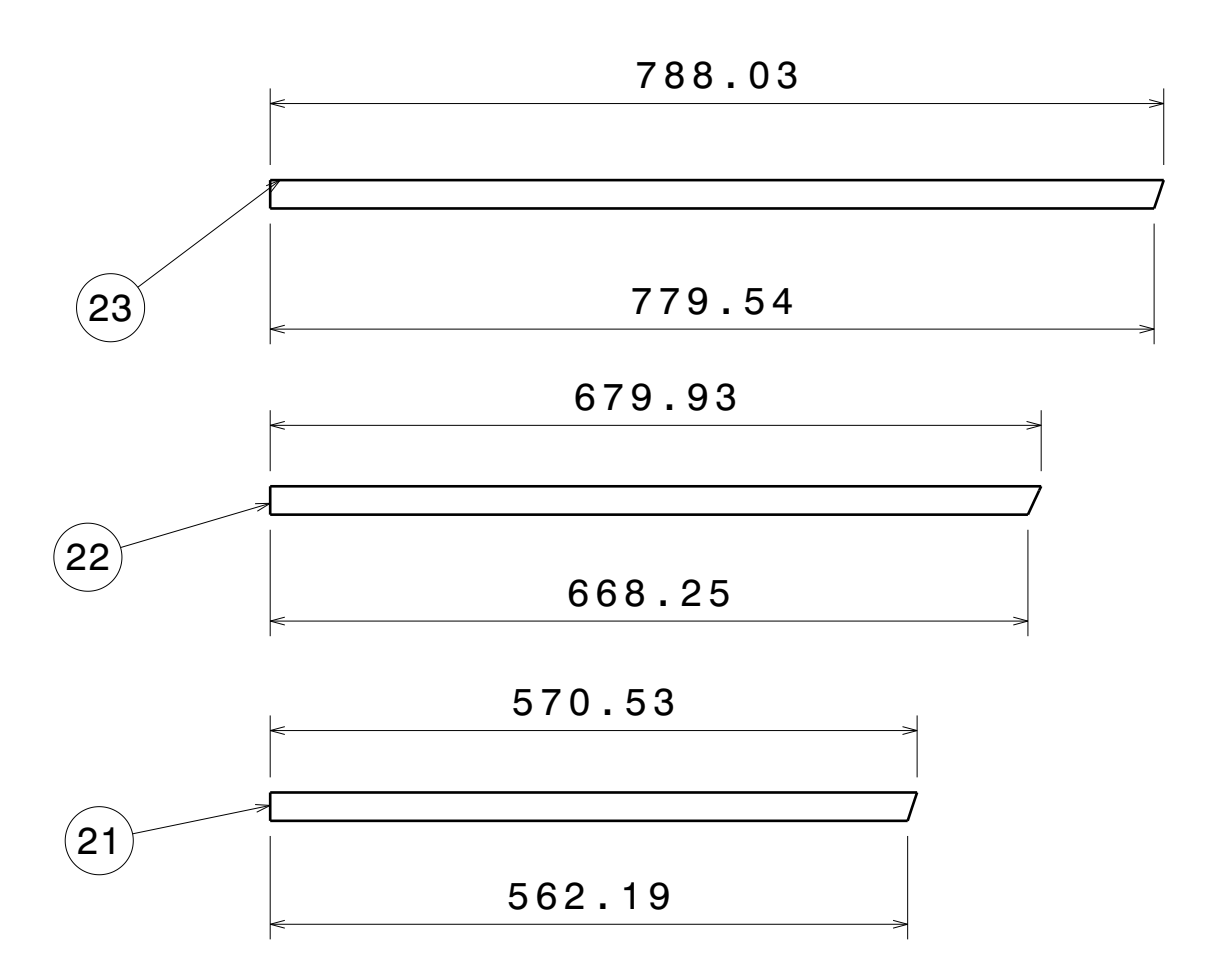
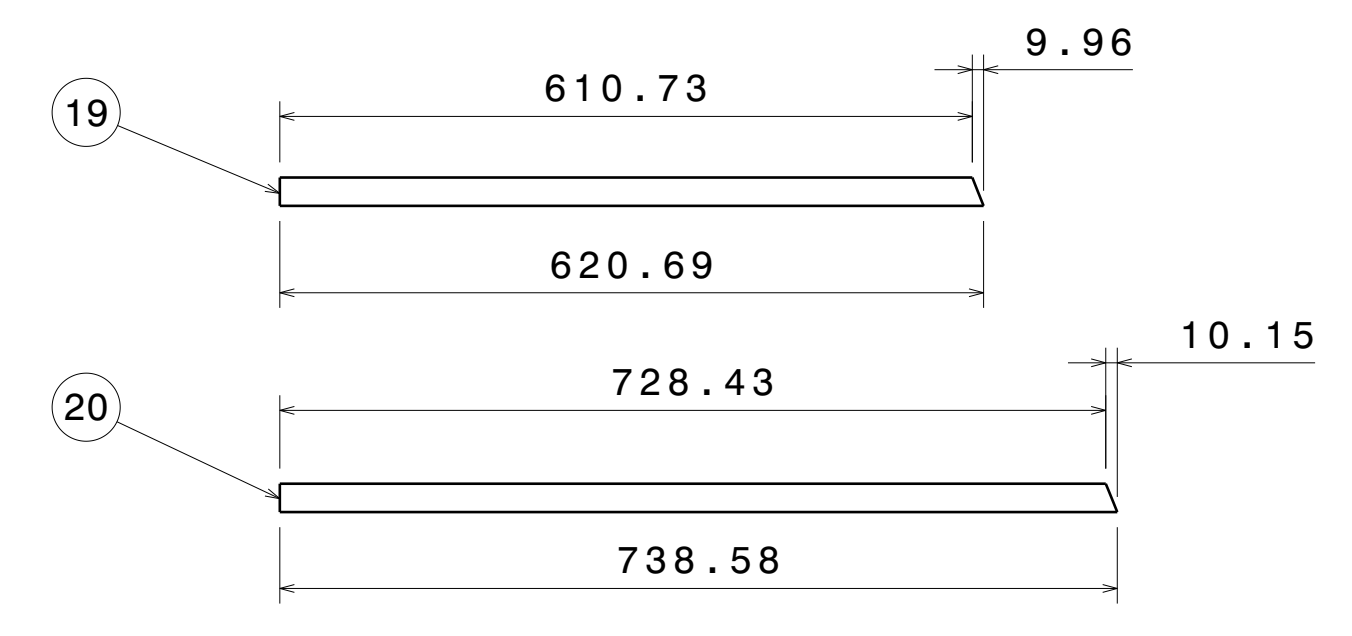

ITEM 29

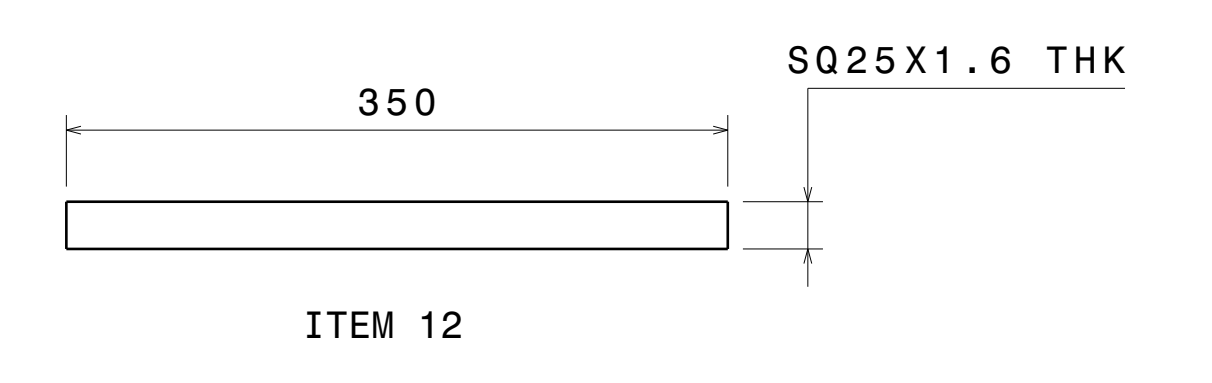
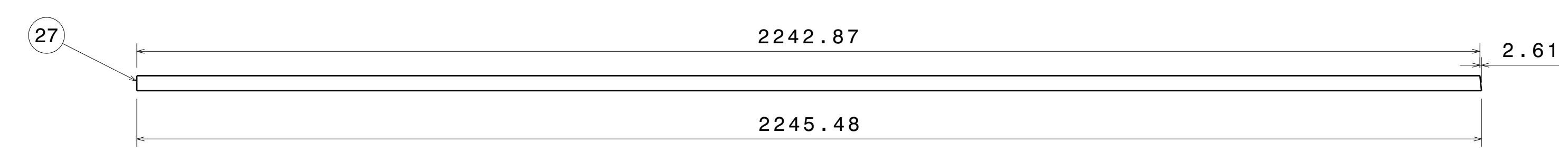
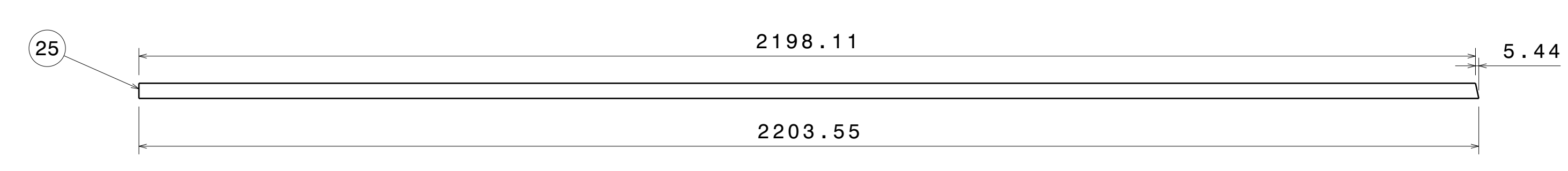
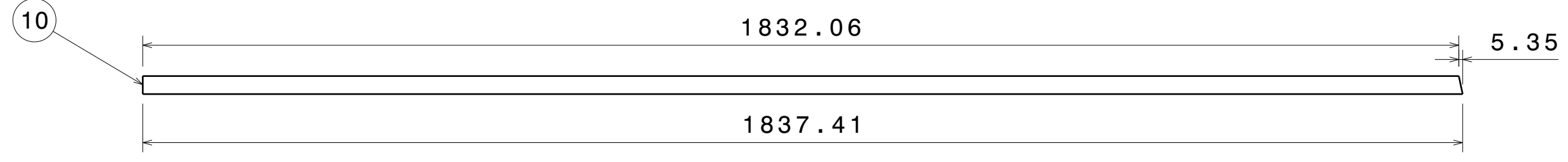
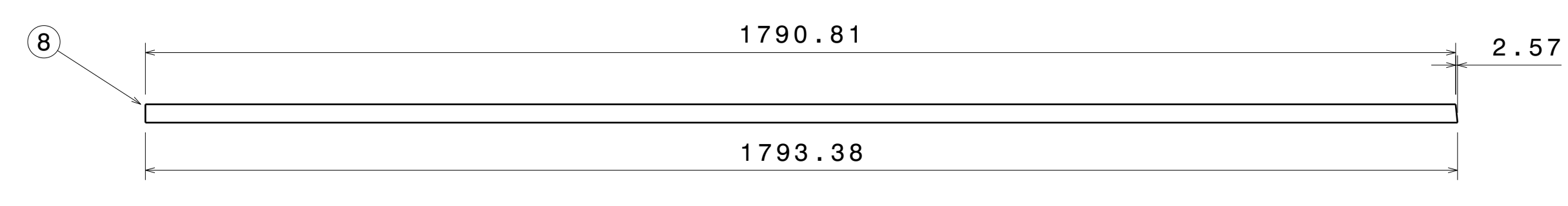
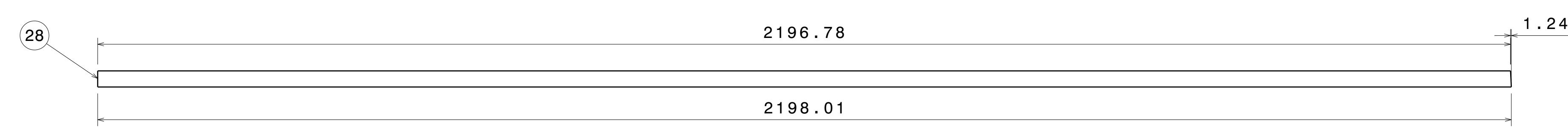
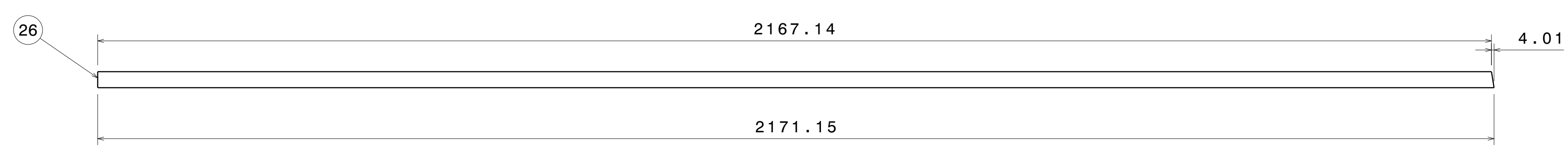
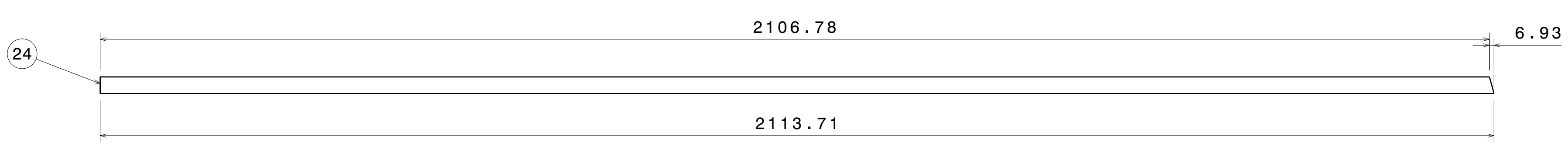
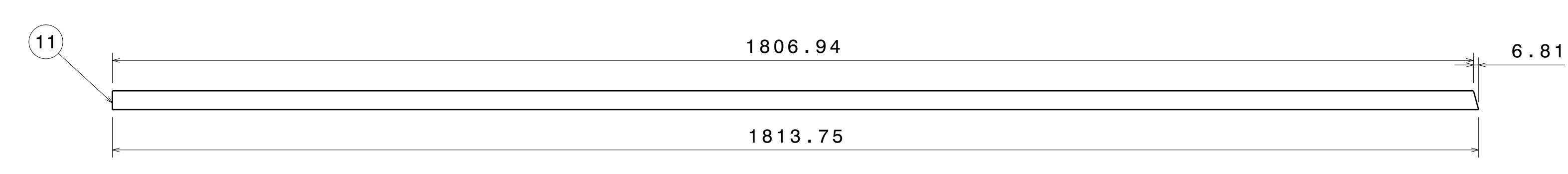
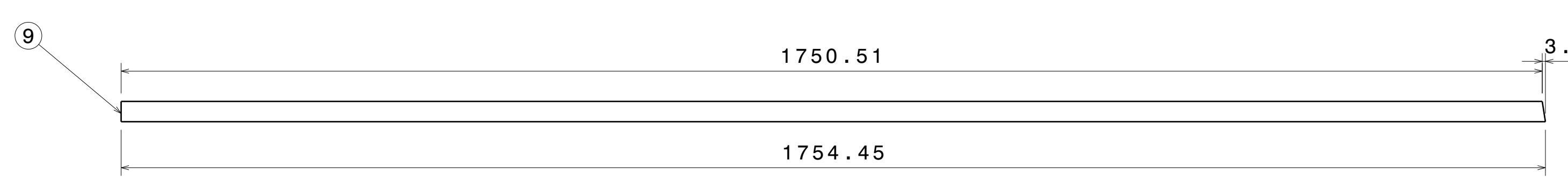
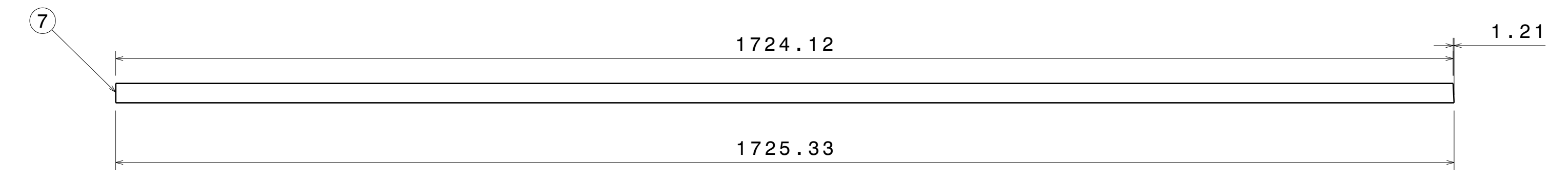

ITEM 12

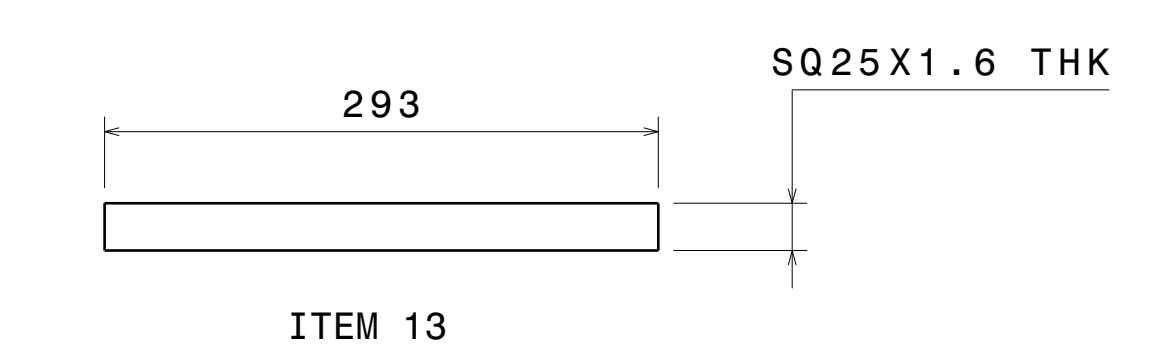

ITEM 13

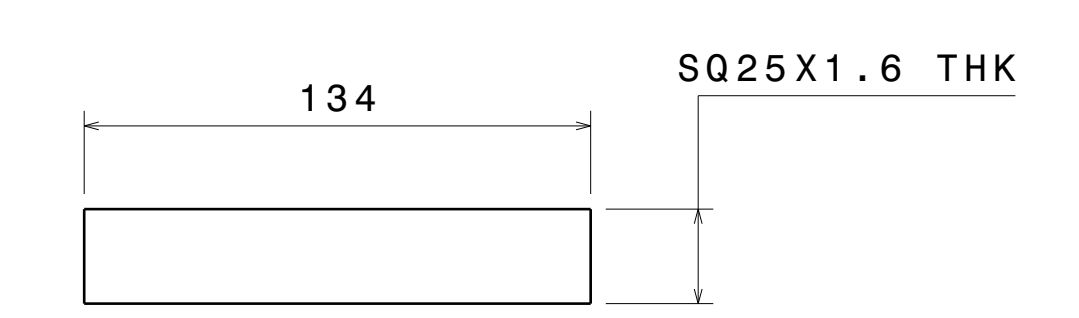

ITEM 18

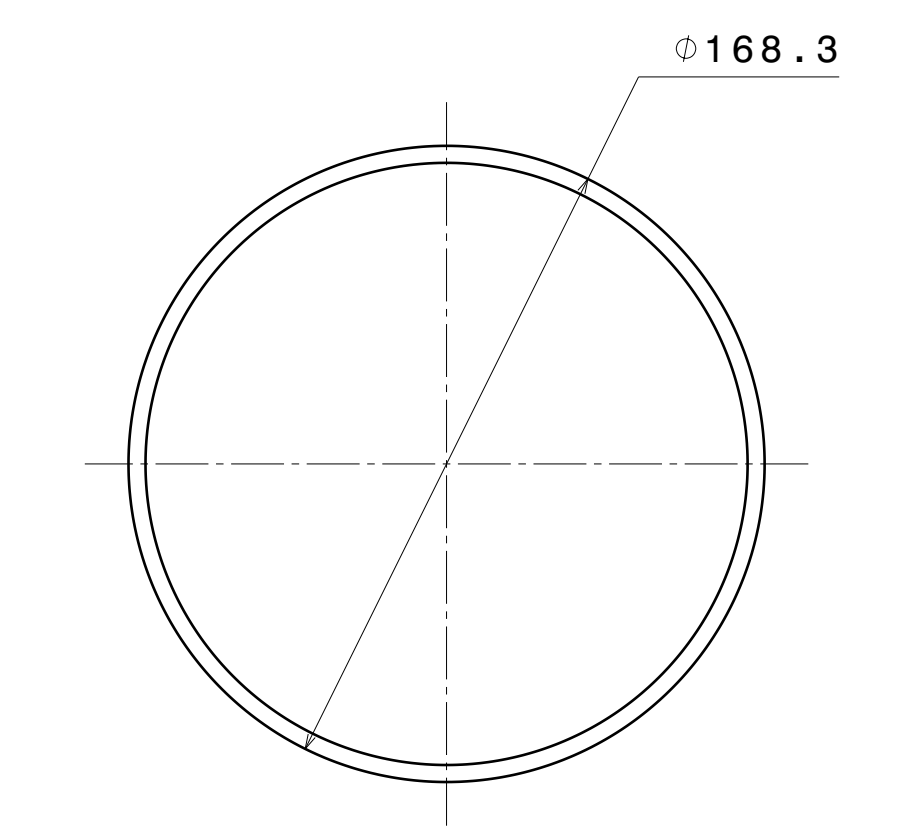

ITEM 30
4.5 THK X 25MM WIDE

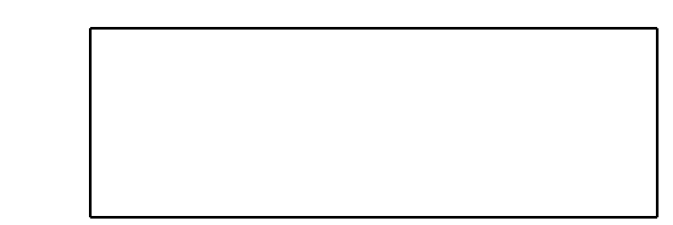

ITEM 31
FOR ILLUSTRATION ONLY
STANDARD COMPONENTS
CAN BE PURCHASED FROM MARKET

UNLESS OTHERWISE SPECIFIED DIMENSION ARE IN MM VIEWS: THIRD ANGLE PROJECTION

This drawing is our property. It can't be reproduced or communicated without our written agreement.

DRAWN BY	DATE
SB	2/28/2020
CHECKED BY	DATE
P2P Analysis & Solutions	2/28/2020
DESIGNED BY	DATE
P2P Analysis & Solutions	2/28/2020

APL APOLLO TUBES LTD.	
DRAWING TITLE	
GATE 34	
SIZE	DRAWING NUMBER
A0	P2P APL 00034
SCALE	WEIGHT (kg)
NONE	XXX
SHEET	4