

REV/DATE	DESCRIPTION
A / 2/26/2020	INITIAL REVISION

- NOTES:
- (⊥) ALL VERTICAL SUPPORTS ARE PERPENDICULAR.
 - FLATNESS OF .5MM IS APPLIED BY DEFAULT.
 - ⊥ WELD BEAD OF 2MM RADIUS IS FOLLOWED.
 - ▽ SURFACE FINISH MEDIUM TO SMOOTH IS USED.
 - ALL TUBES ARE AS PER APL APOLLO STANDARD. CHANGES MAY EFFECT THE LOAD CAPACITY.
 - DUAL DIMENSIONS USED WITH BOTH METRIC AND INCH SYSTEM.
 - ALL HORIZONTAL AND VERTICAL TUBES ARE PERPENDICULAR TO EACH OTHER WITH ±1 DEG.
 - FINE WELDING IS REQUIRED AS PER MENTIONED DETAILS AND FINISHING.
 - HIGHER CURRENT WELDING MAY AFFECT THE BRITTLENESS OF MATERIAL WHICH LATER MAY RAISE TO WEAKENING OF STRUCTURE.

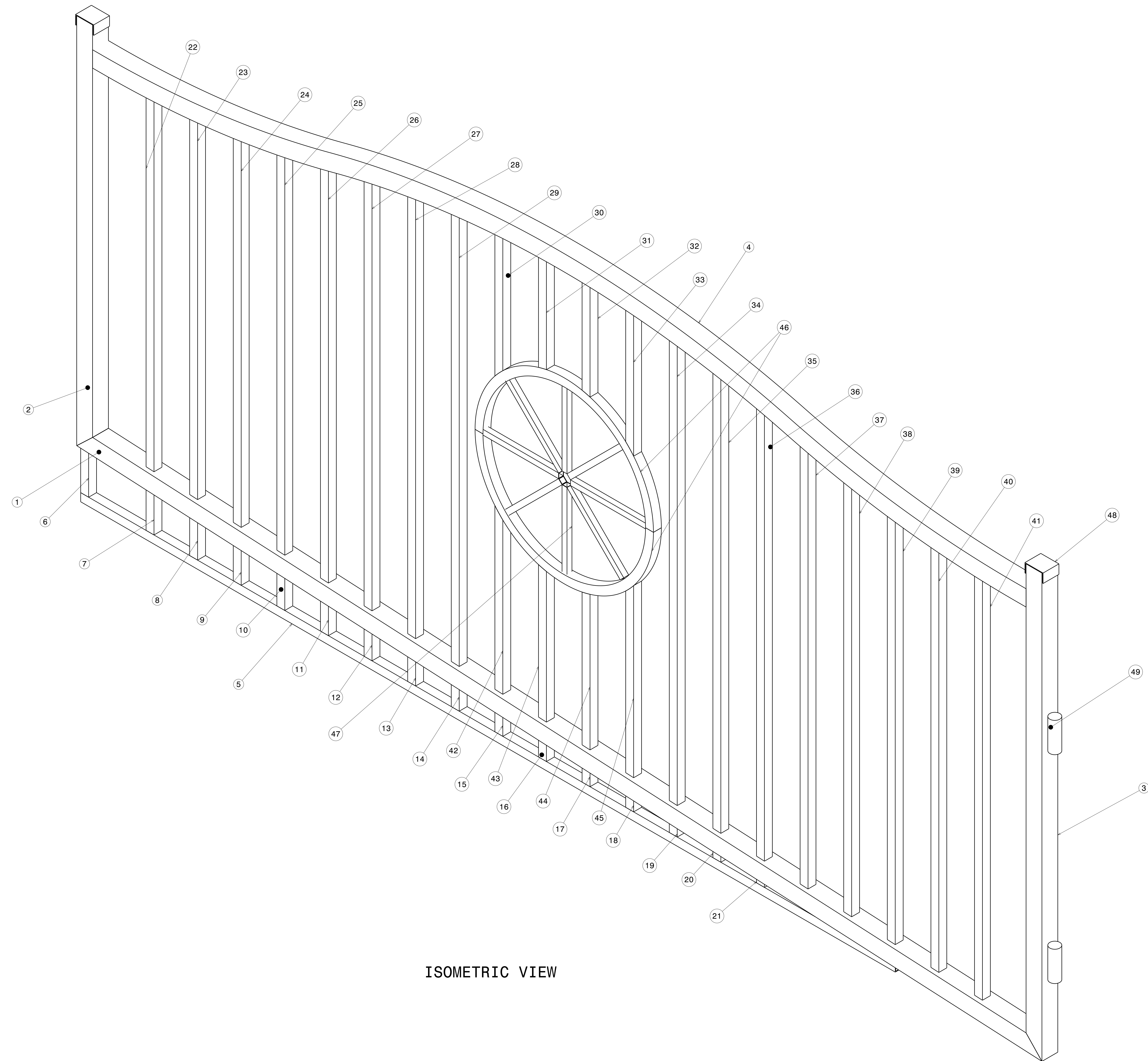

ISOMETRIC VIEW

49	HINGE	SEE DETAILS	2
48	Square Tube 22 Medium 40	SEE DETAILS	1
47	Square Tube 22 Medium 43	SEE DETAILS	8
46	Square Tube 22 Semi Circular	SEE DETAILS	2
45	Square Tube 22 Medium 40	SEE DETAILS	1
44	Square Tube 22 Medium 39	SEE DETAILS	1
43	Square Tube 22 Medium 38	SEE DETAILS	1
42	Square Tube 22 Medium 37	SEE DETAILS	1
41	Square Tube 22 Medium 36	SEE DETAILS	1
40	Square Tube 22 Medium 35	SEE DETAILS	1
39	Square Tube 22 Medium 34	SEE DETAILS	1
38	Square Tube 22 Medium 33	SEE DETAILS	1
37	Square Tube 22 Medium 32	SEE DETAILS	1
36	Square Tube 22 Medium 31	SEE DETAILS	1
35	Square Tube 22 Medium 30	SEE DETAILS	1
34	Square Tube 22 Medium 29	SEE DETAILS	1
33	Square Tube 22 Medium 28	SEE DETAILS	1
32	Square Tube 22 Medium 27	SEE DETAILS	1
31	Square Tube 22 Medium 26	SEE DETAILS	1
30	Square Tube 22 Medium 25	SEE DETAILS	1
29	Square Tube 22 Medium 24	SEE DETAILS	1
28	Square Tube 22 Medium 23	SEE DETAILS	1
27	Square Tube 22 Medium 22	SEE DETAILS	1
26	Square Tube 22 Medium 21	SEE DETAILS	1
25	Square Tube 22 Medium 20	SEE DETAILS	1
24	Square Tube 22 Medium 19	SEE DETAILS	1
23	Square Tube 22 Medium 18	SEE DETAILS	1
22	Square Tube 22 Medium 17	SEE DETAILS	1
21	Square Tube 22 Medium 16	SEE DETAILS	1
20	Square Tube 22 Medium 15	SEE DETAILS	1
19	Square Tube 22 Medium 14	SEE DETAILS	1
18	Square Tube 22 Medium 13	SEE DETAILS	1
17	Square Tube 22 Medium 12	SEE DETAILS	1
16	Square Tube 22 Medium 11	SEE DETAILS	1
15	Square Tube 22 Medium 10	SEE DETAILS	1
14	Square Tube 22 Medium 9	SEE DETAILS	1
13	Square Tube 22 Medium 8	SEE DETAILS	1
12	Square Tube 22 Medium 7	SEE DETAILS	1
11	Square Tube 22 Medium 6	SEE DETAILS	1
10	Square Tube 22 Medium 5	SEE DETAILS	1
9	Square Tube 22 Medium 4	SEE DETAILS	1
8	Square Tube 22 Medium 3	SEE DETAILS	1
7	Square Tube 22 Medium 2	SEE DETAILS	1
6	Square Tube 22 Medium 1	SEE DETAILS	1
5	Square Tube 22 Frame 4	40 X 40 X 2.6 X 4110	1
4	Square Tube 22 Frame 1 - Curved	SEE DETAILS	1
3	Square Tube 22 Frame 3	80 X 80 X 4 X 1879	1
2	Square Tube 22 Frame 2	80 X 80 X 4 X 2134	1
1	Square Tube 22 Frame 1	80 X 80 X 4 X 4877	1
ITEM NO.	PART DESCRIPTION	DESCRIPTION	QUANTITY

This drawing is our property. It can't be reproduced or communicated without our written agreement.

APL APOLLO TUBES LTD.

DRAWING TITLE: **GATE 22**

DRAWN BY: SB	DATE: 2/26/2020	CHECKED BY: P2P Analysis & Solutions	DATE: 2/26/2020	DESIGNED BY: P2P Analysis & Solutions	DATE: 2/26/2020
--------------	-----------------	--------------------------------------	-----------------	---------------------------------------	-----------------

SIZE: A0	DRAWING NUMBER: P2P APL 00022	REV: 00
SCALE: NONE	WEIGHT (kg): 265	SHEET: 1

UNLESS OTHERWISE SPECIFIED DIMENSION ARE IN MM VIEWS: THIRD ANGLE PROJECTION

REV	DATE	DESCRIPTION
00	2/26/2020	INITIAL REVISION

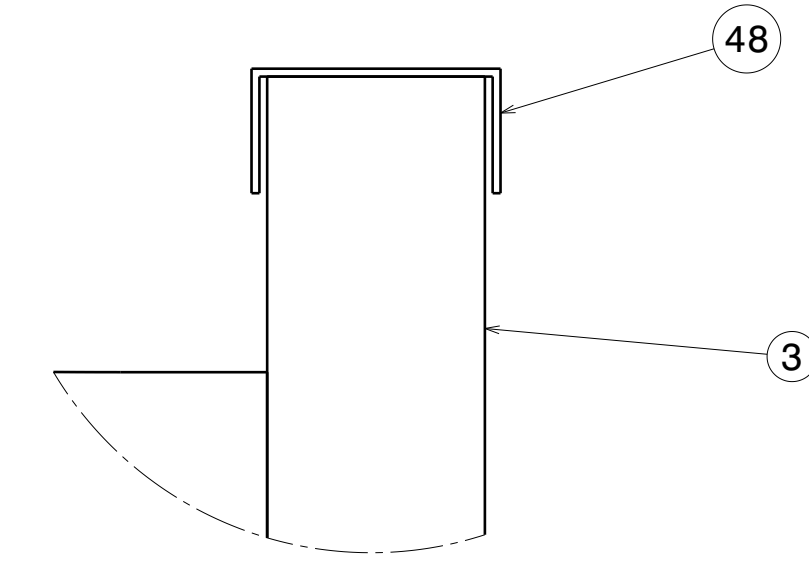

Detail A (2 PLACES)
ITEM 48 TO BE
PLACED ON TOP OF
ITEM AS SHOWN

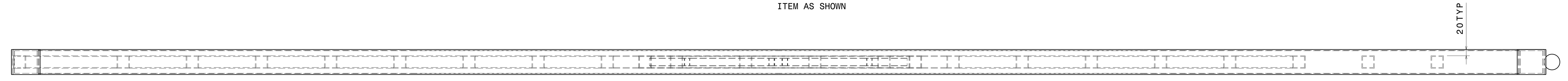

Top view
Scale: 9:50

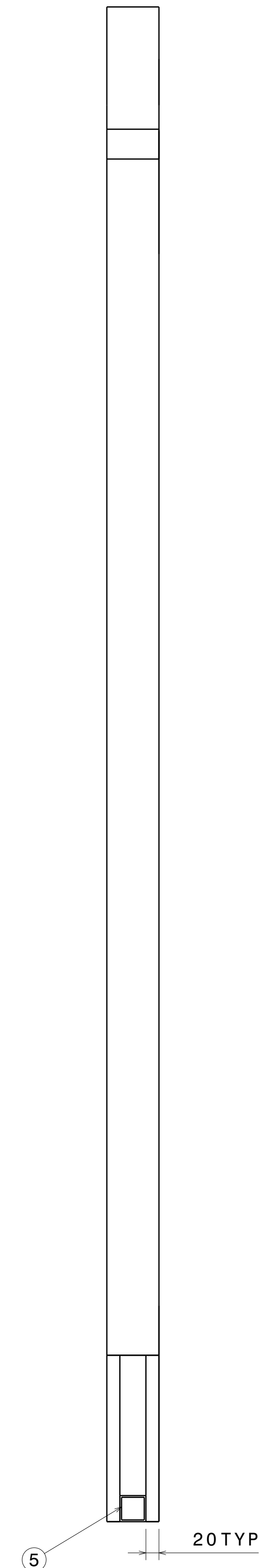

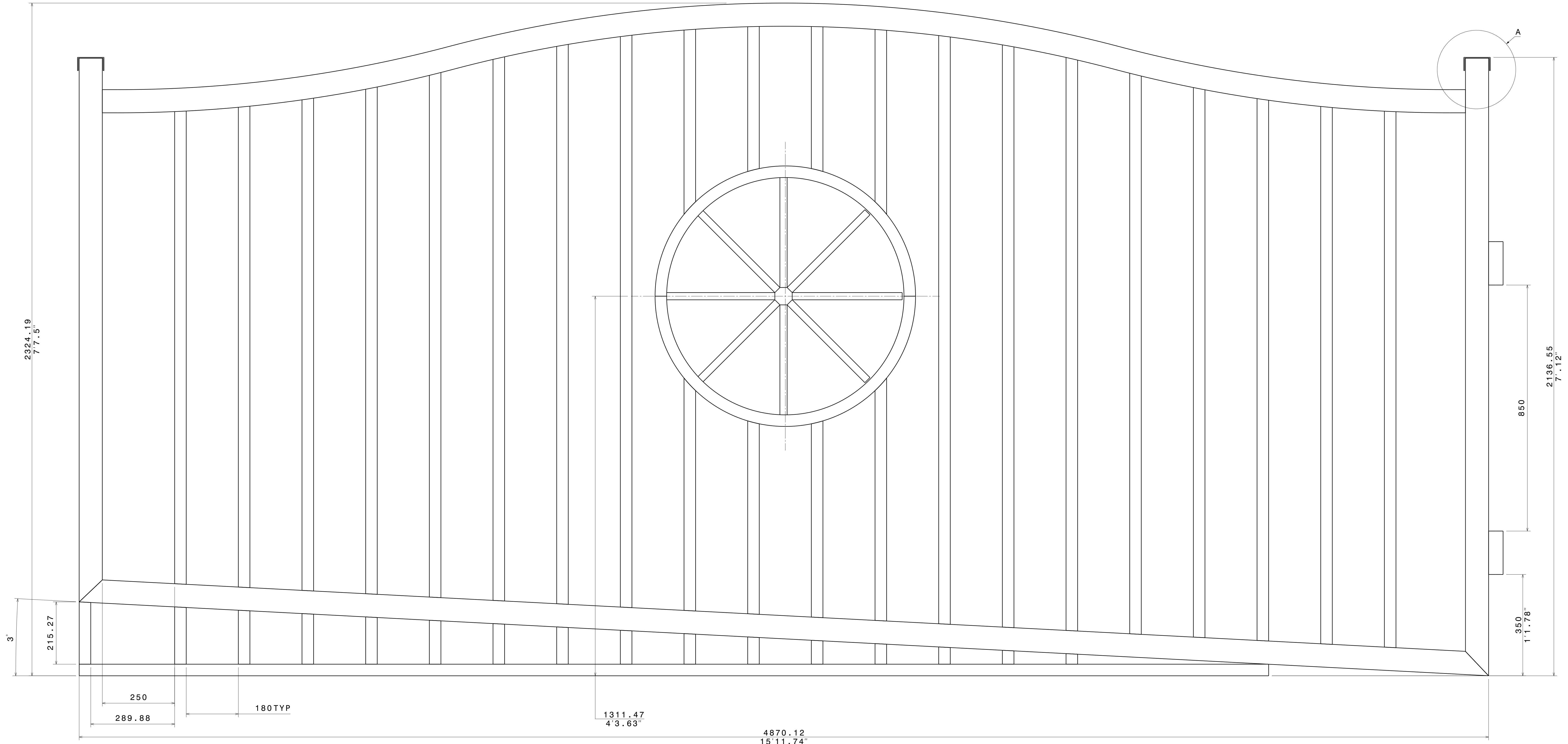

Left view
Scale: 9:50

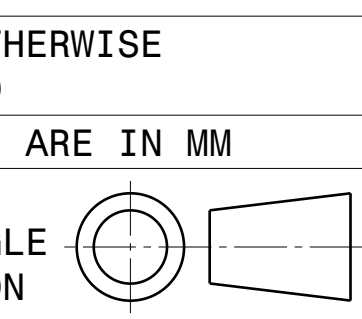

Front view
Scale: 9:50

UNLESS OTHERWISE SPECIFIED DIMENSION ARE IN MM VIEWS: THIRD ANGLE PROJECTION



This drawing is our property. It can't be reproduced or communicated without our written agreement.		APL APOLLO TUBES LTD. 	
DRAWN BY SB		DATE 2/26/2020	
CHECKED BY P2P Analysis & Solutions		DATE 2/26/2020	
DESIGNED BY P2P Analysis & Solutions		DATE 2/26/2020	
SIZE A0	DRAWING NUMBER P2P APL_00022	REV 00	
SCALE NONE	WEIGHT (kg) XXX	SHEET 2	

REV	DATE	DESCRIPTION
00	2/26/2020	INITIAL REVISION

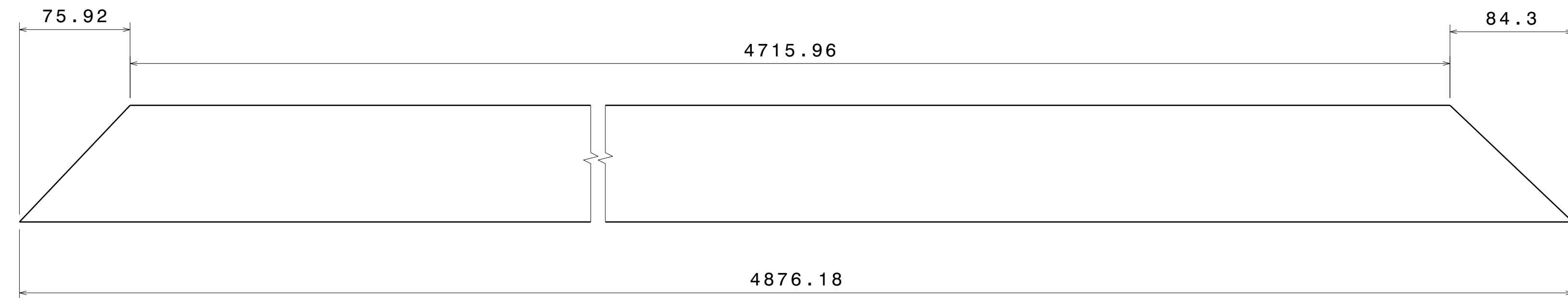

ITEM 1

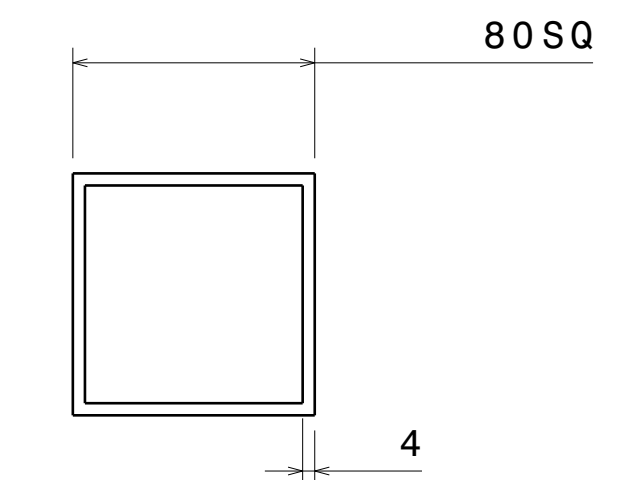

Right view
Scale: 2:5

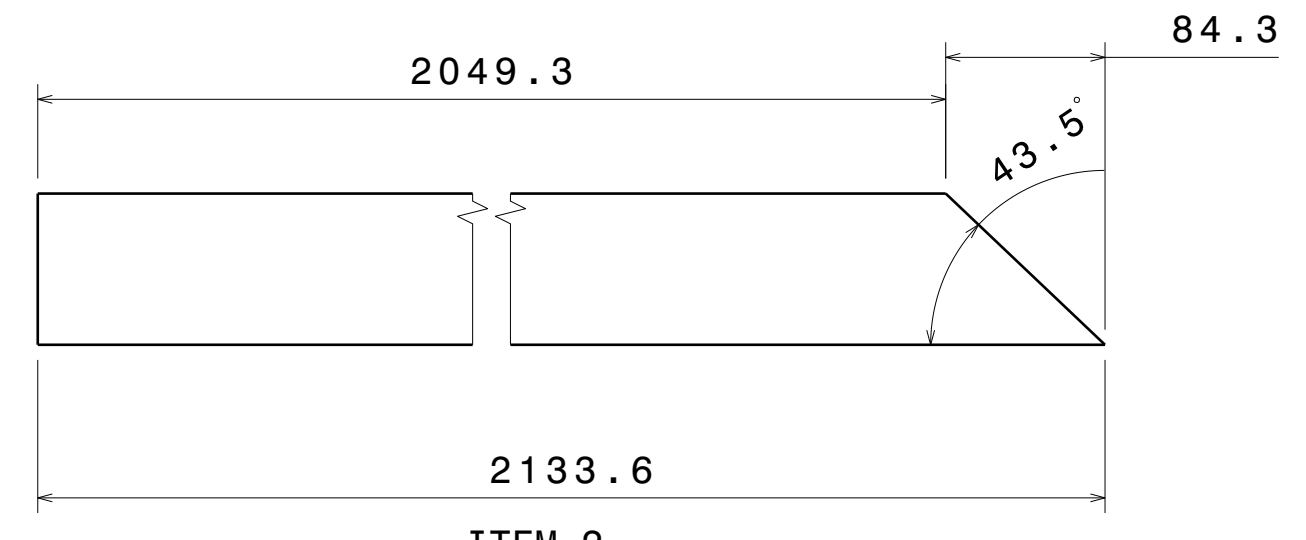

ITEM 2

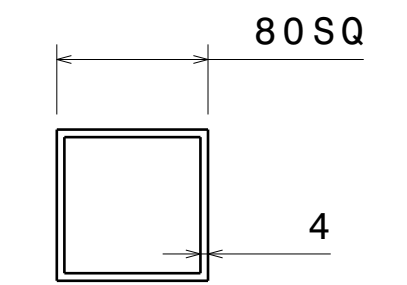

Right view
Scale: 1:4

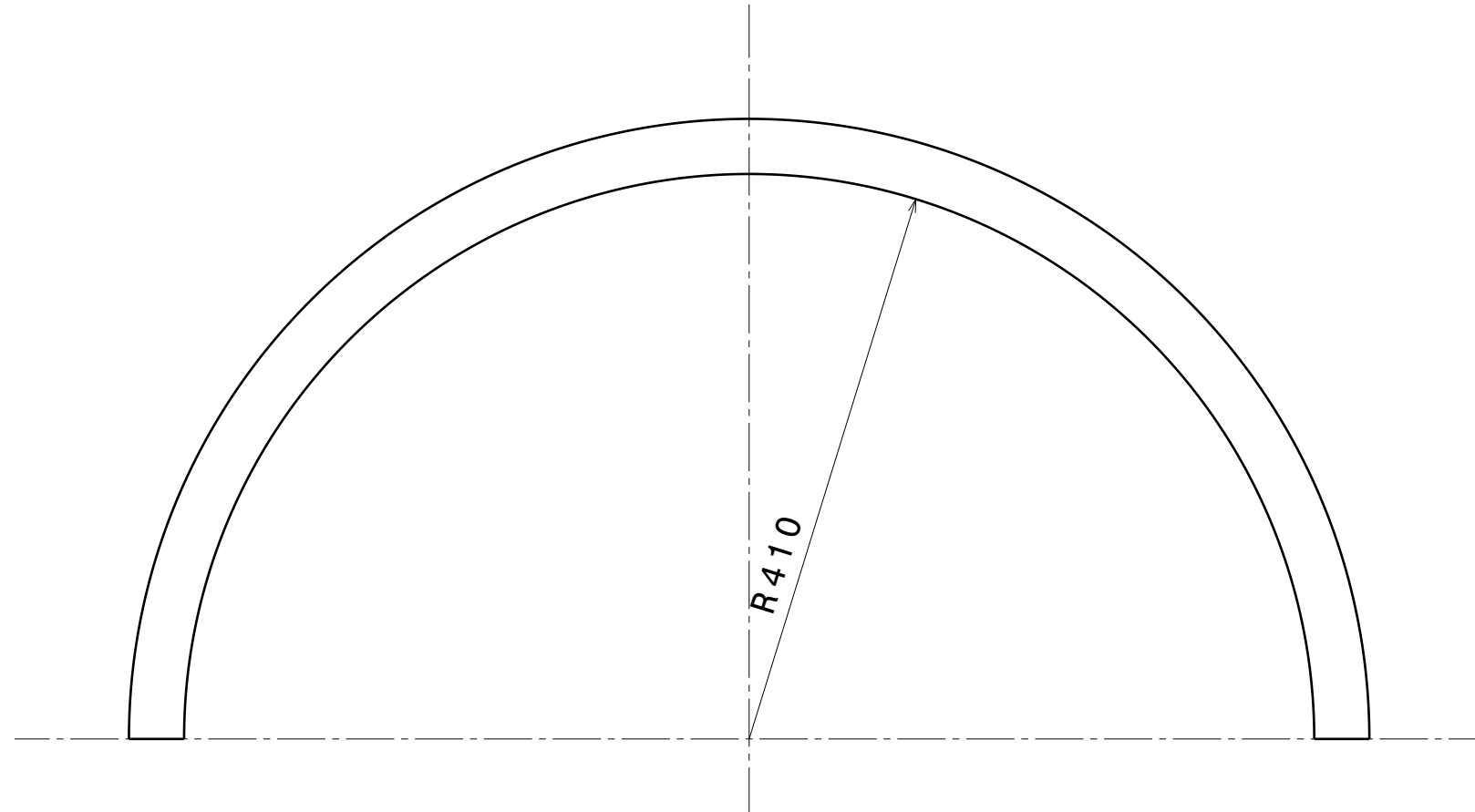

ITEM 46
CROSS SECTION: 25 X 25 X 1.6

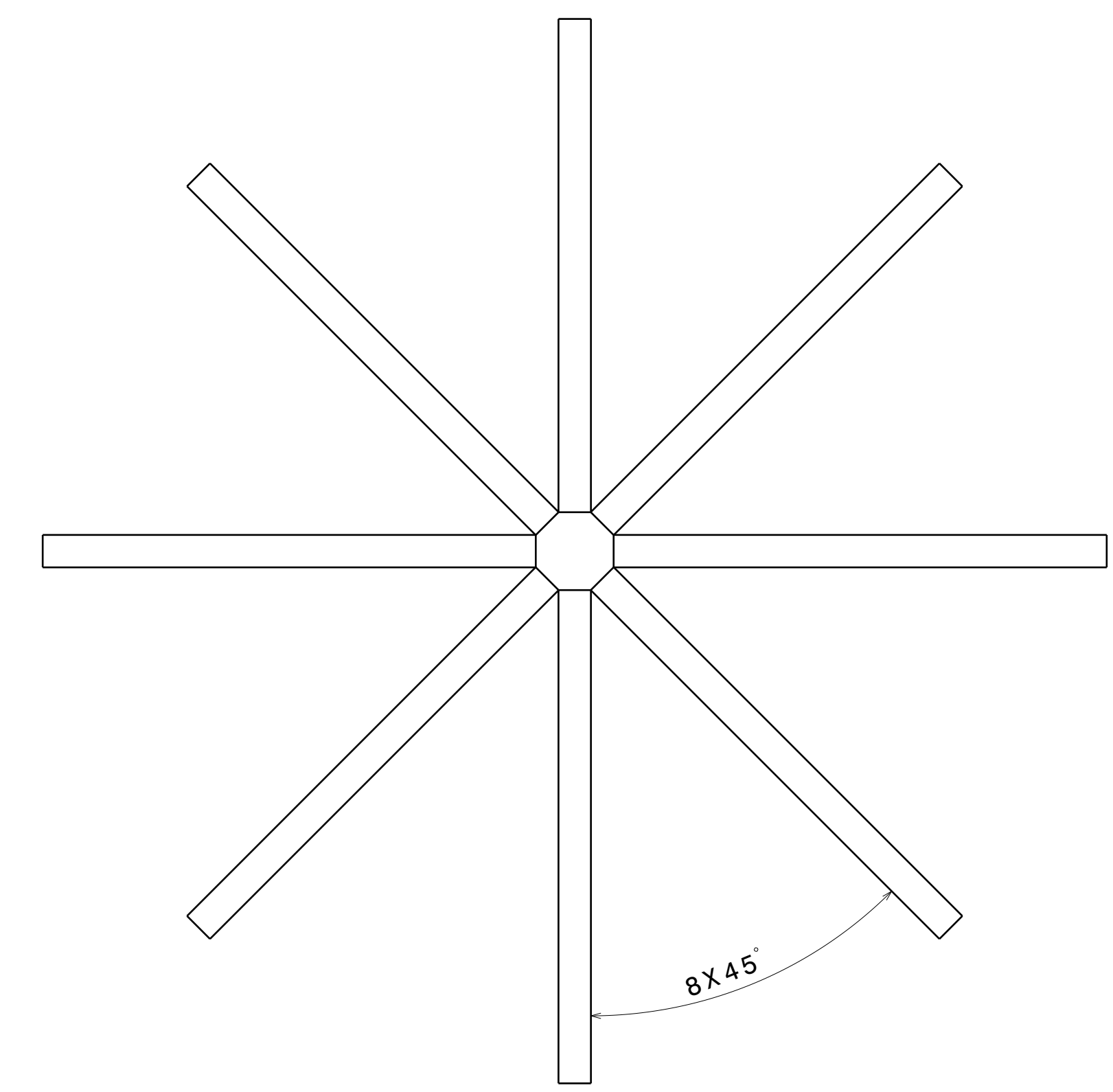

ITEM 47, QTY 8, WELDED TOGETHER AS SHOWN
SIZE: 25 X 25 X 1.6 X 380

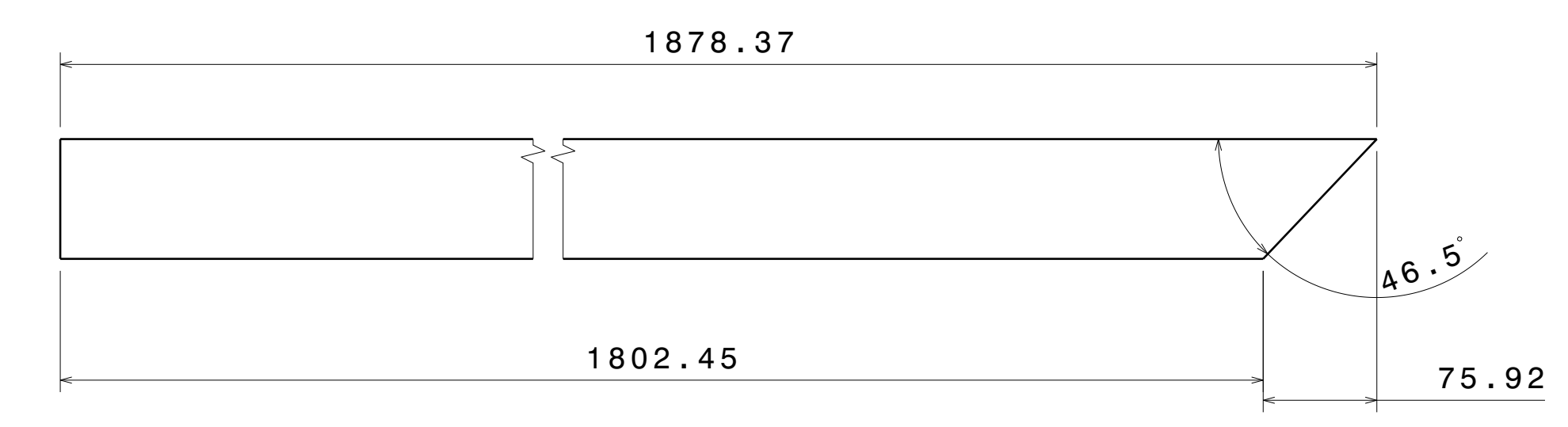

ITEM 3

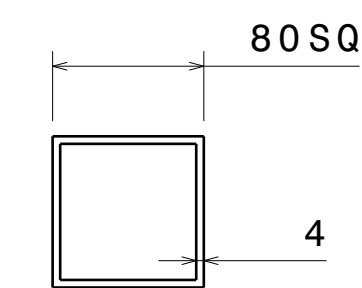

Right view[2]
Scale: 1:4

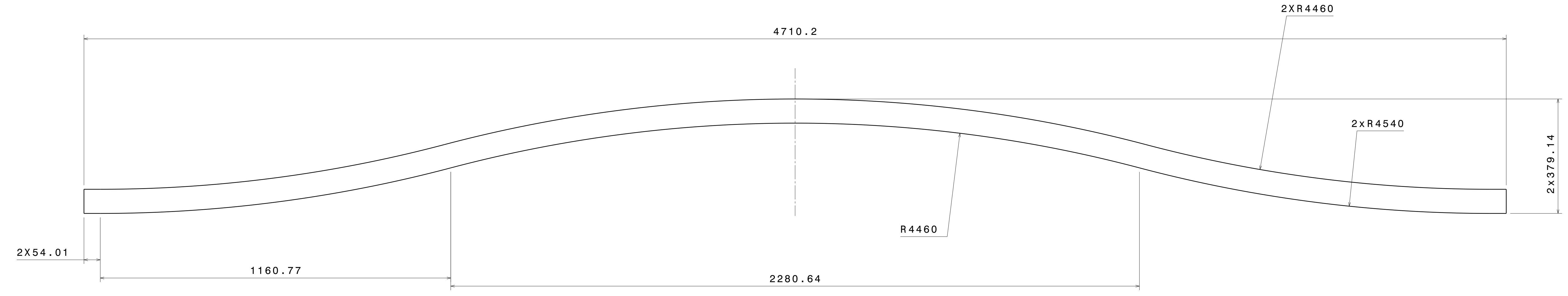

ITEM 4

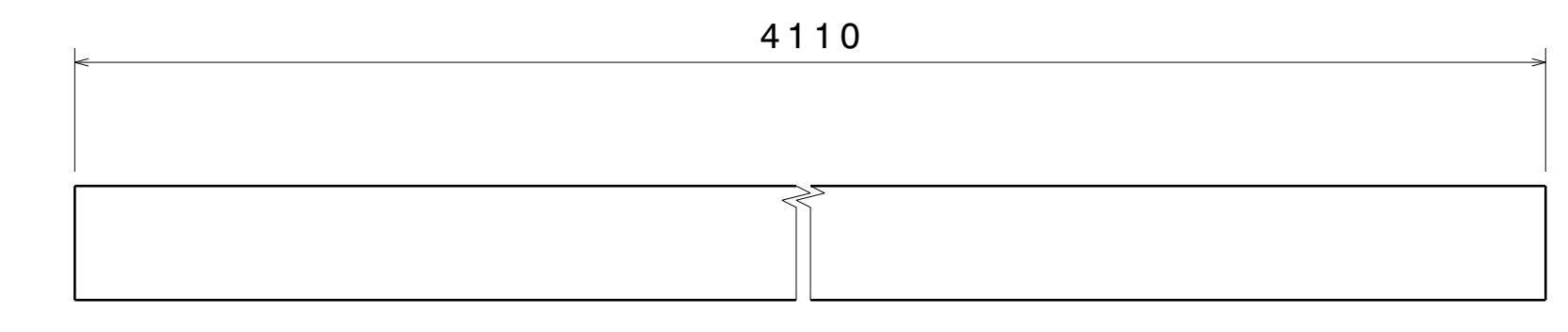

ITEM 5

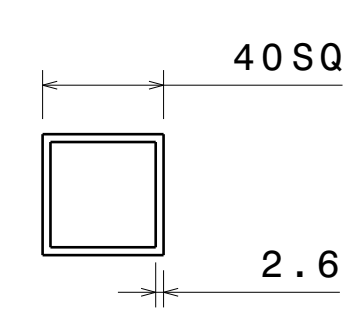

Right view
Scale: 2:5

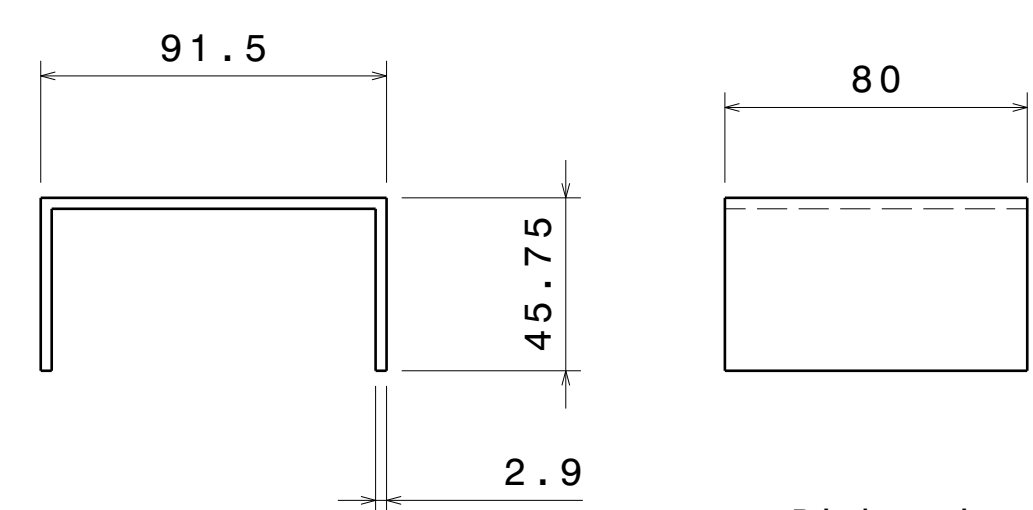

Right view
Scale: 1:2

ITEM 48 IS HALF OF SQUARE
CROSS SECTION
91.5 X 91.5 X 2.9.
SQUARE CROSS TO BE
SPLITTED AT MIDDLE ON ANY SIDE

UNLESS OTHERWISE SPECIFIED DIMENSION ARE IN MM
VIEWS: THIRD ANGLE PROJECTION

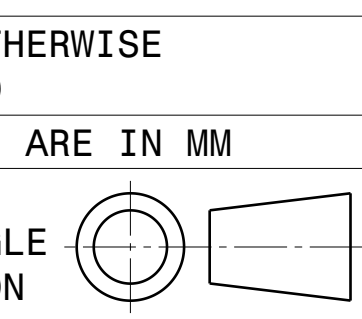

This drawing is our property. It can't be reproduced or communicated without our written agreement.		APL APOLLO TUBES LTD.	
DRAWN BY SB		DATE 2/26/2020	
CHECKED BY P2P Analysis & Solutions		DATE 2/26/2020	
DESIGNED BY P2P Analysis & Solutions		DATE 2/26/2020	
SIZE A0	DRAWING NUMBER P2P APL_00022	REV 00	
SCALE NONE	WEIGHT (kg) XXX	SHEET 3	

DRAWING TITLE
GATE 22

REV	DATE	DESCRIPTION
00	2/26/2020	INITIAL REVISION

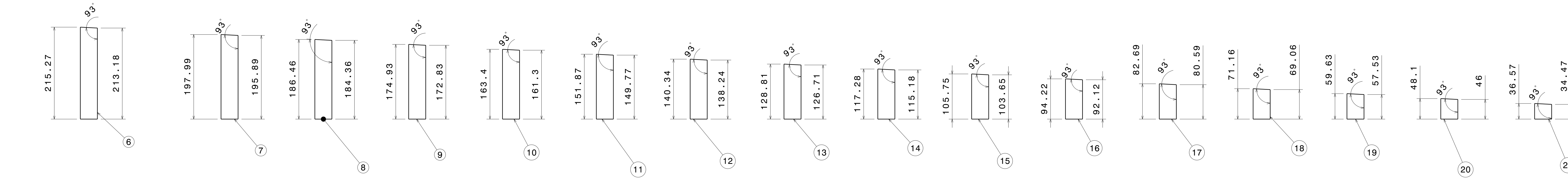

ITEM 6-21
CROSS SECTION: 40 X 40 X 2.6

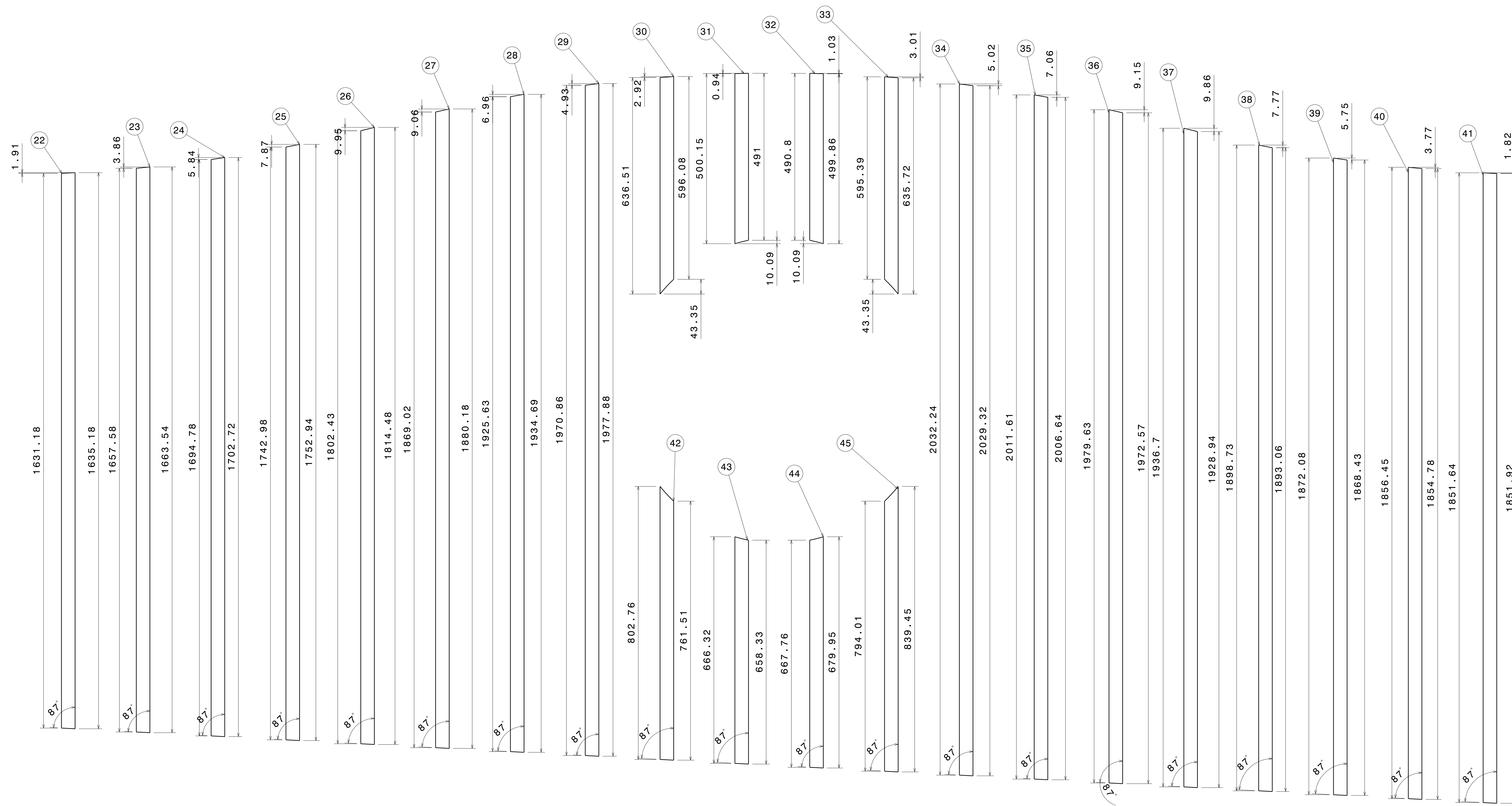

ITEM 22-45
CROSS SECTION: 40 X 40 X 2.6

UNLESS OTHERWISE SPECIFIED DIMENSION ARE IN MM VIEWS: THIRD ANGLE PROJECTION

This drawing is our property. It can't be reproduced or communicated without our written agreement.

DRAWN BY	DATE
SB	2/26/2020
CHECKED BY	DATE
P2P Analysis & Solutions	2/26/2020
DESIGNED BY	DATE
P2P Analysis & Solutions	2/26/2020

APL APOLLO TUBES LTD.	
DRAWING TITLE	
GATE 22	
SIZE	DRAWING NUMBER
A0	P2P APL_00022
SCALE	WEIGHT (kg)
NONE	XXX
SHEET	4