

1

2

3

4

5

6

A

A

B

B

C

C

D

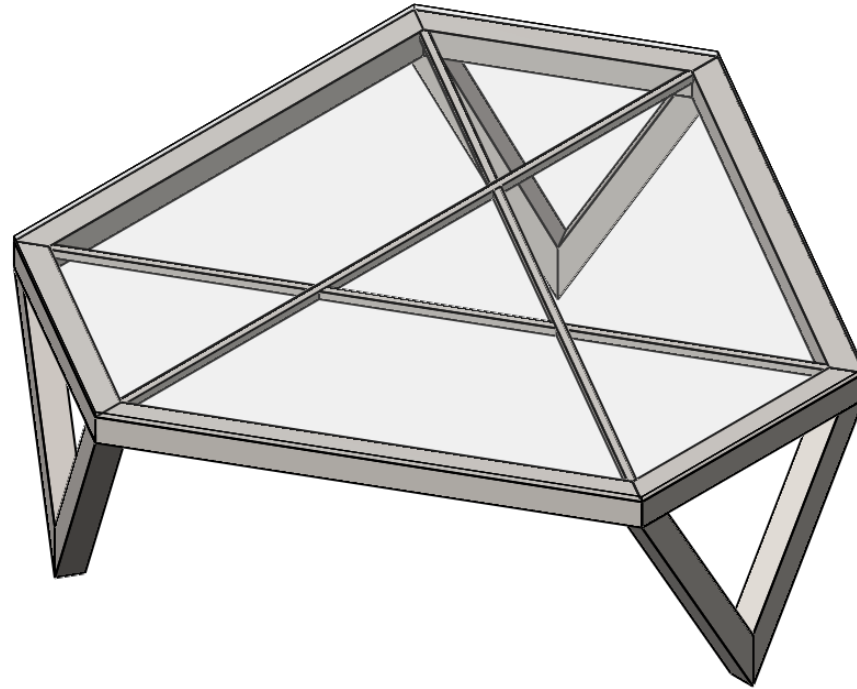

DO NOT SCALE DRAWING

REVISION

TITLE:

	NAME	SIGNATURE	DATE
DRAWN			
CHK'D			
APPVD			

DWG NO.

CENTER TABLE 1

SCALE:1:50

SHEET 1 OF 3

A4

1

2

3

A

B

C

D

A

B

C

D

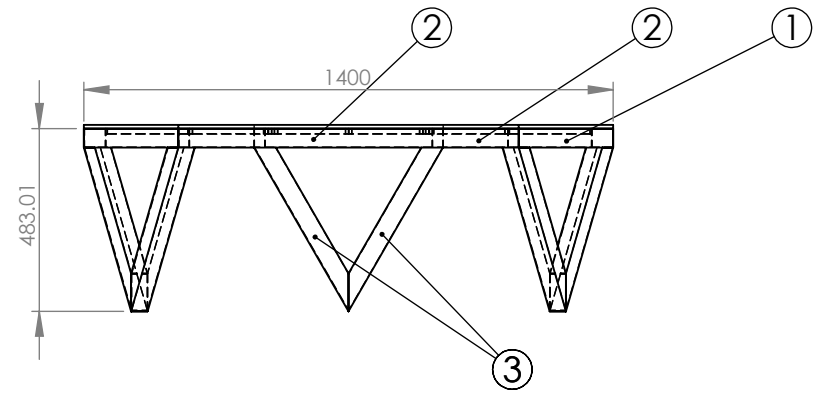
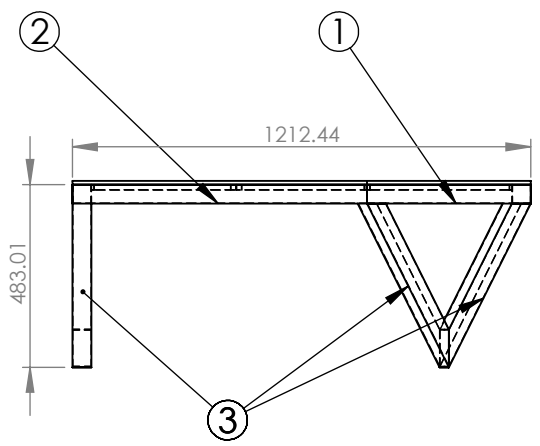
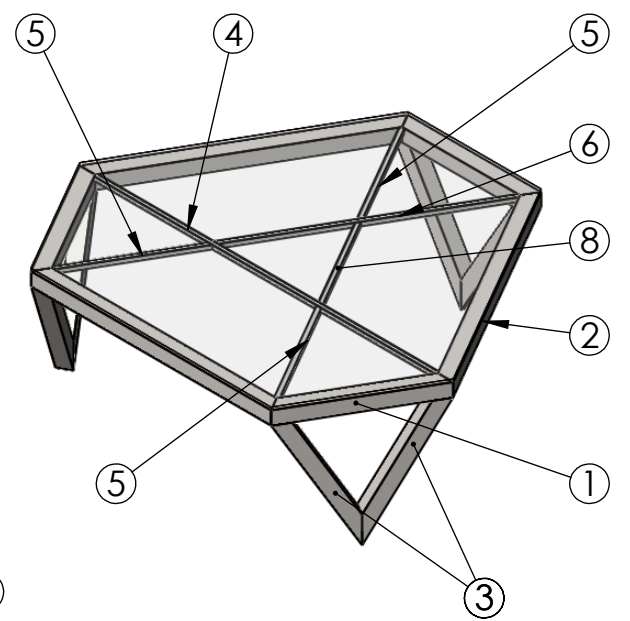
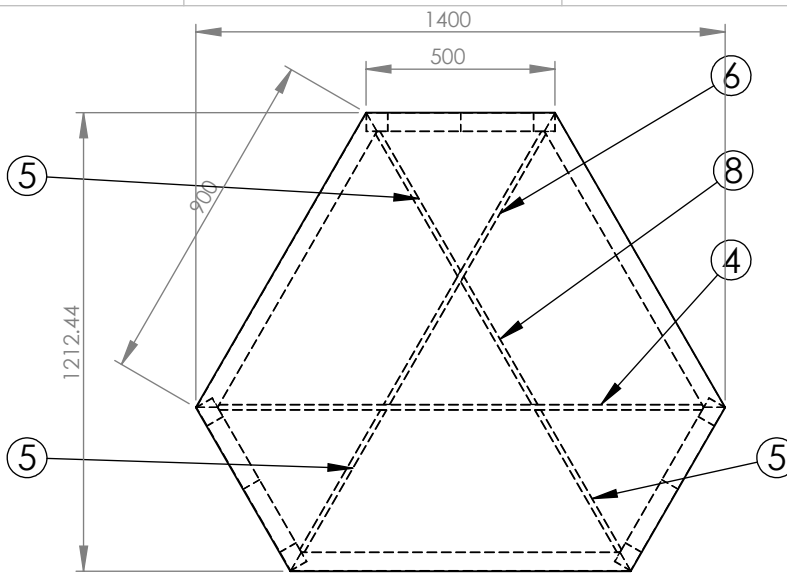

NOTE :-

- ALL VERTICAL AND HORIZONTAL SUPPORTS ARE PERFECTLY 90°.
- ∇∇ SURFACE FINISH, MEDIUM TO SMOOTH IS USED.
- ALL TUBES ARE AS PER APL APOLLO STANDARD.
- FINE WELDING IS REQUIRED AS PER MENTION DETAILS AND FINISHING.
- JOINTS ARE WELD TOGETHER BY THE HIGH ACCURACY MIG WELDING.
- ALL DIMENSIONS ARE IN MM.
- HIGHER CURRENT WELDING MAY EFFECT THE BRITTLENESS OF MATERIAL WHICH MAY RAISE TO WEAKENING OF STRUCTURE.

ITEM NO.	PART NUMBER	DESCRIPTION	QTY.	Unit
1	50X50X2.0X500	SHS	3	1500
2	50X50X2.0X900	SHS	3	2700
3	50X50X2.0X500 (2)	SHS	6	3000
4	15X15X1.2X1284.53	SHS	1	1284.53
5	15X15X1.2X437.86	SHS	3	1313.58
6	15X15X1.2X837.86	SHS	1	837.86
7	TOUGHENED GLASS 10mm THK.	GLASS	1	
8	15X15X1.2X391.26	SHS	1	391.26



DO NOT SCALE DRAWING

REVISION

	NAME	SIGNATURE	DATE	
DRAWN				DWG NO. CENTER TABLE 1
CHK'D				
APPVD				

SCALE:1:50

SHEET 2 OF 3

A4

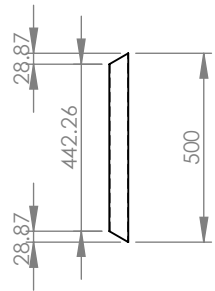

ITEM 1
SHS 50X50X2.0X500

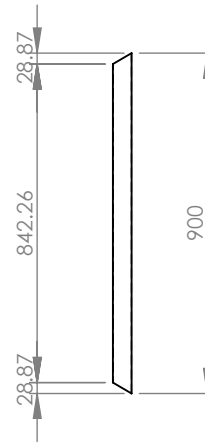

ITEM 2
SHS 50X50X2.0X900

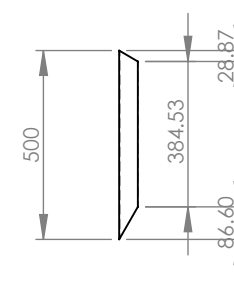

ITEM 3
SHS 50X50X2.0X500 (2)

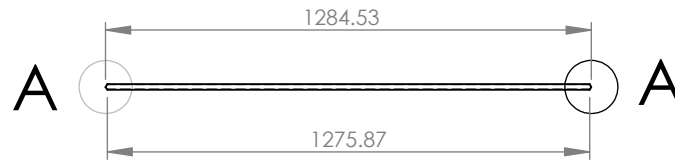

ITEM 4
SHS 15X15X1.2X1284.53

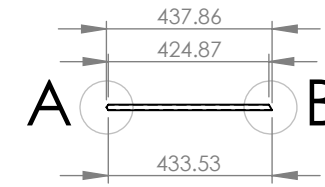
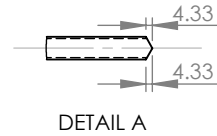

ITEM 5
SHS 15X15X1.2X437.86

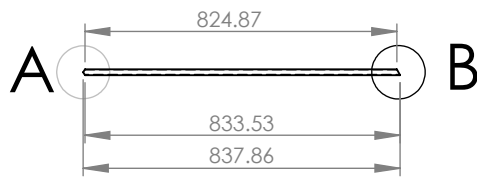

ITEM 6
SHS 15X15X1.2X837.86

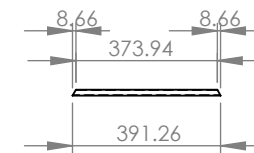
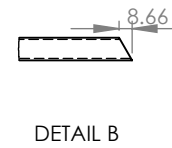

ITEM 8
SHS 15X15X1.2X391.26



DO NOT SCALE DRAWING

REVISION

TITLE:

PART DRAWINGS

	NAME	SIGNATURE	DATE
DRAWN			
CHK'D			
APP'VD			

DWG NO.

CENTER TABLE 1

SCALE:1:50

SHEET 3 OF 3

A4