				DO NOT SCALE DRAWING		REVISION
				TITLE:		
	NAME	SIGNATURE	DATE	DWG NO. CENTER TABLE 10		
DRAWN						
CHK'D						
APPVD				SCALE:1:50		SHEET 1 OF 3
						A4

A

B

C

D

A

B

C

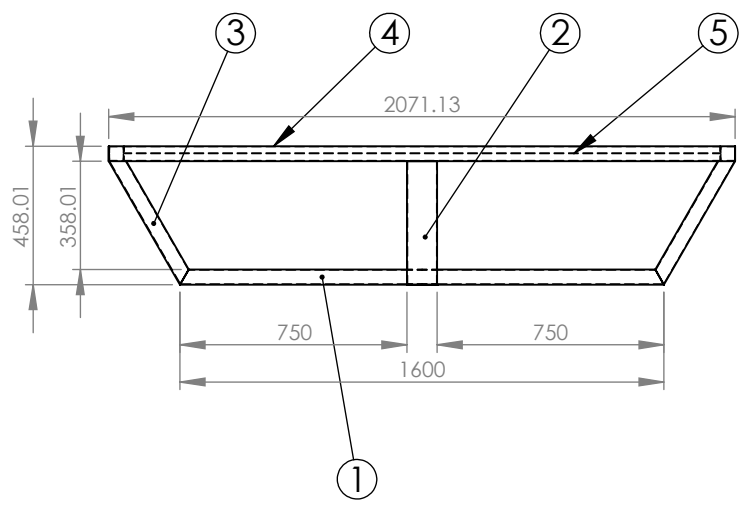
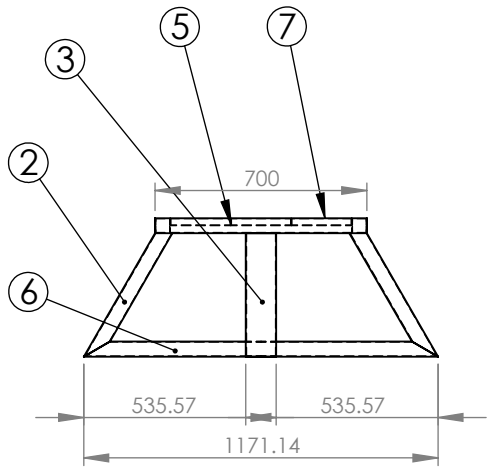
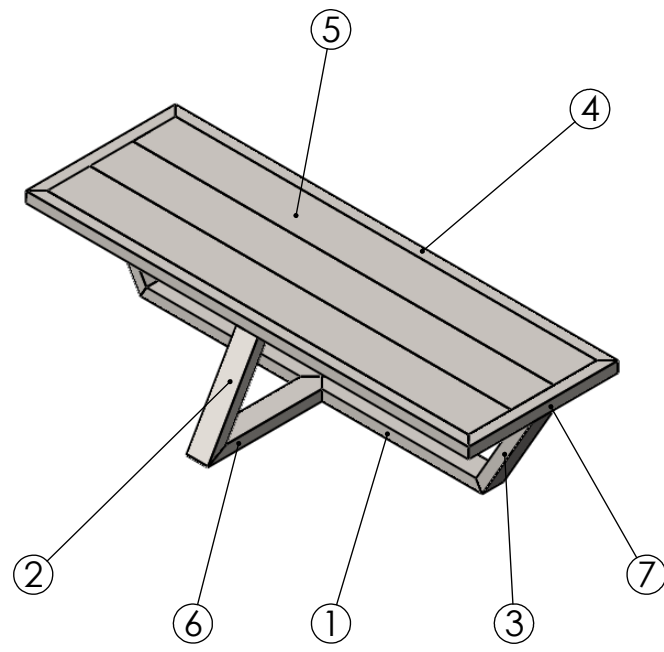
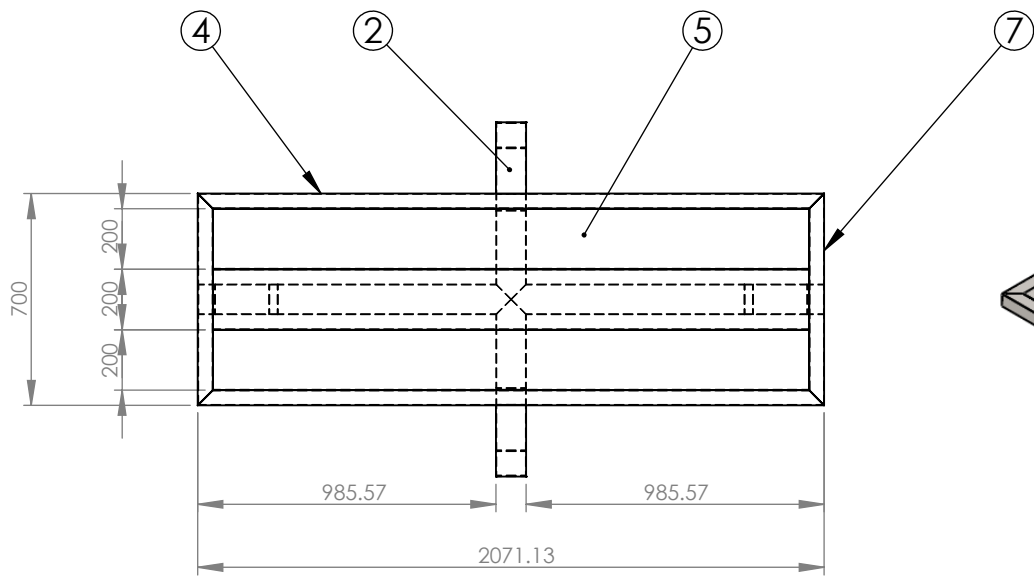

NOTE :-

- ALL VERTICAL AND HORIZONTAL SUPPORTS ARE PERFECTLY 90°.
- ∇∇ SURFACE FINISH, MEDIUM TO SMOOTH IS USED.
- ALL TUBES ARE AS PER APL APOLLO STANDARD.
- FINE WELDING IS REQUIRED AS PER MENTION DETAILS AND FINISHING.
- JOINTS ARE WELD TOGETHER BY THE HIGH ACCURACY MIG WELDING.
- ALL DIMENSIONS ARE IN MM.
- HIGHER CURRENT WELDING MAY EFFECT THE BRITTLENESS OF MATERIAL WHICH MAY RAISE TO WEAKENING OF STRUCTURE.

ITEM NO.	PART NUMBER	DESCRIPTION	QTY.	Unit
1	100X50X2.0X800	RHS	2	1600
2	100X50X2.0X500 (2)	RHS	2	1000
3	100X50X2.0X471.13	RHS	2	942.26
4	50X50X2.0X2071.13	SHS	2	4142.26
5	PLANK 200X25X2.0X1971.13	SHS	3	5913.39
6	100X50X2.0X585.57	RHS	2	1171.14
7	50X50X2.0X700	SHS	2	1400



DO NOT SCALE DRAWING

REVISION

	NAME	SIGNATURE	DATE	
DRAWN				DWG NO. CENTER TABLE 10
CHK'D				
APPV'D				

SCALE:1:50

SHEET 2 OF 3

A4

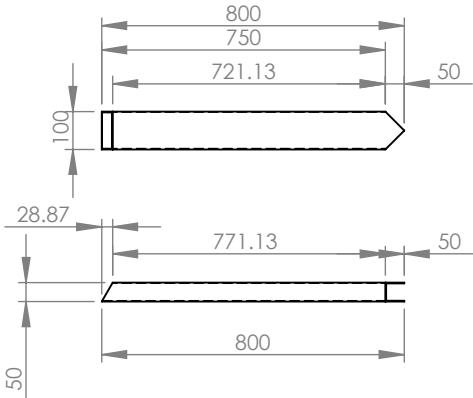

ITEM 1
RHS 100X50X2.0X800

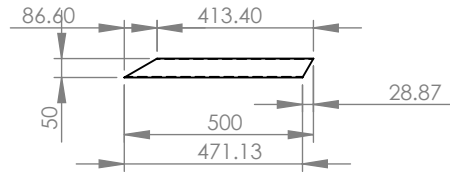

ITEM 2
RHS 100X50X2.0X500 (2)

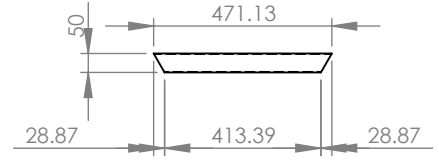

ITEM 3
RHS 100X50X2.0X471.13

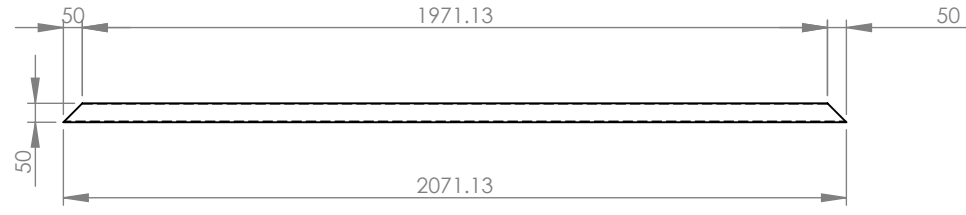

ITEM 4
SHS 500X50X2.0X2071.13

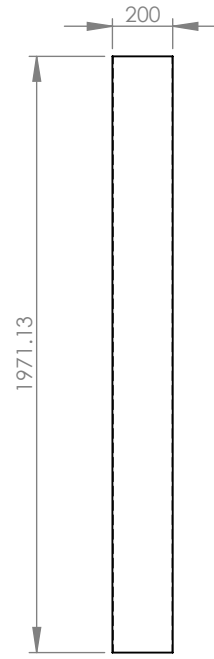

ITEM 5
PLANK 250X25X2.0X1971.13

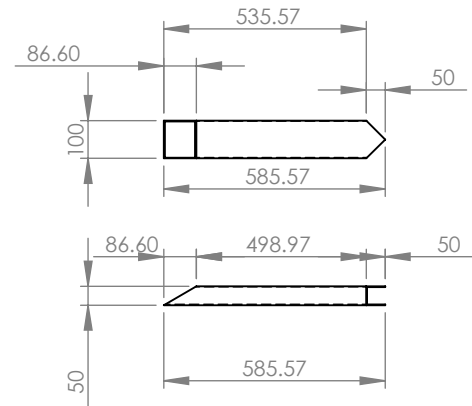

ITEM 6
RHS 100X50X2.0X585.57

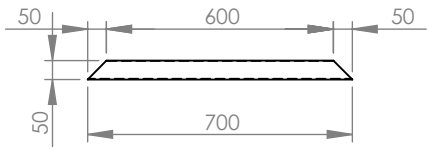

ITEM 7
SHS 500X50X2.0X700

			DO NOT SCALE DRAWING		REVISION	
			TITLE: PART DRAWINGS			
DRAWN			DWG NO.		CENTER TABLE 10	
CHK'D			SCALE:1:50		SHEET 3 OF 3	
APPVD					A4	