			DO NOT SCALE DRAWING		REVISION
			TITLE:		
	NAME	SIGNATURE	DATE	DWG NO. CENTER TABLE 11	
DRAWN					
CHK'D					
APPVD				SCALE:1:50	SHEET 1 OF 3

NOTE :-

- ALL VERTICAL AND HORIZONTAL SUPPORTS ARE PERFECTLY 90°.
- ∇ SURFACE FINISH, MEDIUM TO SMOOTH IS USED.
- ALL TUBES ARE AS PER APL APOLLO STANDARD.
- FINE WELDING IS REQUIRED AS PER MENTION DETAILS AND FINISHING.
- JOINTS ARE WELD TOGETHER BY THE HIGH ACCURACY MIG WELDING.
- ALL DIMENSIONS ARE IN MM.
- HIGHER CURRENT WELDING MAY EFFECT THE BRITTLNESS OF MATERIAL WHICH MAY RAISE TO WEAKENING OF STRUCTURE.

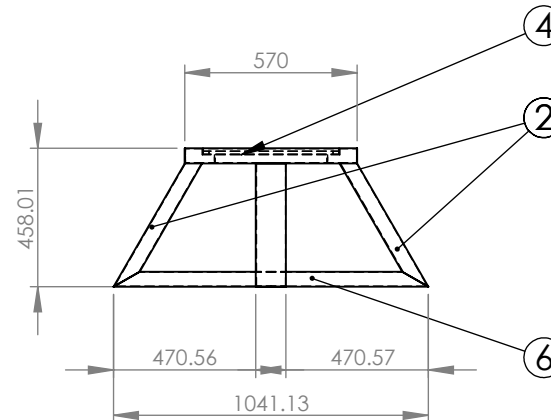

ITEM NO.	PART NUMBER	DESCRIPTION	QTY.	Unit
1	100X50X2.0X800	RHS	2	1600
2	100X50X2.0X500 (2)	RHS	2	1000
3	SDF 100X50X2.0X2071.13	SDF	2	4142.26
4	SDF 100X50X2.0X570	SDF	2	1140
5	100X50X2.0X471.13	RHS	2	942.26
6	100X50X2.0X520.57	RHS	2	1041.14
7	RUBBER 1951.13	SHS	2	
8	RUBBER 450	SHS	2	
9	TOUGHENED GLASS 1951.13X450X10	SHS	1	

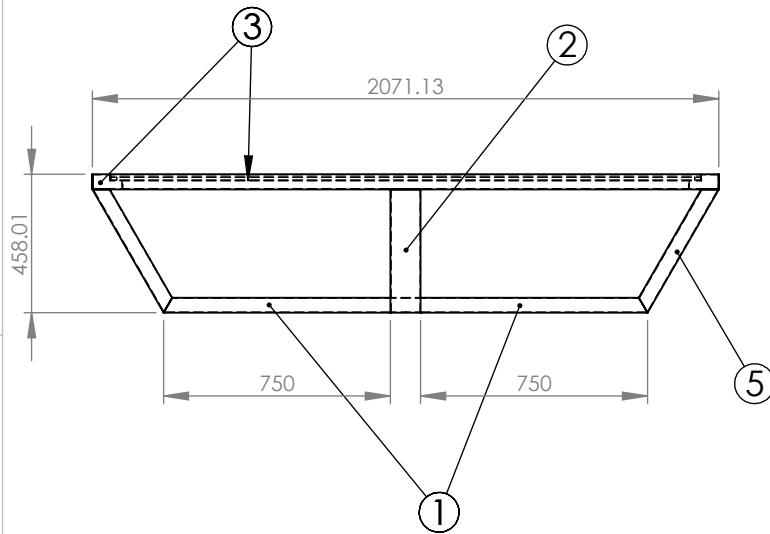
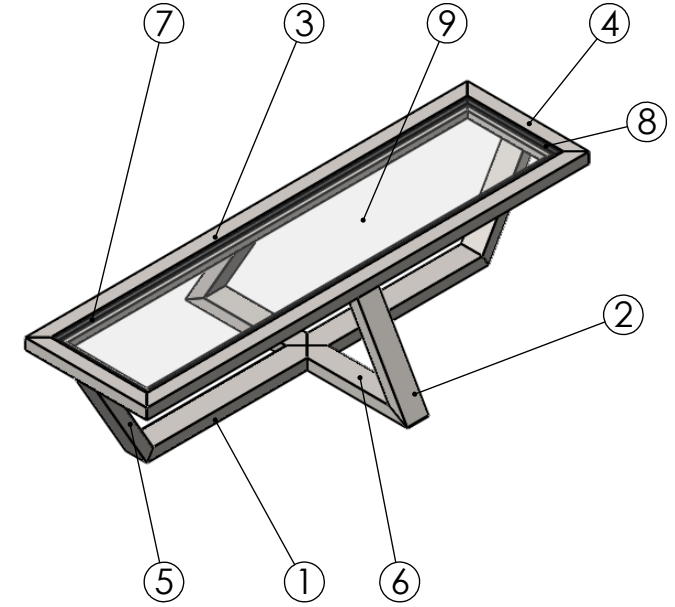
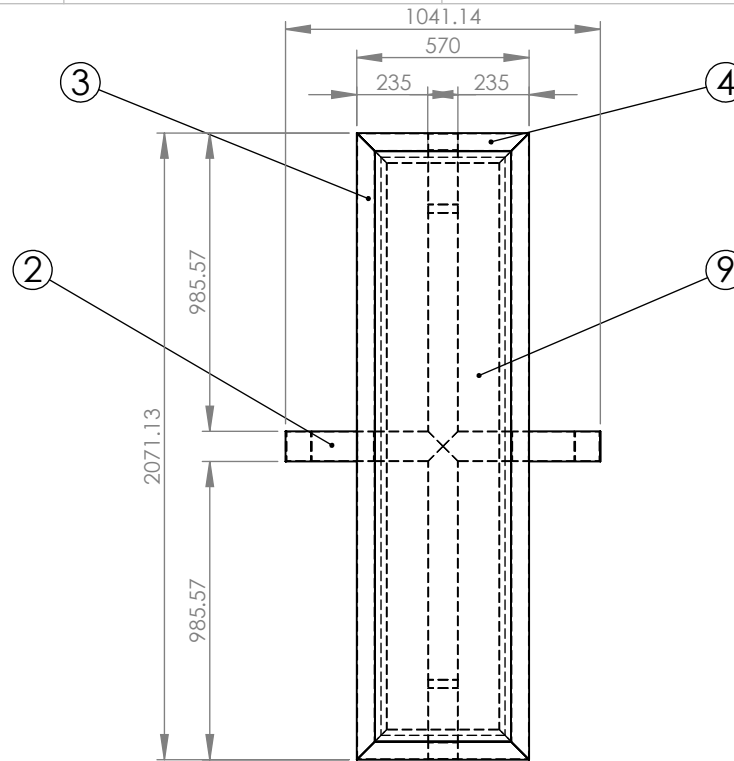

	NAME	SIGNATURE	DATE
DRAWN			
CHK'D			
APPVD			

DO NOT SCALE DRAWING

REVISION

TITLE:

DWG NO.

CENTER TABLE 11

SCALE:1:50

SHEET 2 OF 3

A4

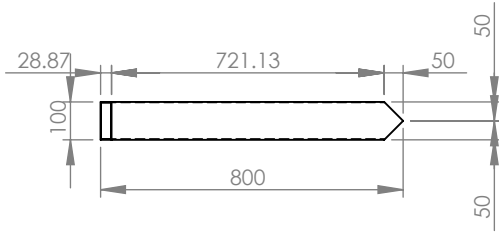

ITEM 1
RHS 100X50X2.0X800

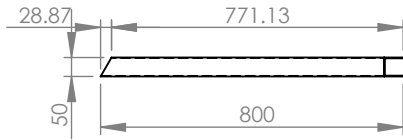

ITEM 2
RHS 100X50X2.0X500 (2)

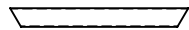

ITEM 5
RHS 100X50X2.0X471.13

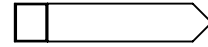

ITEM 6
RHS 100X50X2.0X520.57

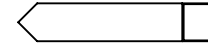

ITEM 3
SDF 100X50X2.0X2071.13

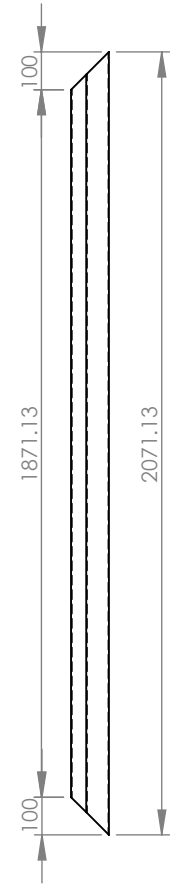
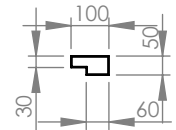

DO NOT SCALE DRAWING

REVISION

TITLE:

PART DRAWINGS

	NAME	SIGNATURE	DATE
DRAWN			
CHK'D			
APPVD			

DWG NO.

CENTER TABLE 11

SCALE:1:50

SHEET 3 OF 3

A4