

1

2

3

4

5

6

A

A

B

B

C

C

D

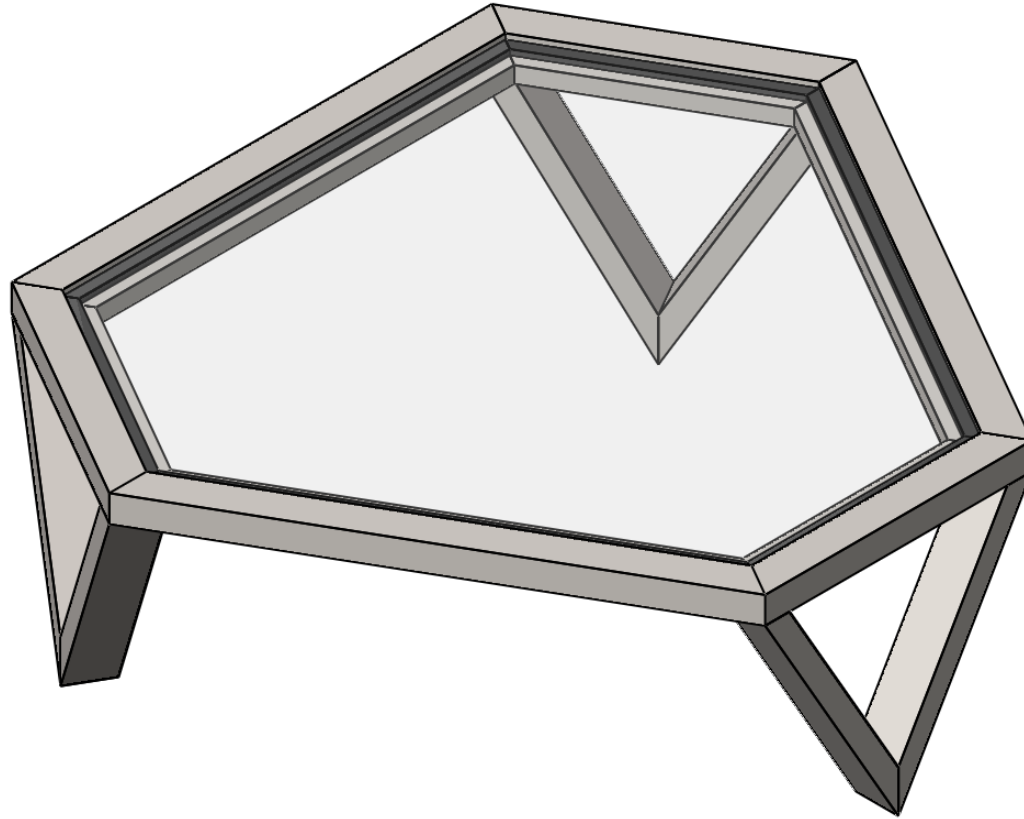

			DO NOT SCALE DRAWING		REVISION
			TITLE:		
	NAME	SIGNATURE	DATE	DWG NO. <b>CENTER TABLE 2</b>	
DRAWN					
CHK'D					
APPVD				SCALE:1:20	SHEET 1 OF 3

1

2

3

A4

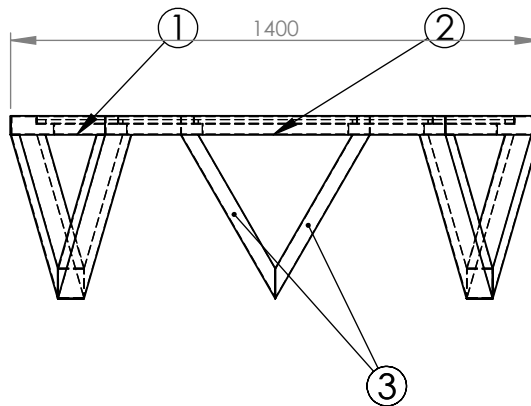
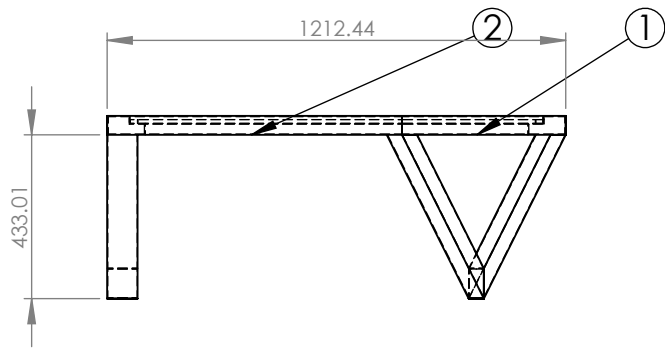
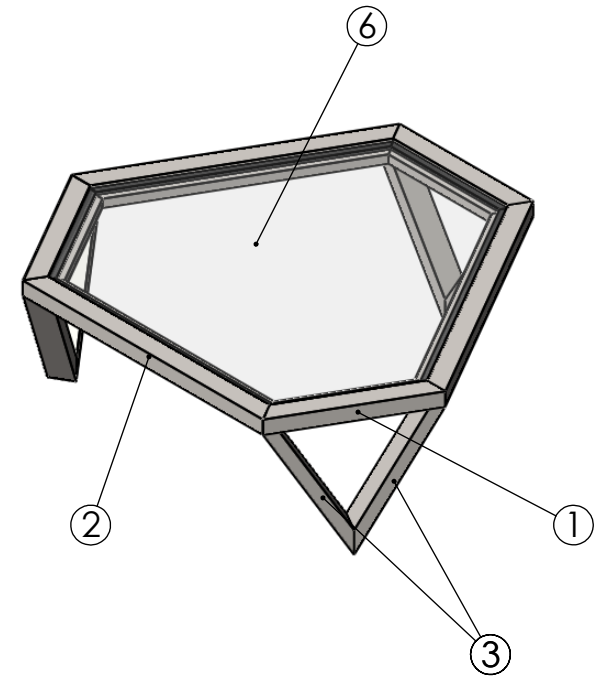
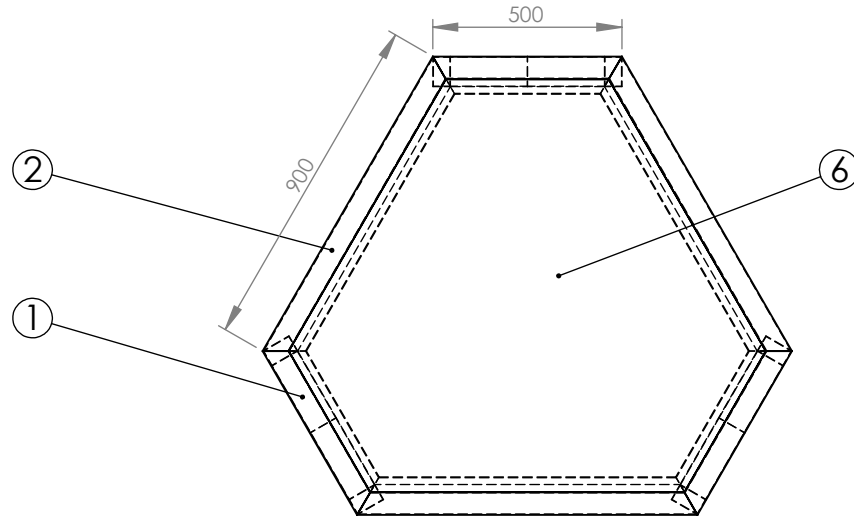

**NOTE :-**

- ALL VERTICAL AND HORIZONTAL SUPPORTS ARE PERFECTLY 90°.
- ∇∇ SURFACE FINISH, MEDIUM TO SMOOTH IS USED.
- ALL TUBES ARE AS PER APL APOLLO STANDARD.
- FINE WELDING IS REQUIRED AS PER MENTION DETAILS AND FINISHING.
- JOINTS ARE WELD TOGETHER BY THE HIGH ACCURACY MIG WELDING.
- ALL DIMENSIONS ARE IN MM.
- HIGHER CURRENT WELDING MAY EFFECT THE BRITTLINESS OF MATERIAL WHICH MAY RAISE TO WEAKENING OF STRUCTURE.

ITEM NO.	PART NUMBER	DESCRIPTION	QTY.	LENGTH
1	SDF 100X50X2.0X500	SDF	3	1500
2	SDF 100X50X2.0X900	SDF	3	1800
3	80X40X2.0X500	RHS	6	3000
4	RUBBER 20X10X430.72	RUBBER	3	
5	RUBBER 20X10X830.72	RUBBER	3	
6	TOUGHENED GLASS (2) 10mm THK.	GLASS	1	



DO NOT SCALE DRAWING			REVISION
TITLE:			
NAME	SIGNATURE	DATE	
DRAWN			
CHK'D			
APPVD			
DWG NO.		CENTER TABLE 2	
SCALE:1:20		SHEET 2 OF 3	

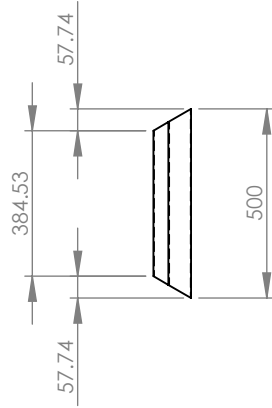

ITEM 1  
SDF 100X50X2.0X500

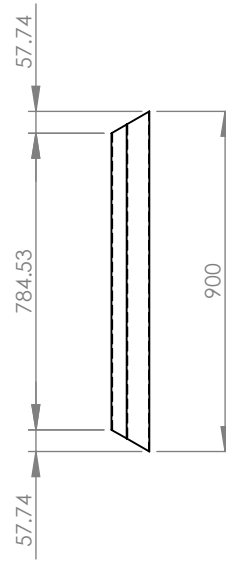

ITEM 2  
SDF 100X50X2.0X900

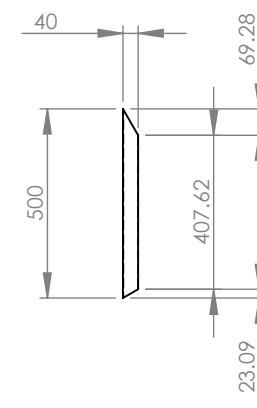

ITEM 3  
RHS 80X40X2.0X500



DO NOT SCALE DRAWING

REVISION

TITLE:

PART DRAWINGS

	NAME	SIGNATURE	DATE
DRAWN			
CHK'D			
APPVD			

DWG NO.

CENTER TABLE 2

SCALE:1:20

SHEET 3 OF 3

A4