

1 2 3 4 5 6

A

A

B

B

C

C

D

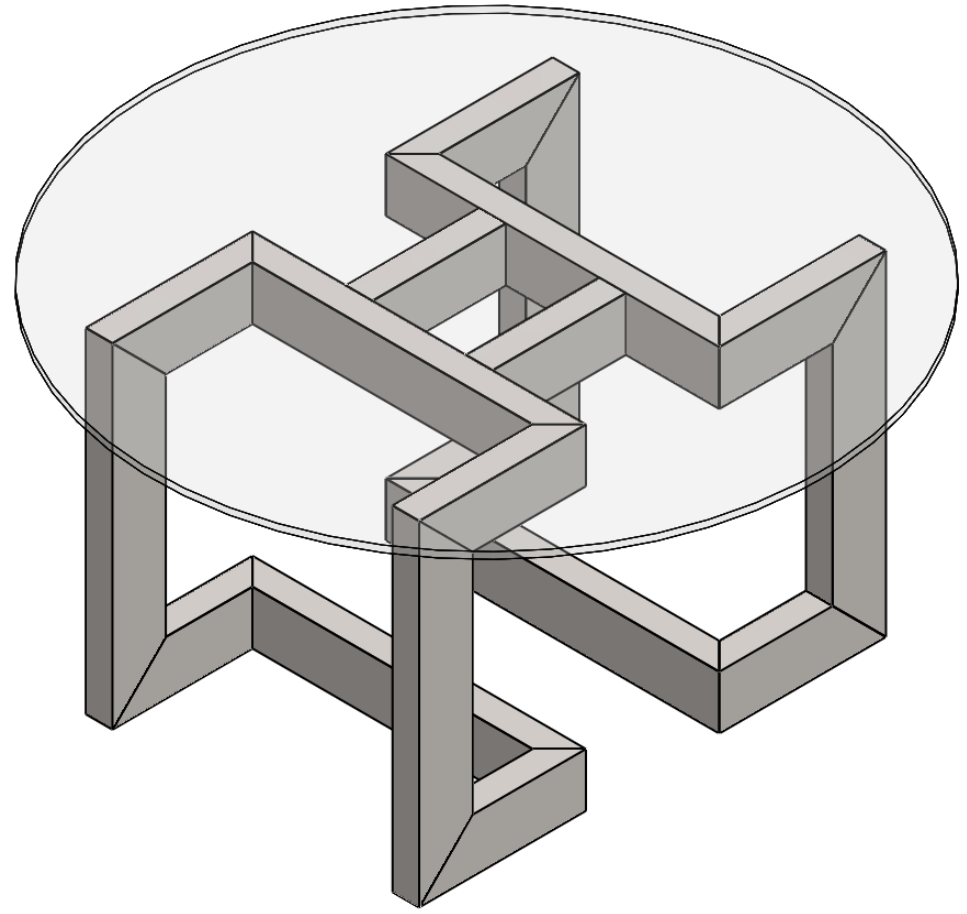

DO NOT SCALE DRAWING	REVISION
----------------------	----------

TITLE:	
--------	--

	NAME	SIGNATURE	DATE
DRAWN			
CHK'D			
APPVD			

DWG NO.	CENTER TABLE 4
---------	----------------

1 2 3 4 5 6

SCALE:1:20	SHEET 1 OF 3	A4
------------	--------------	----

NOTE :-

- ALL VERTICAL AND HORIZONTAL SUPPORTS ARE PERFECTLY 90°.
- ∇ SURFACE FINISH, MEDIUM TO SMOOTH IS USED.
- ALL TUBES ARE AS PER APL APOLLO STANDARD.
- FINE WELDING IS REQUIRED AS PER MENTION DETAILS AND FINISHING.
- JOINTS ARE WELD TOGETHER BY THE HIGH ACCURACY MIG WELDING.
- ALL DIMENSIONS ARE IN MM.
- HIGHER CURRENT WELDING MAY EFFECT THE BRITTLINESS OF MATERIAL WHICH MAY RAISE TO WEAKENING OF STRUCTURE.

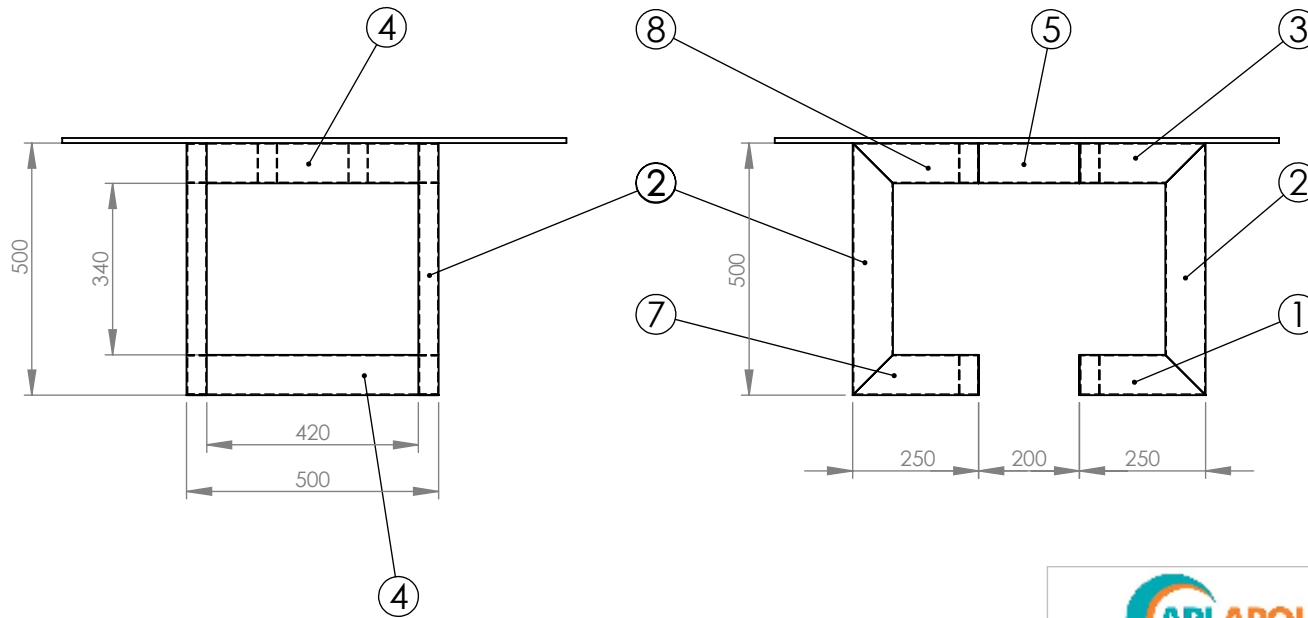
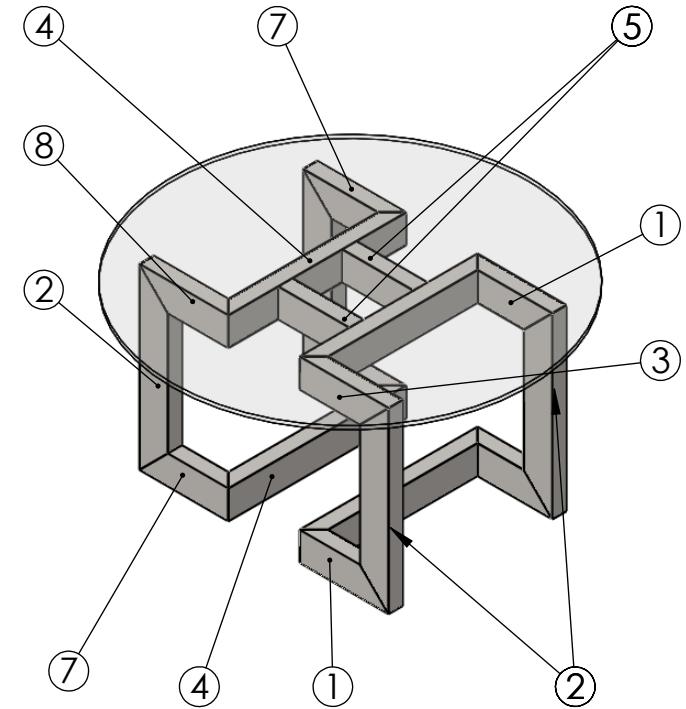
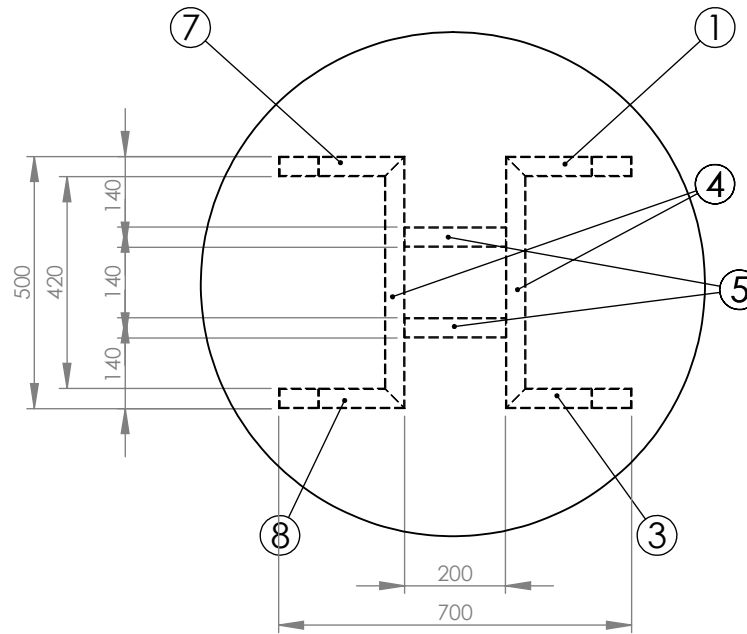

ITEM NO.	PART NUMBER	DESCRIPTION	QTY.	LENGTH
1	80X40X2X250	RHS	2	500
2	80X40X2X500	RHS	4	2000
3	80X40X2X250 (2)	RHS	2	500
4	80X40X2X500 (2)	RHS	4	2000
5	80X40X2X200	RHS	2	400
6	TOUGHENED GLASS	GLASS	1	
7	80X40X2X250 (4)	RHS	2	500
8	80X40X2X250 (3)	RHS	2	500



DO NOT SCALE DRAWING

REVISION

TITLE:

NAME SIGNATURE DATE

DRAWN

CHK'D

APPVD

DWG NO.

CENTER TABLE 4

SCALE:1:20

SHEET 2 OF 3

A4

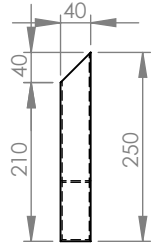

ITEM 1
RHS 80X40X2.0X250

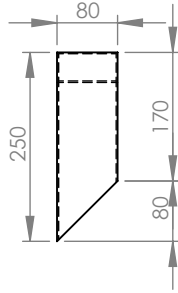

ITEM 2
RHS 80X40X2.0X500

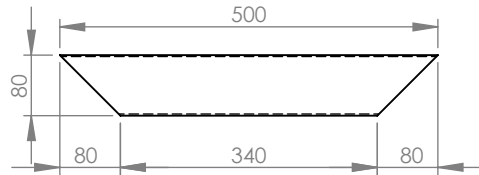

ITEM 3
RHS 80X40X2.0X250 (2)

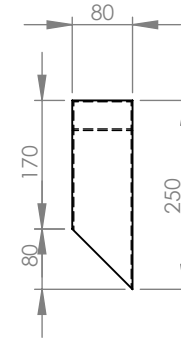

ITEM 4
RHS 80X40X2.0X500 (2)

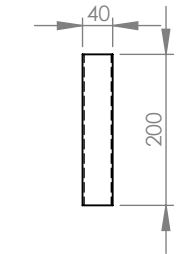
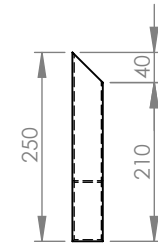

ITEM 4
RHS 80X40X2.0X200

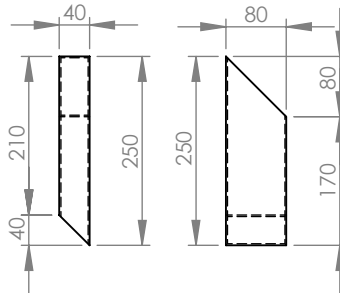

ITEM 5
RHS 80X40X2.0X250 (4)

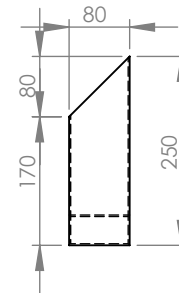

ITEM 6
RHS 80X40X2.0X250 (3)

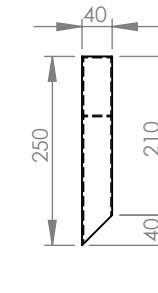

DO NOT SCALE DRAWING

REVISION

TITLE:

PART DRAWINGS

	NAME	SIGNATURE	DATE
DRAWN			
CHK'D			
APPVD			

DWG NO.

CENTER TABLE 4

SCALE:1:20

SHEET 3 OF 3

A4