

A

A

B

B

C

C

D

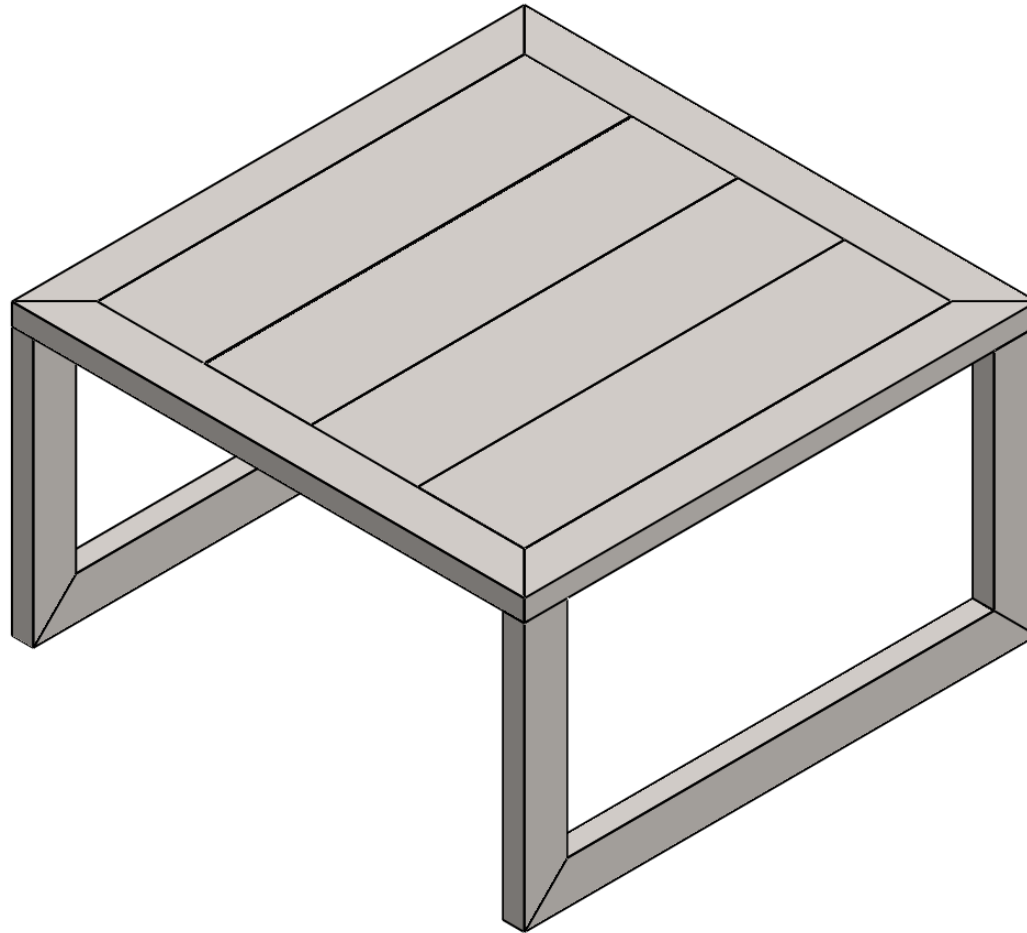

1

2

3

4

5

6

1

2

3

			DO NOT SCALE DRAWING		REVISION
			TITLE:		
	NAME	SIGNATURE	DATE	DWG NO. <b>CENTER TABLE 5</b>	
DRAWN					
CHK'D					
APPVD				SCALE:1:20	SHEET 1 OF 3
				<b>A4</b>	

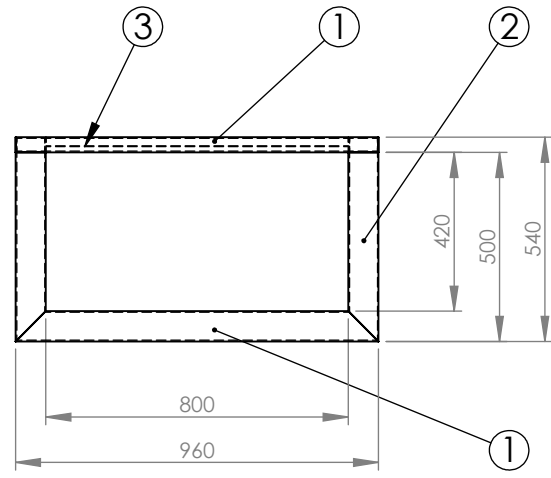
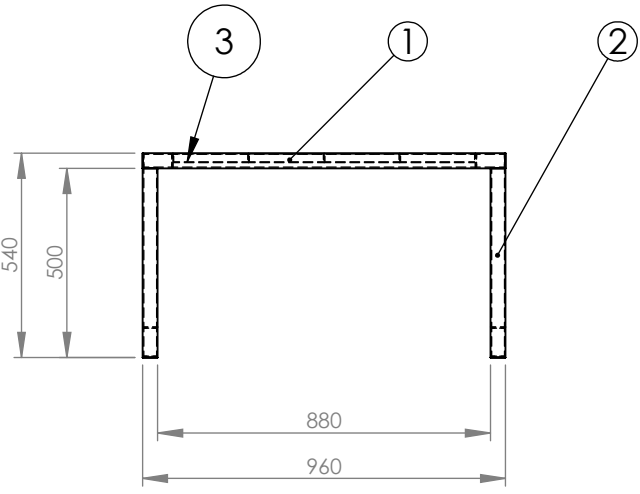
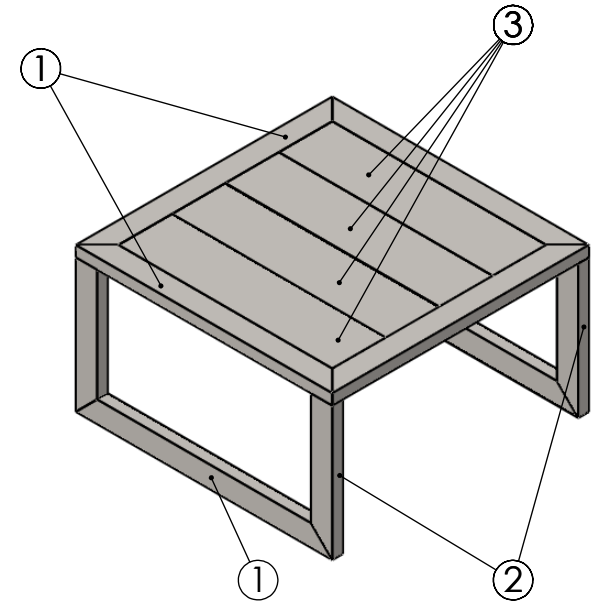
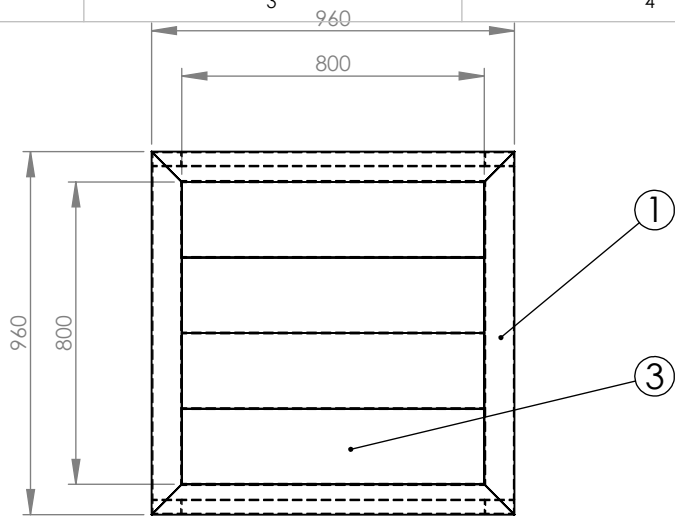

**NOTE :-**

- ALL VERTICAL AND HORIZONTAL SUPPORTS ARE PERFECTLY 90°.
- ∇∇ SURFACE FINISH, MEDIUM TO SMOOTH IS USED.
- ALL TUBES ARE AS PER APL APOLLO STANDARD.
- FINE WELDING IS REQUIRED AS PER MENTION DETAILS AND FINISHING.
- JOINTS ARE WELD TOGETHER BY THE HIGH ACCURACY MIG WELDING.
- ALL DIMENSIONS ARE IN MM.
- HIGHER CURRENT WELDING MAY EFFECT THE BRITTLINESS OF MATERIAL WHICH MAY RAISE TO WEAKENING OF STRUCTURE.

ITEM NO.	PART NUMBER	DESCRIPTION	QTY.	Unit
1	80X40X3X960	RHS	6	5760
2	80X40X3X500	RHS	4	2000
3	PLANK 200X25X2.0X800	RHS	4	3200



DO NOT SCALE DRAWING			REVISION
TITLE:			
DRAWN	NAME	SIGNATURE	DATE
CHK'D			
APPV'D			
DWG NO.		CENTER TABLE 5	
SCALE:1:20		SHEET 2 OF 3	

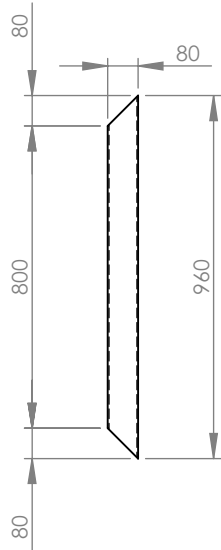

ITEM 1  
RHS 80X40X3.0X960

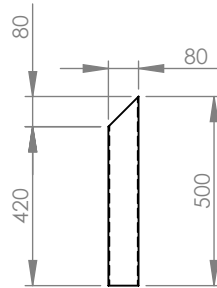

ITEM 2  
RHS 80X40X3.0X500

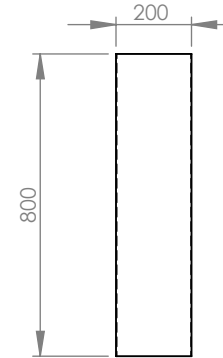

ITEM 3  
PLANK 200X25X2.0X800



DO NOT SCALE DRAWING

REVISION

TITLE:

PART DRAWINGS

	NAME	SIGNATURE	DATE
DRAWN			
CHK'D			
APPVD			

DWG NO.

CENTER TABLE 5

SCALE:1:20

SHEET 3 OF 3

A4