

1

2

3

4

5

6

A

A

B

B

C

C

D

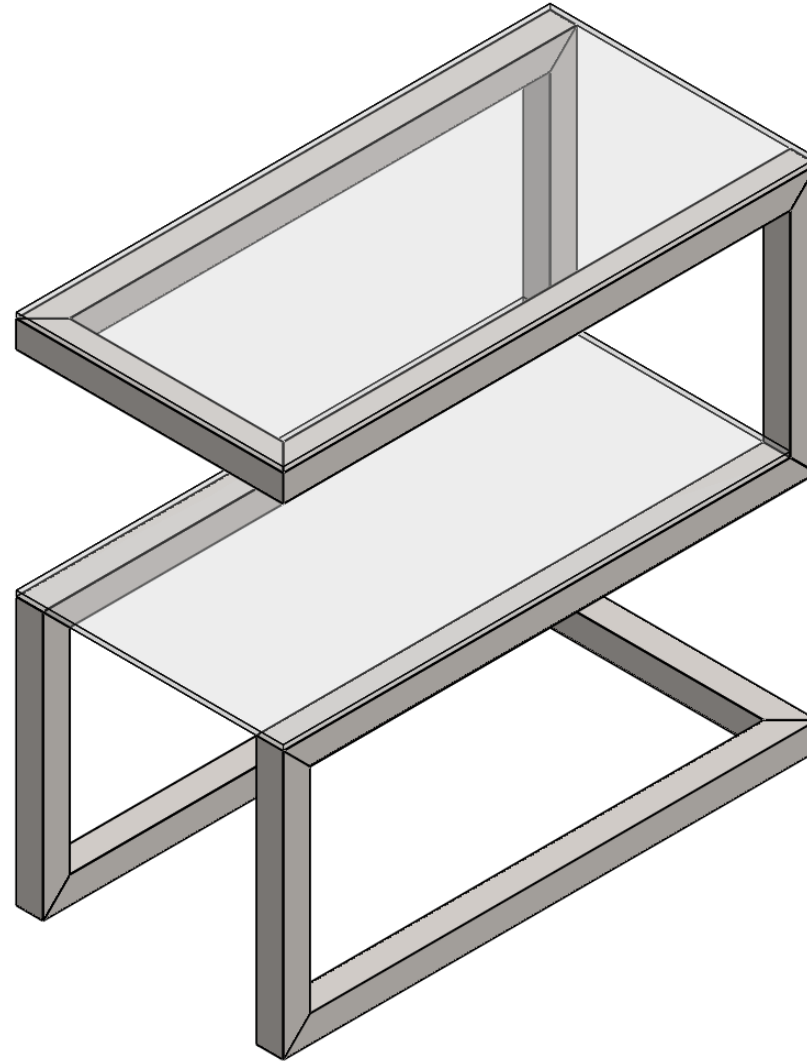

DO NOT SCALE DRAWING

REVISION

TITLE:

	NAME	SIGNATURE	DATE
DRAWN			
CHK'D			
APPVD			

DWG NO.

SIDE TABLE 1

SCALE:1:20

SHEET 1 OF 3

A4

1

2

3

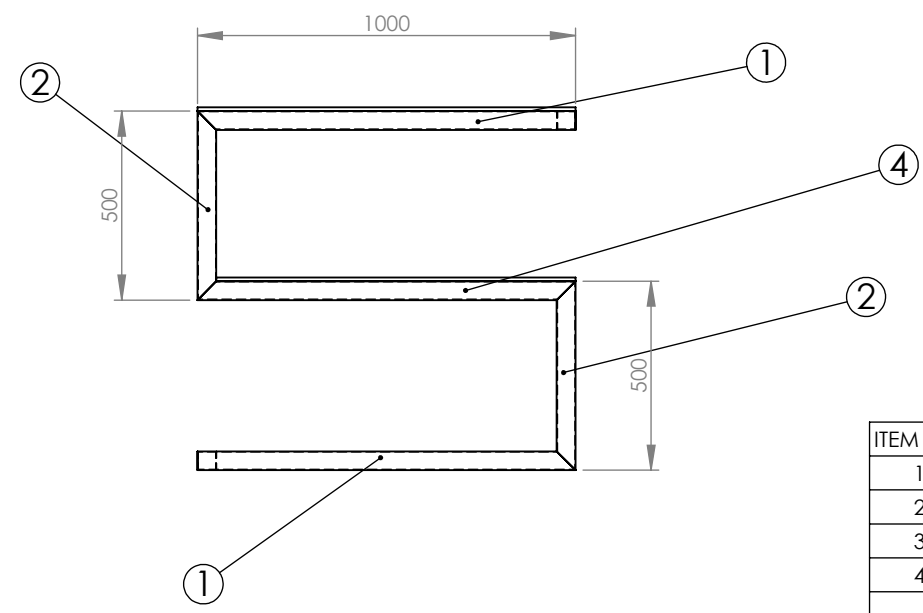
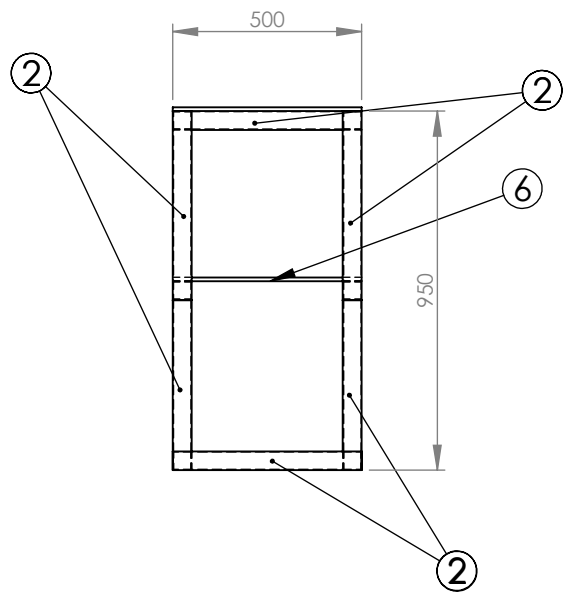
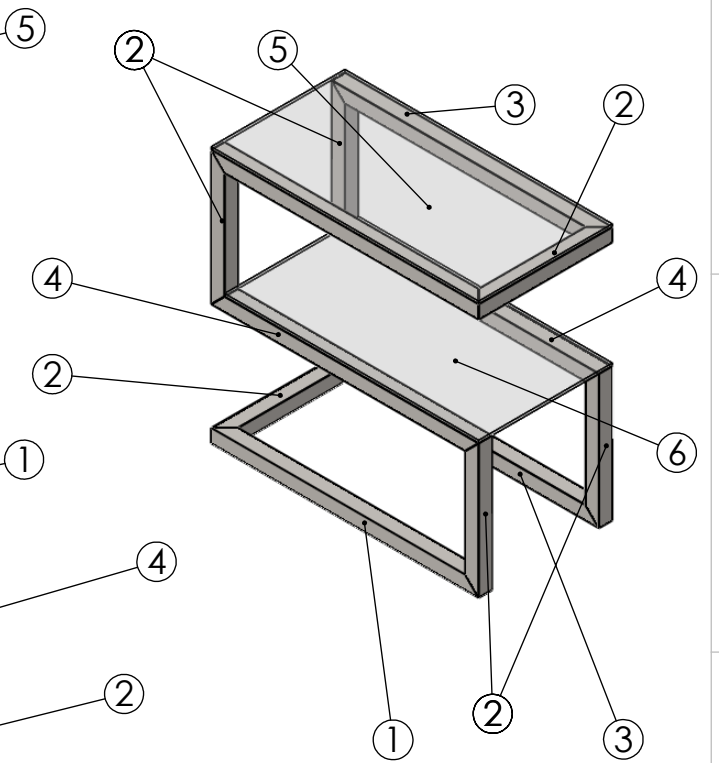
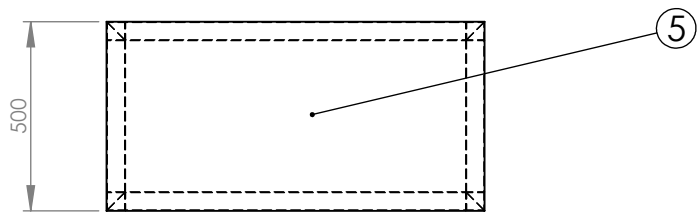

ITEM NO.	PART NUMBER	DESCRIPTION	QTY.	Unit
1	50X50X2X1000	SHS	2	2000
2	50X50X2X500	SHS	6	3000
3	50X50X2X1000 (3)	SHS	2	2000
4	50X50X2X1000 (2)	SHS	2	2000
5	TOUGHENED GLASS 1000X500X10		1	
6	TOUGHENED GLASS 950X500X10		1	

NOTE :-

- ALL VERTICAL AND HORIZONTAL SUPPORTS ARE PERFECTLY 90°.
- ∇∇ SURFACE FINISH, MEDIUM TO SMOOTH IS USED.
- ALL TUBES ARE AS PER APL APOLLO STANDARD.
- FINE WELDING IS REQUIRED AS PER MENTION DETAILS AND FINISHING.
- JOINTS ARE WELD TOGETHER BY THE HIGH ACCURACY MIG WELDING.
- ALL DIMENSIONS ARE IN MM.
- HIGHER CURRENT WELDING MAY EFFECT THE BRITTLENESS OF MATERIAL WHICH MAY RAISE TO WEAKENING OF STRUCTURE.

DO NOT SCALE DRAWING

REVISION

NAME	SIGNATURE	DATE	TITLE:
			<p>DWG NO. SIDE TABLE 1</p>
DRAWN			
CHK'D			
APPVD			

SCALE:1:20

SHEET 2 OF 3

A4

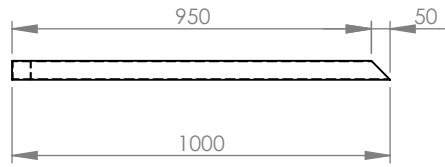

ITEM 1
SHS 50X50X2.0X1000

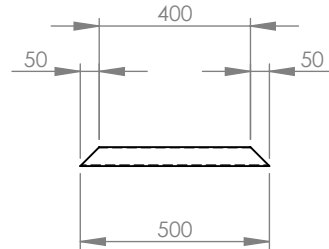
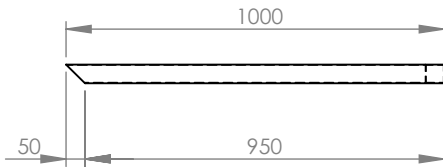

ITEM 2
SHS 50X50X2.0X500

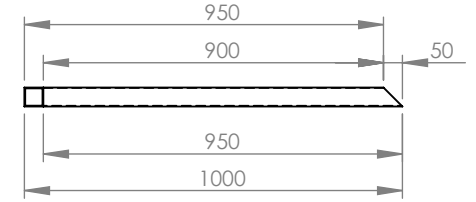

ITEM 3
SHS 50X50X2.0X1000 (3)

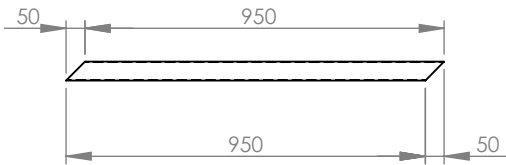
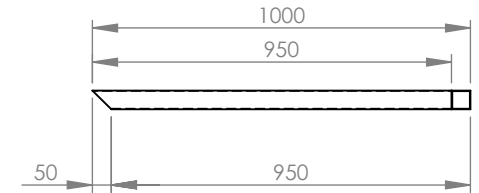

ITEM 4
SHS 50X50X2.0X1000 (2)



DO NOT SCALE DRAWING

REVISION

TITLE:

PART DRAWINGS

	NAME	SIGNATURE	DATE
DRAWN			
CHK'D			
APPVD			

DWG NO.

SIDE TABLE 1

SCALE:1:20

SHEET 3 OF 3

A4