

REV/DATE	DESCRIPTION
00 / 19/04/2020	INITIAL REVISION

NOTES:

1. (⊥) ALL VERTICAL SUPPORTS ARE PERPENDICULAR.
2. □ FLATNESS OF .5MM IS APPLIED BY DEFAULT.
3. ∇ WELD BEAD OF 2MM RADIUS IS FOLLOWED.
4. ∇∇ SURFACE FINISH MEDIUM TO SMOOTH IS USED.
5. ALL TUBES ARE AS PER APL APOLLO STANDARD. CHANGES MAY EFFECT THE LOAD CAPACITY.
6. ALL HORIZONTAL AND VERTICAL TUBES ARE PERPENDICULAR TO EACH OTHER WITH ±1 DEG.
7. FINE WELDNG IS REQUIRED AS PER MENTIONED DETAILS AND FINISHING.
8. HIGHER CURRENT WELDING MAY AFFECT THE BRITTLENESS OF MATERIAL WHICH LATER MAY RAISE TO WEAKENING OF STRUCTURE.
9. FABRICATORS ARE ALLOWED TO USE FITTINGS/FRAMES/SUPPORTS AS NEEDED AND THE SAME MUST BE COMMUNICATED BACK TO ENGINEERING TEAM.
10. LENGTH OF ALL LONGITUDINAL FRAMES ARE FOR REFERENCE ONLY AND SUBJECTED TO CHANGE PER REQUIREMENT.

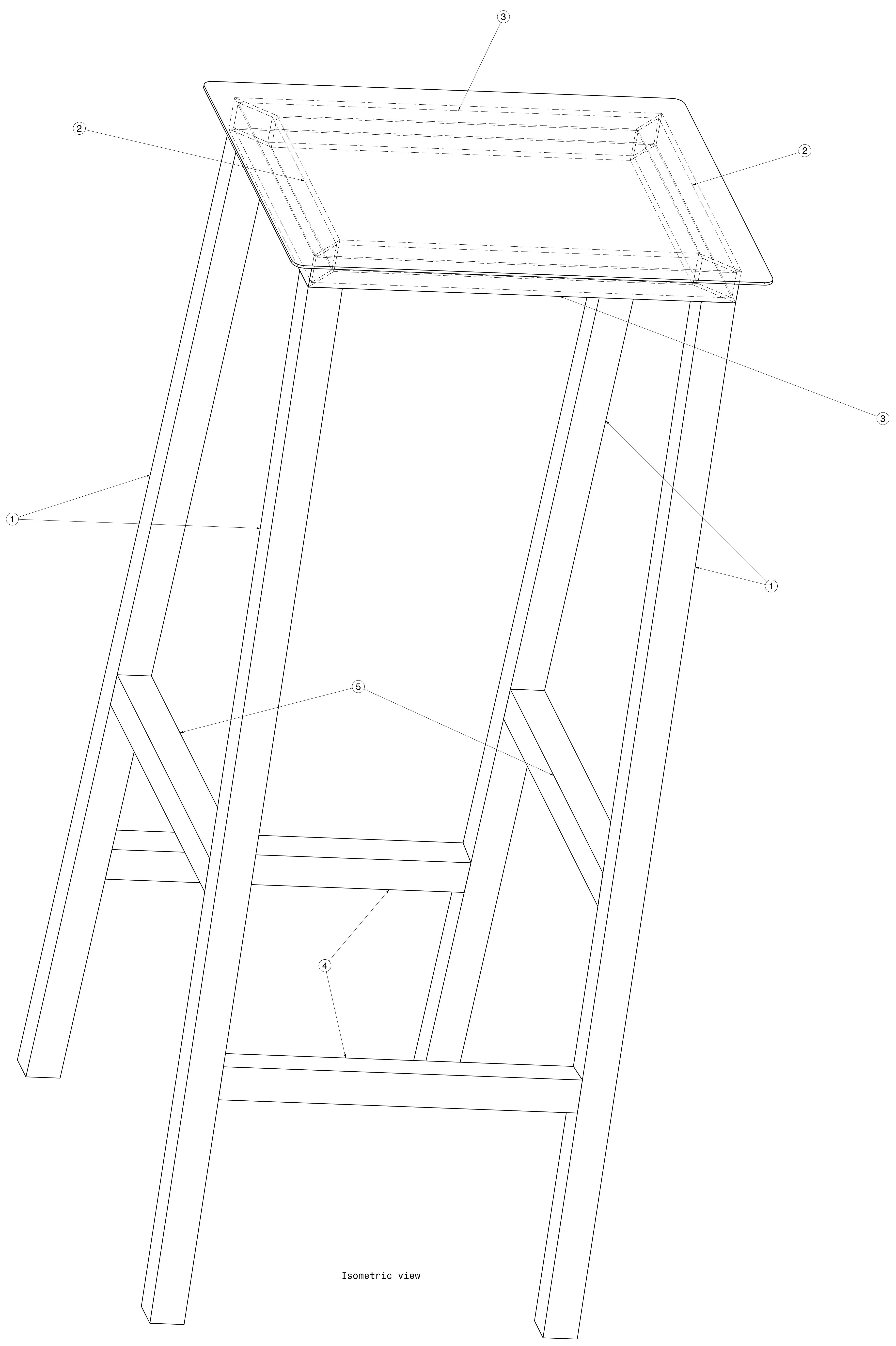

ITEM NO.	PART NUMBER	DESCRIPTION	QTY.	Wt (Kg) /Each
6	Plate -BOP	450 X 350, T=2.5	1	3.1
5	Sq Tube Chair Frame 5	32 X 32 X 3.2 X 356	2	1.1
4	Sq Tube Chair Frame 4	32 X 32 X 3.2 X 336	2	1
3	Rect Tube Chair Frame 3	32 X 32 X 3.2 X 400	2	1.2
2	Sq Tube Chair Frame 2	32 X 32 X 3.2 X 300	2	0.8
1	Sq Tube Chair Frame 1	32 X 32 X 3.2 X 1008	4	2.9

This drawing is our property. It can't be reproduced or communicated without our written agreement.

APL APOLLO TUBES LTD.

DRAWING TITLE
STOOL

<table border="1" style="width: 100%;"> <tr> <td>DRAWN BY</td> <td>DATE</td> </tr> <tr> <td>SB</td> <td>19/04/2020</td> </tr> </table>	DRAWN BY	DATE	SB	19/04/2020	<table border="1" style="width: 100%;"> <tr> <td>CHECKED BY</td> <td>DATE</td> </tr> <tr> <td>P2P Analysis & Solutions</td> <td>19/04/2020</td> </tr> </table>	CHECKED BY	DATE	P2P Analysis & Solutions	19/04/2020	<table border="1" style="width: 100%;"> <tr> <td>SIZE</td> <td>DRAWING NUMBER</td> <td>REV</td> </tr> <tr> <td>A0</td> <td>P2P_STOOL</td> <td>00</td> </tr> </table>	SIZE	DRAWING NUMBER	REV	A0	P2P_STOOL	00
DRAWN BY	DATE															
SB	19/04/2020															
CHECKED BY	DATE															
P2P Analysis & Solutions	19/04/2020															
SIZE	DRAWING NUMBER	REV														
A0	P2P_STOOL	00														
<table border="1" style="width: 100%;"> <tr> <td>DESIGNED BY</td> <td>DATE</td> </tr> <tr> <td>P2P Analysis & Solutions</td> <td>19/04/2020</td> </tr> </table>	DESIGNED BY	DATE	P2P Analysis & Solutions	19/04/2020	<table border="1" style="width: 100%;"> <tr> <td>SCALE</td> <td>WEIGHT (kg)</td> <td>Okg</td> </tr> <tr> <td>As Indicated</td> <td></td> <td></td> </tr> </table>	SCALE	WEIGHT (kg)	Okg	As Indicated			<table border="1" style="width: 100%;"> <tr> <td>SHEET 1 OF 5</td> </tr> </table>	SHEET 1 OF 5			
DESIGNED BY	DATE															
P2P Analysis & Solutions	19/04/2020															
SCALE	WEIGHT (kg)	Okg														
As Indicated																
SHEET 1 OF 5																

UNLESS OTHERWISE SPECIFIED DIMENSION ARE IN MM
VIEWS: THIRD ANGLE PROJECTION

REV	DATE	DESCRIPTION
00	19/04/2020	INITIAL REVISION

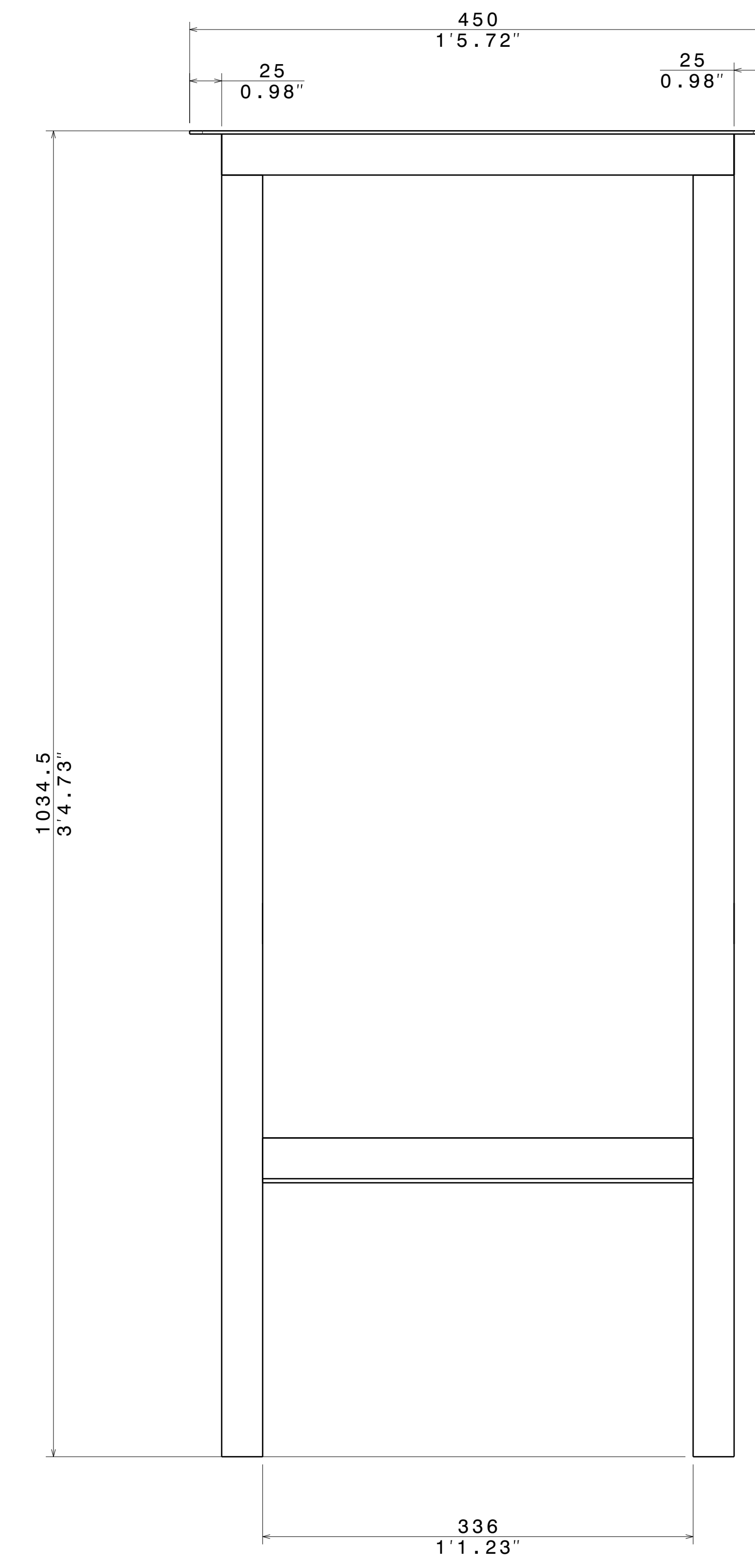
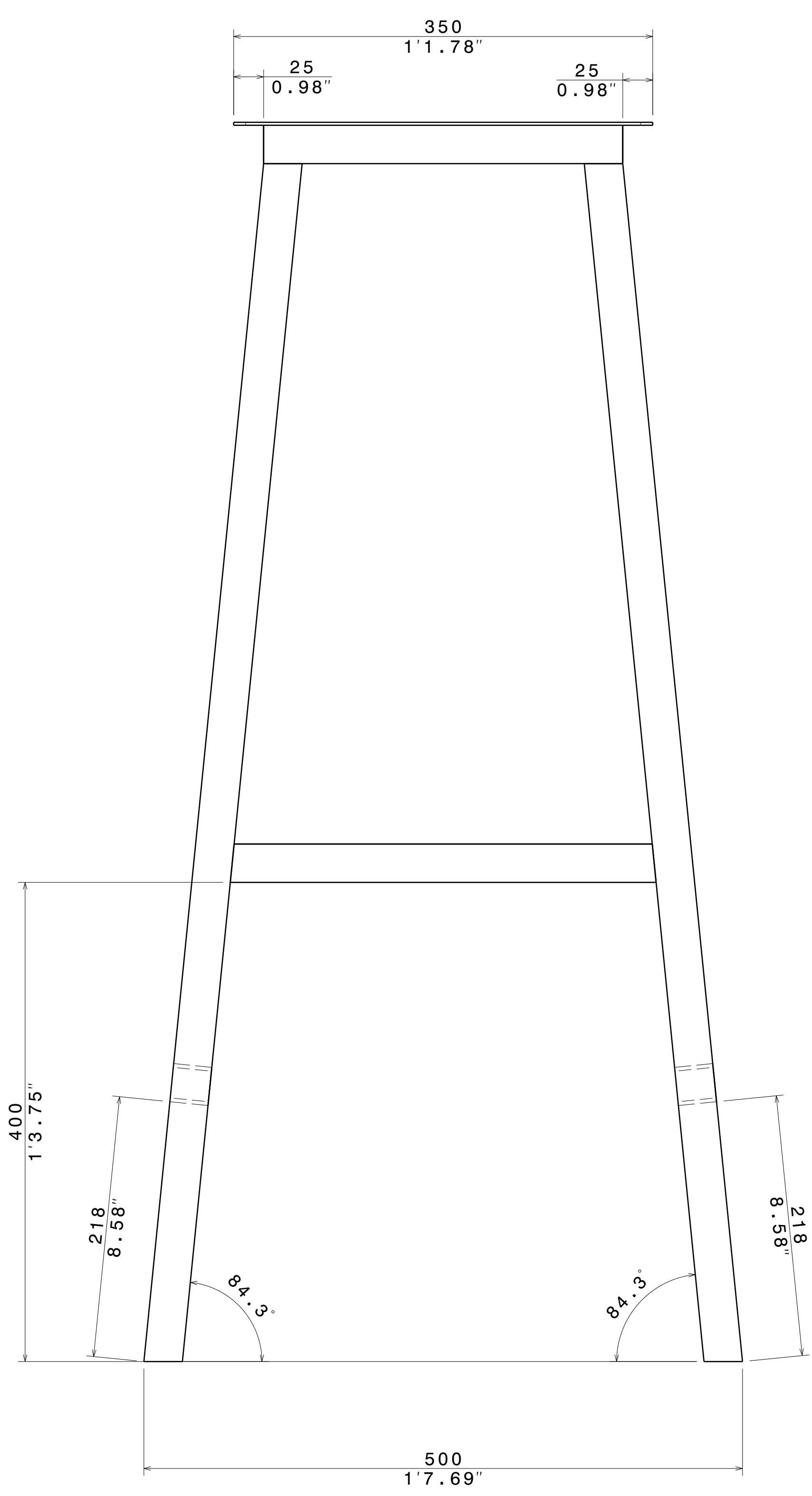
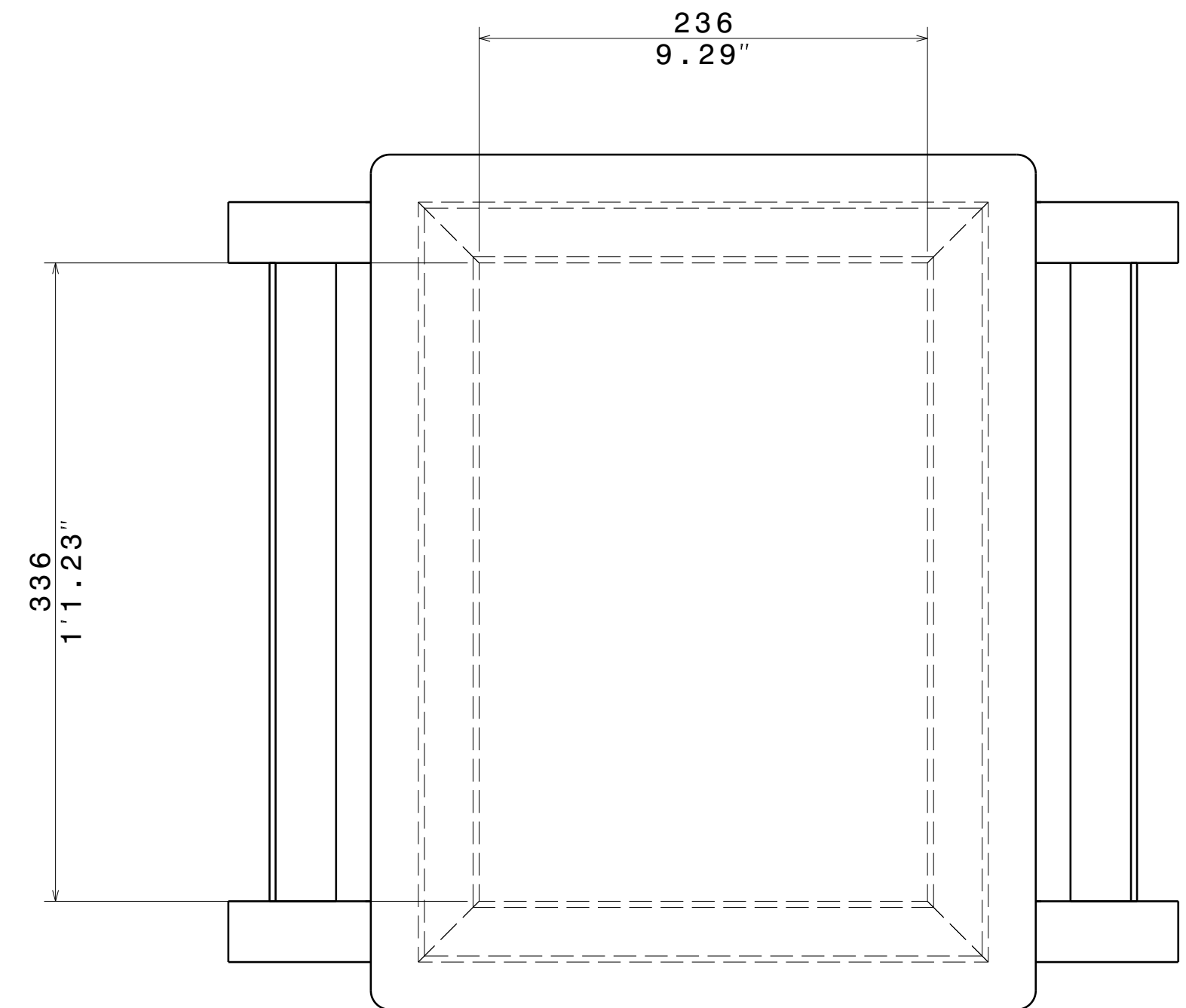

UNLESS OTHERWISE SPECIFIED DIMENSION ARE IN MM
 VIEWS: THIRD ANGLE PROJECTION

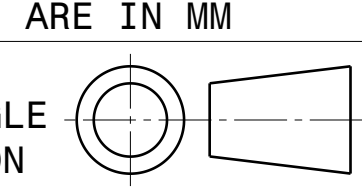

This drawing is our property. It can't be reproduced or communicated without our written agreement.		APL APOLLO TUBES LTD. 	
DRAWN BY SB		DATE 19/04/2020	
CHECKED BY P2P Analysis & Solutions		DATE 19/04/2020	
DESIGNED BY P2P Analysis & Solutions		DATE 19/04/2020	
SIZE A0	DRAWING NUMBER P2P_STOOL	REV 00	
SCALE NONE	WEIGHT (kg) XXX	SHEET 2 OF 5	

REV	DATE	DESCRIPTION
00	19/04/2020	INITIAL REVISION

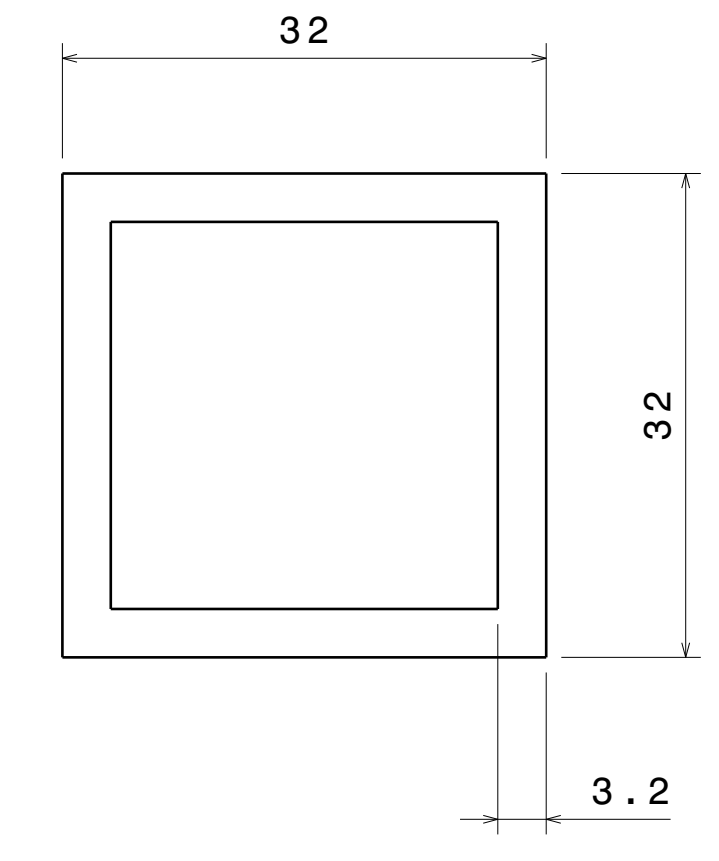

Section Detail of ITEM 1,2,3,4 & 5
Scale: 2:1

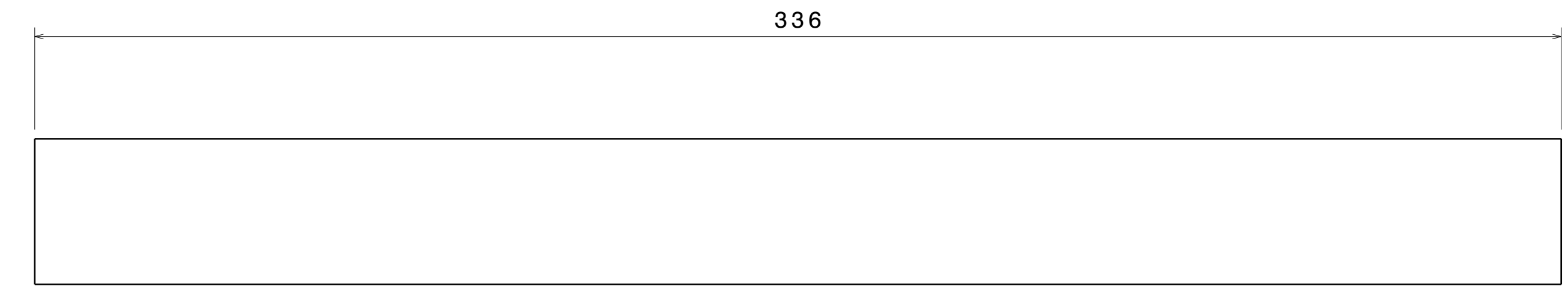

ITEM 4 DETAILS
Sq Tube Stool Frame 4

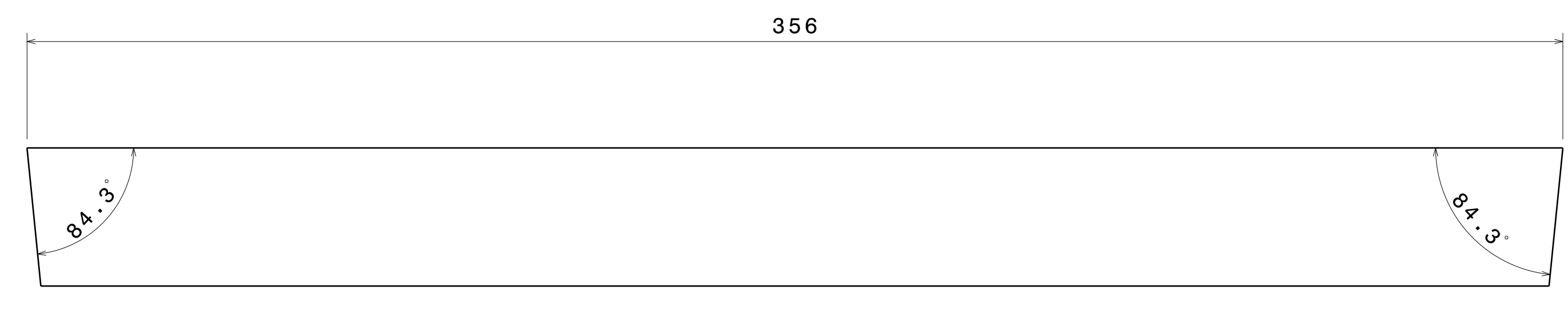

ITEM 5 DETAILS
Sq Tube Stool Frame 5

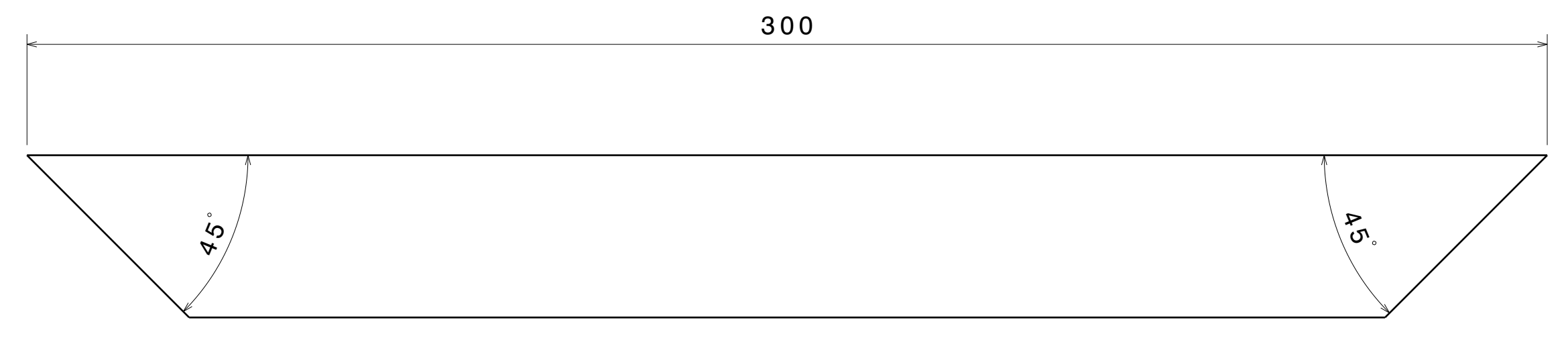

ITEM 2 DETAILS
Sq Tube Stool Frame 2

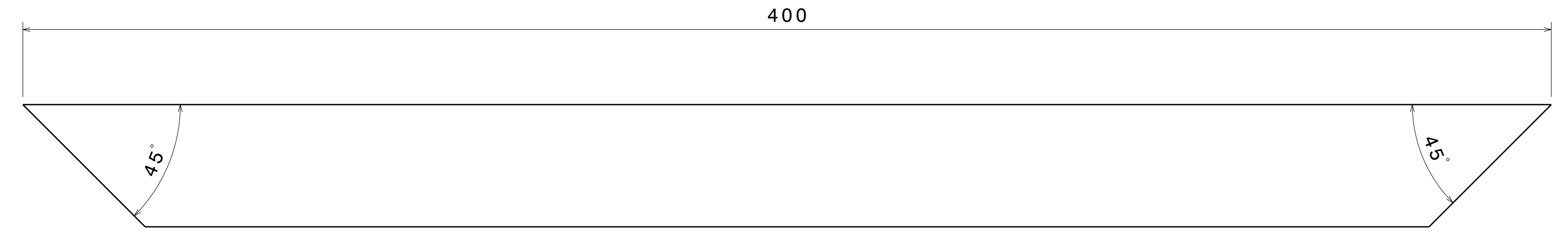

ITEM 3 DETAILS
Sq Tube Stool Frame 3

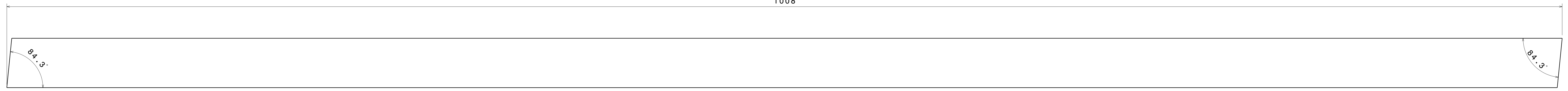

ITEM 1 DETAILS
Sq Tube Stool Frame 1

UNLESS OTHERWISE SPECIFIED DIMENSION ARE IN MM
VIEWS: THIRD ANGLE PROJECTION

This drawing is our property. It can't be reproduced or communicated without our written agreement.

DRAWN BY	DATE
SB	19/04/2020
CHECKED BY	DATE
P2P Analysis & Solutions	19/04/2020
DESIGNED BY	DATE
P2P Analysis & Solutions	19/04/2020

APL APOLLO TUBES LTD.	
DRAWING TITLE	
STOOL	
SIZE	DRAWING NUMBER
A0	P2P_STOOL
SCALE	WEIGHT (kg)
NONE	XXX
REV	SHEET 3 OF 5
00	