			DO NOT SCALE DRAWING		REVISION
			TITLE:		
	NAME	SIGNATURE	DATE	DWG NO. TABLE 1	
DRAWN					
CHK'D					
APPVD				SCALE:1:20	SHEET 1 OF 3

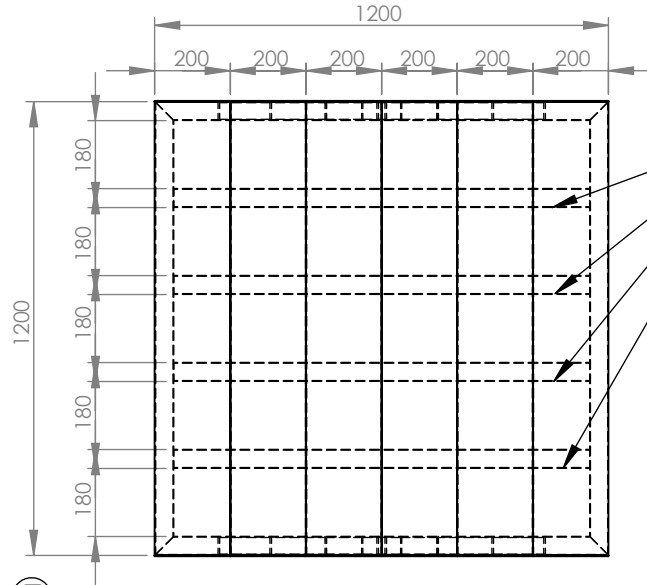

NOTE :-

- ALL VERTICAL AND HORIZONTAL SUPPORTS ARE PERFECTLY 90°.
- ∇∇ SURFACE FINISH, MEDIUM TO SMOOTH IS USED.
- ALL TUBES ARE AS PER APL APOLLO STANDARD.
- FINE WELDING IS REQUIRED AS PER MENTION DETAILS AND FINISHING.
- JOINTS ARE WELD TOGETHER BY THE HIGH ACCURACY MIG WELDING.
- ALL DIMENSIONS ARE IN MM.
- HIGHER CURRENT WELDING MAY EFFECT THE BRITTLENESS OF MATERIAL WHICH MAY RAISE TO WEAKENING OF STRUCTURE.

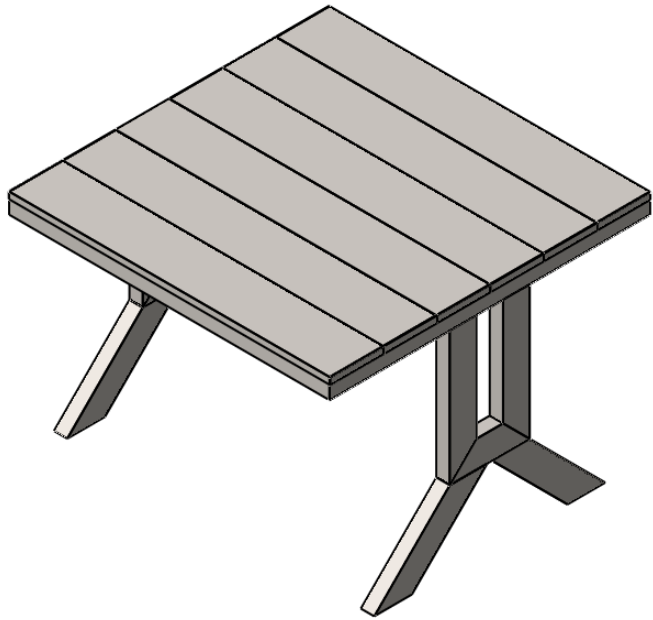
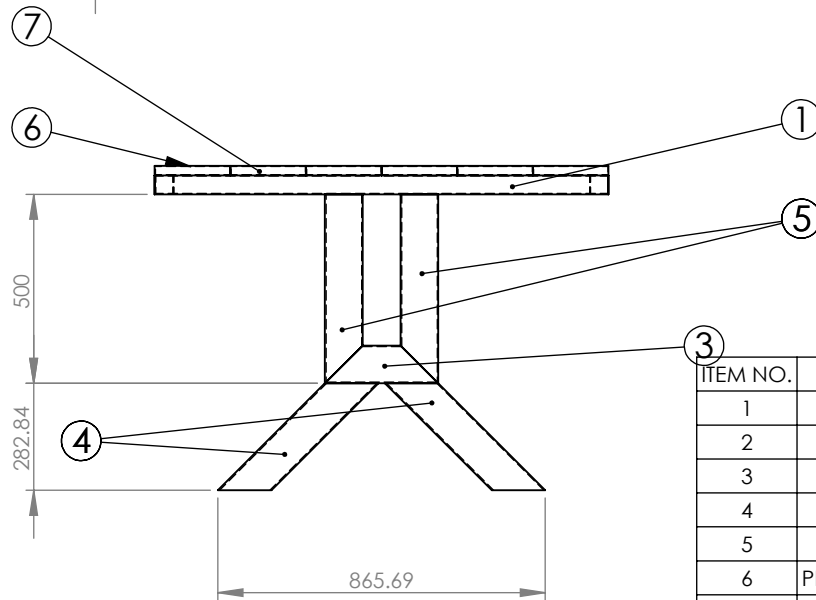
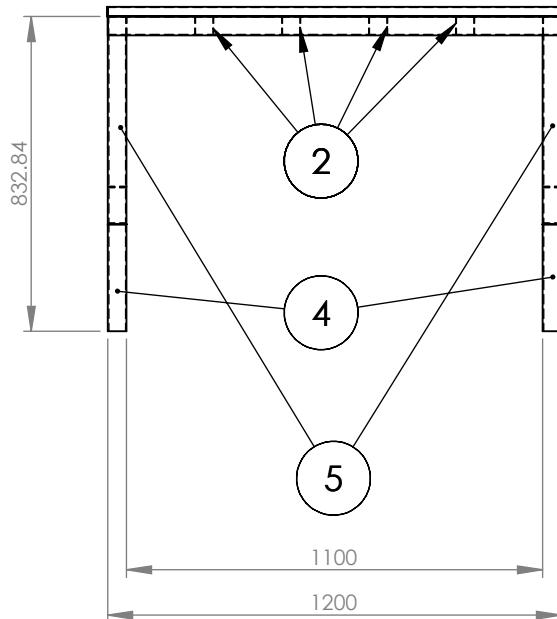

ITEM NO.	PART NUMBER	DESCRIPTION	QTY.	Unit
1	50X50X2X1200	SHS	4	4800
2	50X50X2X1100	SHS	4	4400
3	100X50X3X300	RHS	2	600
4	100X50X3X500 (2)	RHS	4	2000
5	100X50X3X500	RHS	4	2000
6	PLANK 200X25X1.6X1200	PLANK	6	7200
7	PLATE 200X25X2.0	PLATE	12	



DO NOT SCALE DRAWING

REVISION

TITLE:

	NAME	SIGNATURE	DATE
DRAWN			
CHK'D			
APPVD			

DWG NO.

TABLE 1

SCALE:1:20

SHEET 2 OF 3

A4

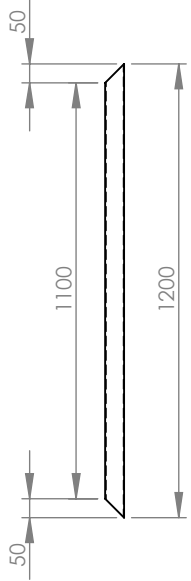

ITEM 1
SHS 50X50X2.0X1200

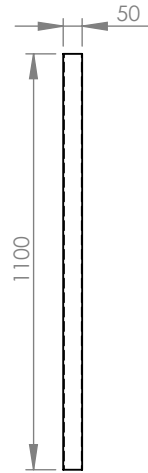

ITEM 2
SHS 50X50X2.0X1100

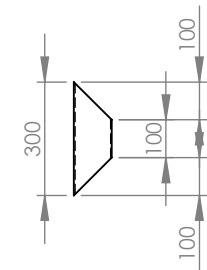

ITEM 3
RHS 100X50X3.0X300

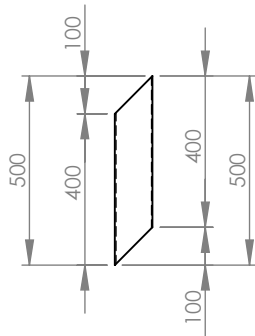

ITEM 4
RHS 100X50X3.0X500 (2)

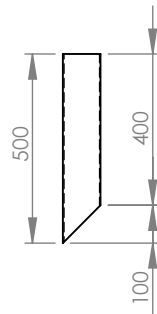

ITEM 5
RHS 100X50X3.0X500

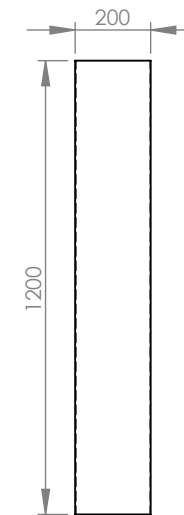

ITEM 6
PLANK 200X25X1.6X1200

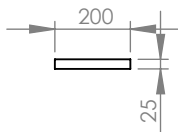

ITEM 7
PLATE 200X25X2.0



DO NOT SCALE DRAWING

REVISION

TITLE:

PART DRAWINGS

	NAME	SIGNATURE	DATE
DRAWN			
CHK'D			
APPV'D			

DWG NO.

TABLE 1

SCALE:1:20

SHEET 3 OF 3

A4